

MODULAR BELTS AND CHAINS



MODUTECH[®]
Movement Technologies





INTRODUCTION

4 - 5

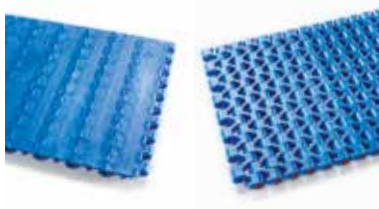

STRAIGHT MODULAR BELTS

7 ÷ 79

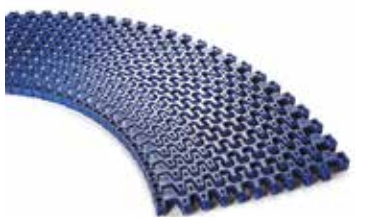

CURVED MODULAR BELTS

81 ÷ 93

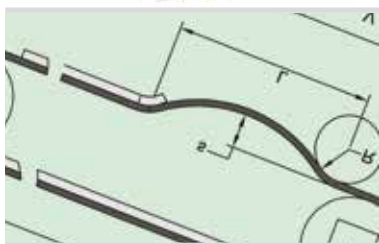

TECHNICAL FEATURES

95 ÷ 98

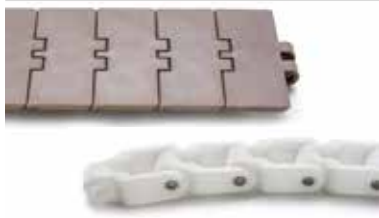

STRAIGHT MODULAR CHAINS

99 ÷ 106



CURVED MODULAR CHAINS

107 ÷ 112



CLAMP FOR SPROCKETS

113 - 114

MODULAR BELTS AND CHAINS

The background of the page is a collage of images related to modular belts and chains. At the top, there is a close-up of a blue, diamond-shaped mesh. Below this, a large section shows a blue and white interlocking modular belt pattern. At the bottom, there is a close-up of a white plastic chain link with a metal pin. The main title is overlaid on a semi-transparent white rectangular area in the center.

Modular belts and chains

INDEX

MODULAR BELTS AND CHAINS	PAGE
Belt choice	4-5
STRAIGHT MODULAR BELTS	
MP80 type	
NMMP80C	8
NMMP80NS	9
NMEMP80NP	10
NMMP80FG	11
Sprockets	12 - 13
G50 type	
NMMD127G50	14
Sprockets	15
EC127 type	
NMEC127C	16
NMEC127FG	17
NMEC127GT	18
Accessories and sprockets	19 ÷ 21
EC254 type	
NMEC254C	22
NMEC254P16	23
NMEC254NT	24
Accessories and sprockets	25 ÷ 27
MD254 type	
NMMD254C	28
NMMD254FG	29
NMMD254G48	30
NMMD254GT	31
NMMD254RR	32
Accessories and sprockets	33 ÷ 35
XP254 type	
NMXP254FG	36
NMXP254P22	37
NMXP254C	38
NMXP254CL	39
NMXP254CR	40
Accessories and sprockets	41 - 43
HP254 type	
NMHP254C	44
NMHP254P22	45
NMHP254GT	46
NMHP254RR	47
Accessories and sprockets	48 ÷ 50
EC381 type	
NMEC381C	51
NMEC381P22	52
NMEC381FG	53
NMEC381NT	54
Accessories and sprockets	55 ÷ 57



EC508 type	
NMEC508C	58
NMEC508P11	59
NMEC508P13	60
NMEC508P22	61
NMEC508FG	62
NMEC508DT	63
NMEC508NT	64
NMEC508FT	65
Accessories and sprockets	66 ÷ 68
MD508 type	
NMMD508C	69
NMMD508P25	70
NMMD508FG	71
Accessories and sprockets	72 ÷ 74
HP508 type	
NMHP508C	75
NMHP508FG	76
NMHP508RR	77
Accessories and sprockets	78 ÷ 79
CURVED MODULAR BELTS	
EC254R type	
NREC254R	82
HOLD DOWN and TAB for NREC254R	83
NREC254RT	84
Sprockets	85 - 86
EC254TR type	
NREC254TR	87
TAB EXT for NREC254TR	88
Sprockets	89 - 90
EC508S type	
NREC508S	91
Accessories and sprockets	92 - 93
TECHNICAL FEATURES	
Technical features of straight and curved belts	95 ÷ 98
STRAIGHT MODULAR CHAINS	
NCMD820	100
NCMD821	101
NCEC127C	102
NCEC127FG	103
NCMD254C	104
NCMD254FG	105
NCMD600-S / NCMDTAB-S	106
CURVED MODULAR CHAINS	
NCMD880 / NCMD879	108
NCMD880TAB / NCMD879TAB	109
NCMD1701-R	110
NCMD1701TAB-R	111
FLEXI	112
CLAMP FOR SPROCKETS	113 - 114



Modular belt

Belt choice

The choice of the modular belt is determined by combining the different versions available with the logistical needs and features of the object to be carried. Below are the main aspects that can guide your choice.

Length and shape of the path

The first distinction is between straight or curvilinear path.

The curved belt is one that allows a curved path.

Depending on the width and pattern, each belt allows a different radius.

Curves can be in both directions and / or form spirals in height. Curved belt can also be used as straight belts.

A small pitch allows faster speeds, less polygonal effect, and tight transfers.

A large pitch allows longer length, greater load capacity, and greater shock resistance.

Belt surface

The different belt surfaces meet the needs of various processes to be performed on the objects carried. The surfaces can be solid or permeable according to the need: washing, cooling, venting, or release of impurities from the product.

During the conveying, it is possible to heat or cool the product. It is possible to minimize the contact surface of the product on the belt for processes such as sterilization, pasteurization or drying.

Belts with different patterns are available to facilitate product release or transfer over sprockets that engage the surface ribs.

The belt can offer low friction to allow product to accumulate, or high friction for sloping elevation.

You can combine different designs on the same belt to achieve specific goals during transport.

Need for washing or load capacity

In food application it is necessary that the belt does not trap or allow stagnation of any material. The belts that have this feature are called Easy Clean "EC".

These belts are made of material that comply with the FDA and EU rules for food contact.

Belts with higher load and traction capacity are defined as High Power "HP".

Environmental Conditions

It is important to choose the correct material of the belt and pins to operate in the various possible environmental conditions.

Among these the most critical are:

- temperature
- presence of water or steam
- exposure to chemical agents
- contact with abrasive materials
- potential of bumps or shocks in the system

Standard material

PP - Polypropylene: thermoplastic material used for most common transportation applications with good cost/performance ratio and excellent chemical resistance to acids and alkalis. Operation at temperature below 10 °C must be observed.

Operating temperature: +5 °C to + 90 °C

PE - Polyethylene: thermoplastic material suitable for very low temperatures and/or high impact applications.

Excellent chemical resistance to acids and alkalis. Not suitable for abrasive applications. For temperatures below -40 °C, the compressive shrinking of the belt requires an adjustment of the pitch diameter of the sprockets.

Operating temperature: -70 °C to +65 °C

POM - Acetal Resin: high strength thermoplastic material and low coefficient of friction. Resistant to impacts and surface resistant to cutting. Suitable for heavy application and/or low temperature. Good chemical resistance to oils and alkalis, but not suitable for prolonged contact with high concentration of acids and chlorine.

Operating temperature: Dry conditions from -40 °C to +90 °C

Wet conditions from -40 °C to +60 °C

Special materials

POM-LF - Low friction acetal resin: high resistance thermoplastic material with very low coefficient of friction. High resistance to impact and surface resistant to cutting. Suitable for applications with high speeds and the need for excellent abrasion resistance.

Operating temperature: Dry conditions from -20 °C to +90 °C
Wet conditions from -20 °C to +60 °C

PPH - Polypropylene suitable for steam: stabilized thermoplastic material with improved resistance to oxidation and brittleness. Suitable for sterilization and pasteurization processes.

Operating temperature: Wet conditions from +5 °C to +105 °C

PA6.6 - Nylon 6.6: thermoplastic material with high mechanical and abrasion resistance. Suitable for heavy duty applications.

Dry conditions and high temperatures. The material is modified to maintain stable properties for extended exposure to high temperatures.

Operating temperature: Dry conditions from -40 °C to + 115 °C
Not recommended for wet conditions

PPA - Polypropylene Antistatic: thermoplastic material with antistatic properties in order to reduce accumulation of dust and electrical charges on the surface.

Operating temperature: from +5 °C to +80 °C

PPD - Detectable polypropylene: thermoplastic material with a special additive that makes the material detectable by X-ray and metal detectors. Excellent chemical resistance to alkali.

Operating temperature: from +5 °C to +80 °C

POMA - POM antistatic: thermoplastic material with reduced surface electrical resistance in order to reduce accumulation of dust and electrical charges on the surface.

Operating temperature: Dry conditions from -30 °C to +70 °C
Not recommended for wet conditions.

POMD - POM detectable: thermoplastic material with a special additive that makes the material detectable by X-ray and metal detectors.

Operating temperature: Dry conditions from -40 °C to +90 °C
Wet conditions from -40 °C to +60 °C

Suitable operating conditions for different belt/pin material combinations

		Temperature [°C]	Belt material	Pin material
Generic use	Dry conditions	-70 ÷ +60	PE	PE
		-40 ÷ +90	POM	PA
		+5 ÷ +90	PP	POM
	Wet conditions	-70 ÷ +60	PE	POM / PE
		-40 ÷ +90	POM	POM / PP
		+5 ÷ +90	PP	POM / PP
		+10 ÷ +105	PPH	PPH
High loads	Dry conditions	Room temperature	POM	PA
	Wet conditions	Room temperature	POM	POM / PP
High chemical resistance	-	Room temperature	PP	PP
Need of abrasion resistance	Dry conditions	Up to a 60	POM	PA
	Wet conditions	Up to a 60	PP	PP
	Wet conditions and high loads	Up to a 60	POM	POM

STRAIGHT MODULAR BELTS

The background of the page is a collage of images showing different types of modular belts. At the top, there is a blue belt with a grid-like structure. Below it is a grey belt with a similar grid pattern. In the center, there is a white belt with a grid pattern and small circular indentations. At the bottom, there are black and grey belts with a grid pattern and small circular indentations. The text 'Straight Modular belts' is overlaid on the white belt in a large, bold, green font.

**Straight Modular
belts**

PITCH 8 mm / 0,3"

Belt type: closed flat top surface
Pin diameter: \varnothing 3 mm
Open area: 0%
Hole openings: -
Minimum width: 101,6 mm
Nose bar diameter: 6 mm
Thickness: 6 mm
Accessories: -
Food Certification: FDA - EU

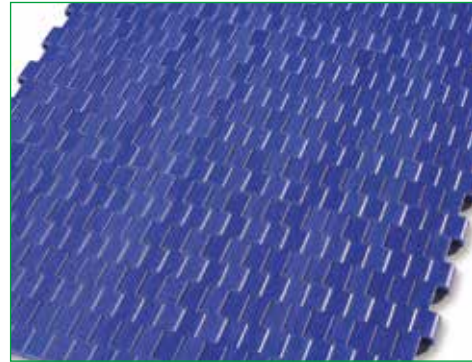

Standard executions

Belt material	Belt color	Pin
POM	White - blue	POM

Other materials and colors are available upon request.

Belt material	Pin material	Belt performance [N/m]	Temperature range [°C]	Certification	Weight [kg/m ²]
POM	PA	2550	-43 ÷ +80	FDA - EU	1,08

PP = Polypropylene - PE = Polyethylene - POM = Acetal Resin - PA = Polyamide

Belt width [W]

Minimum [mm]	Standard increment [mm]	Special increment [mm]	Width tolerance* [mm]
101,6	Multiple: 152,4	Multiple: 25,4	+/-2 up to 300
			+/-3 up to 600
			+/-4 more than 600

*It is advisable to consider dimensional variations in width based on operating temperatures and humidity when the belt is made of polyamide.

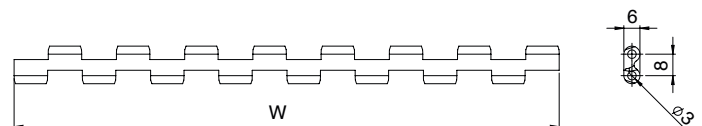
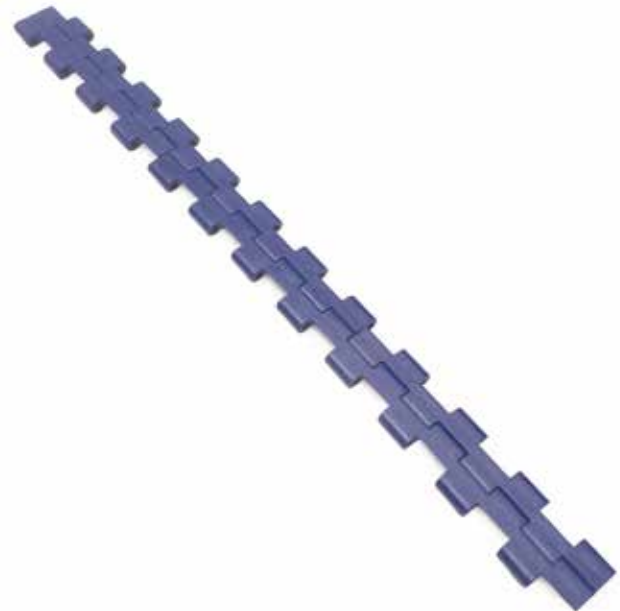

Part number	NMMP 80 C -PO -B	
Type	Belt color: W = white / B = blue	
Pitch	Belt material: PO = POM - Acetal Resin / PA = Polyamide	
Closed flat top surface		

NMMP80NS

PITCH 8 mm / 0,3"

STRAIGHT MODULAR BELTS

Belt type: no slip closed surface with diamond pattern

Pin diameter: Ø 3 mm

Open area: 0%

Hole openings: -

Minimum width: 101,6 mm

Nose bar diameter: 6 mm

Thickness: 6 mm

Accessories: -

Food Certification: FDA - EU

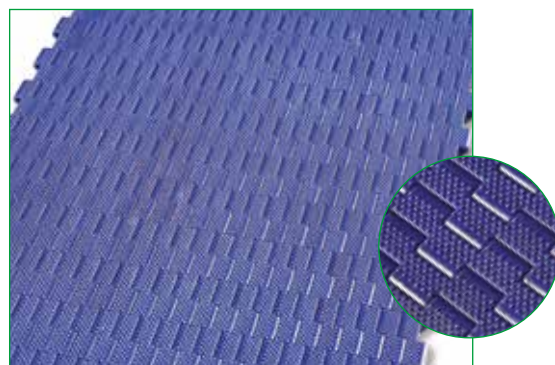

Standard executions

Belt material	Belt color	Pin
POM	White - blue	POM

Other materials and colors are available upon request.

Belt material	Pin material	Belt performance [N/m]	Temperature range [°C]	Certification	Weight [kg/m²]
POM	PA	2550	-43 ÷ +80	FDA - EU	1,08

PP = Polypropylene - PE = Polyethylene - POM = Acetal Resin - PA = Polyamide

Belt width [W]

Minimum [mm]	Standard increment [mm]	Special increment [mm]	Width tolerance* [mm]
101,6	Multiple: 152,4	Multiple: 25,4	+/-2 up to 300
			+/-3 up to 600
			+/-4 more than 600

*It is advisable to consider dimensional variations in width based on operating temperatures and humidity when the belt is made of polyamide.

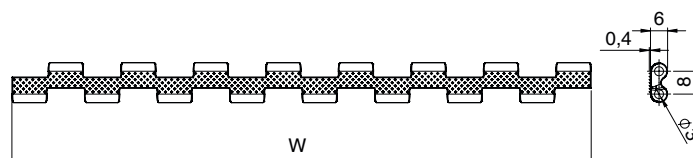
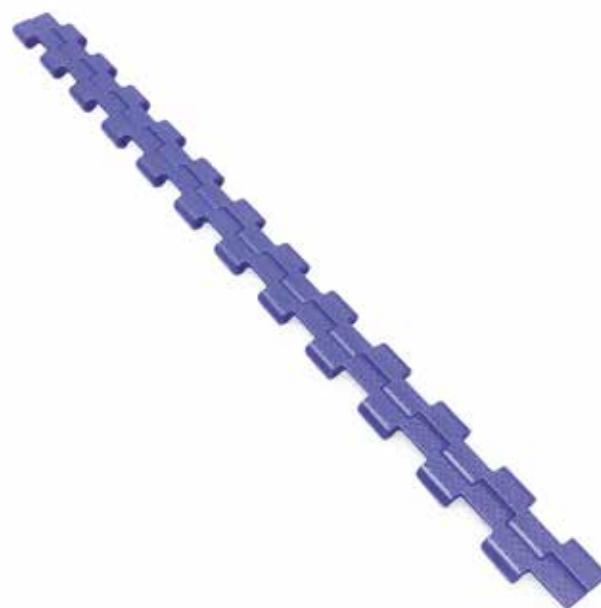

Part number

NMMP 80 NS -PO -B

Type

Pitch

No slip closed surface with diamond pattern

Belt color: W = white / B = blue

Belt material:
PO = POM - Acetal Resin / PA = Polyamide

PITCH 8 mm / 0,3"

Belt type: no cling closed surface, inverted diamond pattern

Pin diameter: Ø 3 mm

Open area: 0%

Hole openings: -

Minimum width: 101,6 mm

Nose bar diameter: 6 mm

Thickness: 6 mm

Accessories: -

Food Certification: FDA - EU

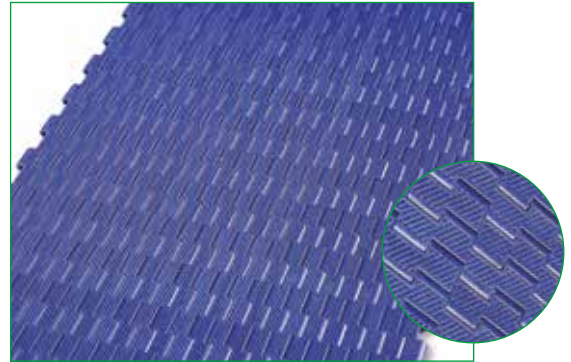

Standard executions

Belt material	Belt color	Pin
POM	White - blue	POM

Other materials and colors are available upon request.

Belt material	Pin material	Belt performance [N/m]	Temperature range [°C]	Certification	Weight [kg/m ²]
POM	PA	2550	-43 ÷ +80	FDA - EU	1,08

PP = Polypropylene - PE = Polyethylene - POM = Acetal Resin - PA = Polyamide

Belt width [W]

Minimum [mm]	Standard increment [mm]	Special increment [mm]	Width tolerance* [mm]
101,6	Multiple: 152,4	Multiple: 25,4	+/-2 up to 300
			+/-3 up to 600
			+/-4 more than 600

*It is advisable to consider dimensional variations in width based on operating temperatures and humidity when the belt is made of polyamide.

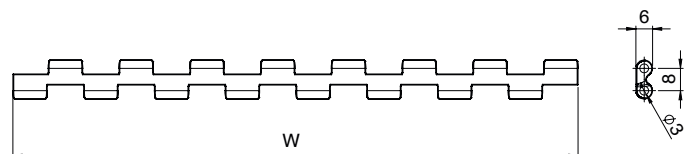
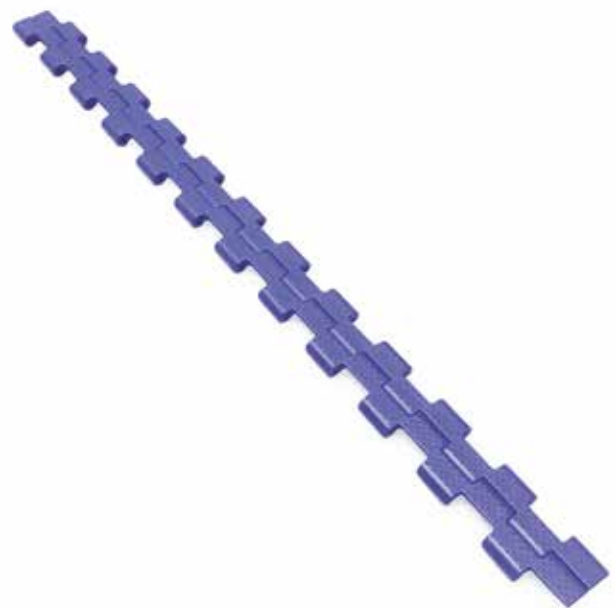

Part number	NMMP 80	NP -PO	NP
Type			
Pitch			
No cling closed surface, inverted diamond pattern			
	Belt color: W = white / B = blue		
	Belt material: PO = POM - Acetal Resin / PA = Polyamide		

NMMP80FG

PITCH 8 mm / 0,3"

STRAIGHT MODULAR BELTS

Belt type: open flat surface flush grid

Pin diameter: Ø 3 mm

Open area: 40%

Hole openings: 9x3 mm

Minimum width: 101,6 mm

Nose bar diameter: 6 mm

Thickness: 6 mm

Accessories: -

Food Certification: FDA - EU

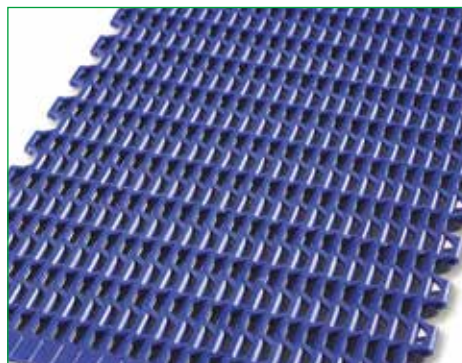

Standard executions

Belt material	Belt color	Pin
POM	White - blue	POM

Other materials and colors are available upon request.

Belt material	Pin material	Belt performance [N/m]	Temperature range [°C]	Certification	Weight [kg/m ²]
POM	PA	2550	-43 ÷ +80	FDA - EU	0,8

PP = Polypropylene - PE = Polyethylene - POM = Acetal Resin - PA = Polyamide

Belt width [W]

Minimum [mm]	Standard increment [mm]	Special increment [mm]	Width tolerance* [mm]
101,6	Multiple: 152,4	Multiple: 25,4	+/-2 up to 300
			+/-3 up to 600
			+/-4 more than 600

**It is advisable to consider dimensional variations in width based on operating temperatures and humidity when the belt is made of polyamide.*

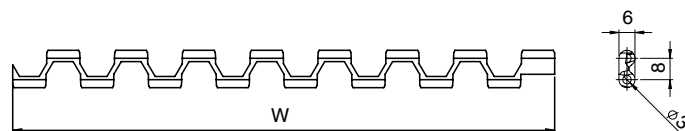
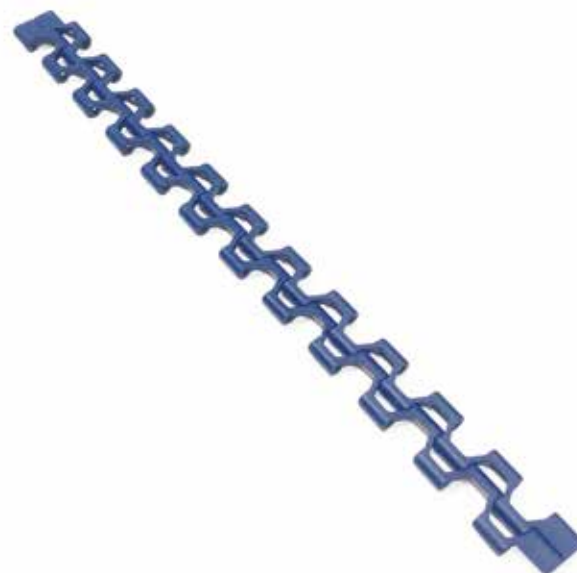

Part number

NMMP 80 FG -PO -B

Type _____
 Pitch _____
 Open flat surface flush grid

Belt color: W = white / B = blue
 Belt material:
 PO = POM - Acetal Resin / PA = Polyamide

Sprockets for MP80 type



Teeth nr.	Dp [mm]	Do [mm]	A [mm]	B [mm]	Available standard bore	
					Square [mm]	Ø round + set-screw UNI
18	46,5	47,7	20	6	20x20	20 - 25
24	61,8	63,3	20	6	25x25	20 - 25 - 30
36	92,6	94,5	20	6	40x40	25 - 30

Standard material: nylon PA6 fiberglass.
 It is possible to supply sprocket with any number of teeth or any material by CNC machining
 Dp = Pitch diameter
 Do = External tooth diameter

Part number NSMP80 -Q 25 -Z24

Type _____

Bore type: R = round / Q = square _____

Bore dimension (mm) _____

Teeth nr. _____

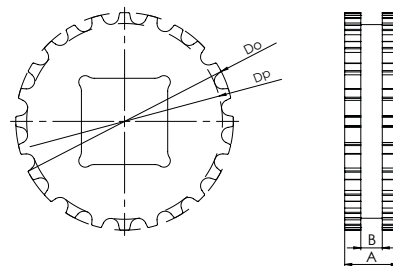

Belt width [mm]			101,6	203,2	304,8	406,4	508	609,6	711,2	812,8	914,4	1016	1117,6	1219,2	1320,8
Number of sprockes	Drive shaft	Minimum number of sprockets	2	3	4	4	5	6	8	9	10	11	13	15	17
	Driven shaft		2	2	3	3	4	5	7	7	9	9	11	11	11
Sliding guides			2	2	3	3	4	5	5	6	6	7	7	8	8

Mounting

When mounting the sprockets, make sure that you have mounted all sprockets oriented in the same phase.
 Only axially lock the central sprocket and leave the other sprockets free to move axially

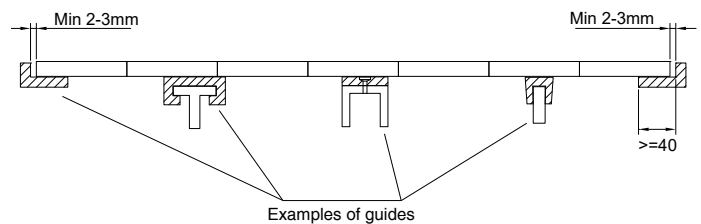

Sprockets for MP80 type

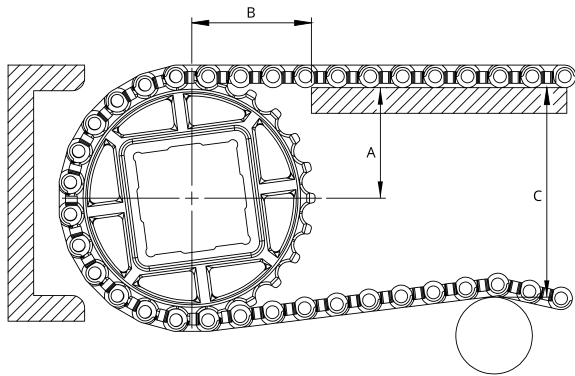

Z [mm]	A [mm]	B1 [mm]	B2 [mm]	C _{max} [mm]
18	20,2	28	12	40
24	27,9	35	12	50
36	43,3	50	12	80

In order to avoid any subsidence of the belt in the area between the guiding strip and the sprockets, it is possible to locate the guides between the sprockets. Two minimum B1 and B2 dimensions are defined.

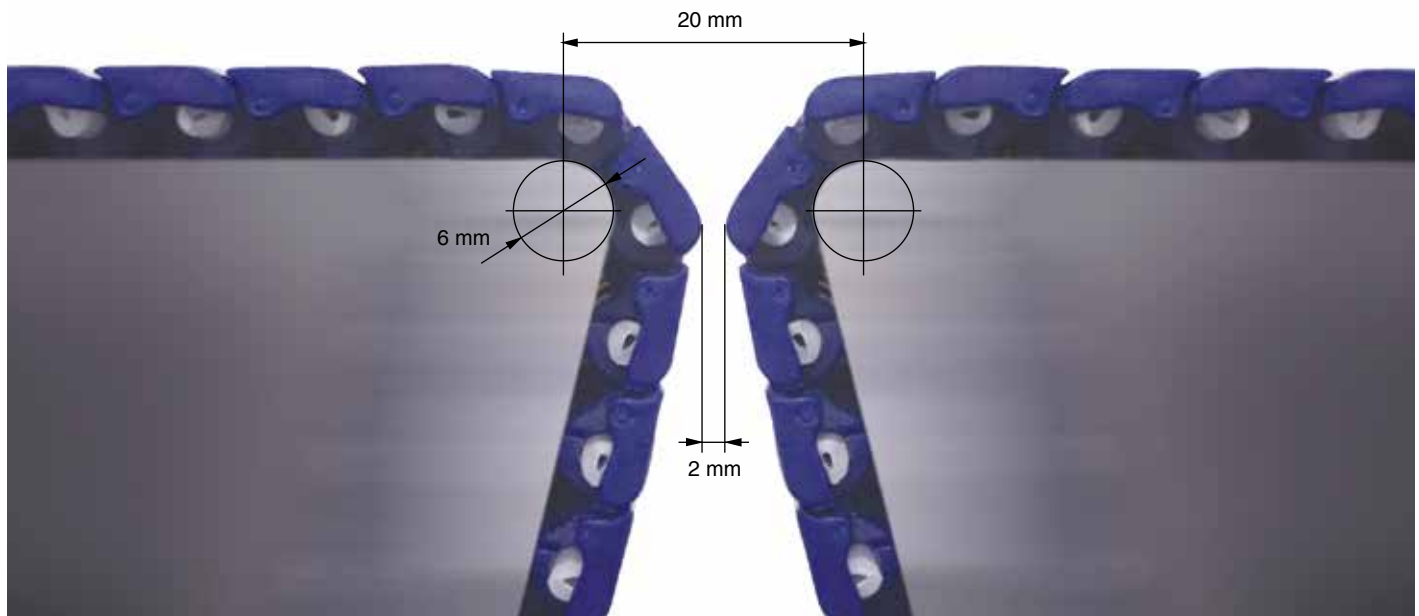
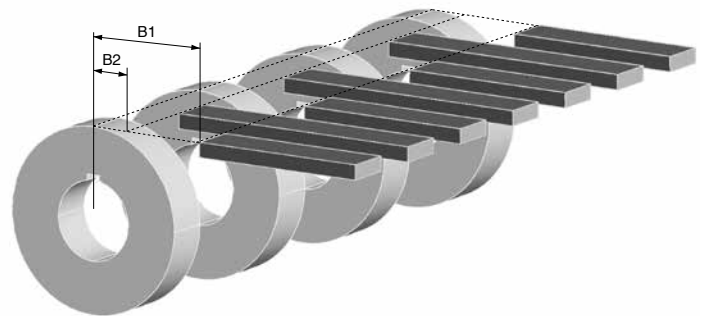

PITCH 12,7 mm / 0,5"

Belt type: open flat surface
Pin diameter: Ø 3,6 mm
Open area: 50%
Hole openings: 20x7 mm
Minimum width: 203 mm
Thickness: 7 mm
Nose bar diameter: 12,7 mm
Accessories: -
Food Certification: FDA - EU

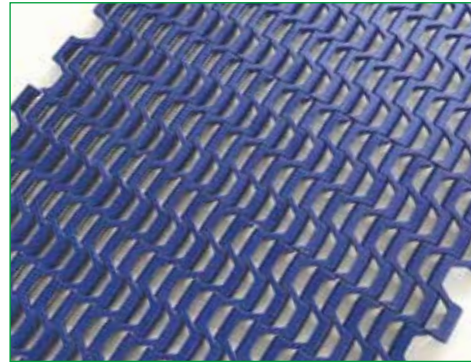

Standard executions

Belt material	Belt color	Pin
POM	Blue - white	PA - PP
PP	Blue - white	POM - PP

Other materials and colors are available upon request.

Belt material	Pin material	Belt performance [N/m]	Temperature range [°C]	Certification	Weight [kg/m²]
PP	PP	2700	+5 ÷ +70	FDA - EU	0,9
POM	PP	4200	+5 ÷ +70	FDA - EU	1,2
POM	PA	4500	-40 ÷ +70	FDA - EU	1,2

PP = Polypropylene - PE = Polyethylene - POM = Acetal Resin - PA = Polyamide

Belt width [W]

Minimum [mm]	Standard increment [mm]	Special increment [mm]	Width tolerance* [mm]
203	Multiple: 50,8	Multiple: 12,7	+/-2 up to 300
			+/-3 up to 600
			+/-4 more than 600

*It is advisable to consider dimensional variations in width based on operating temperatures and humidity when the belt is made of polyamide.

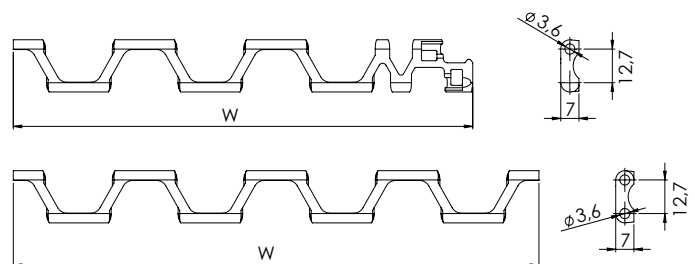
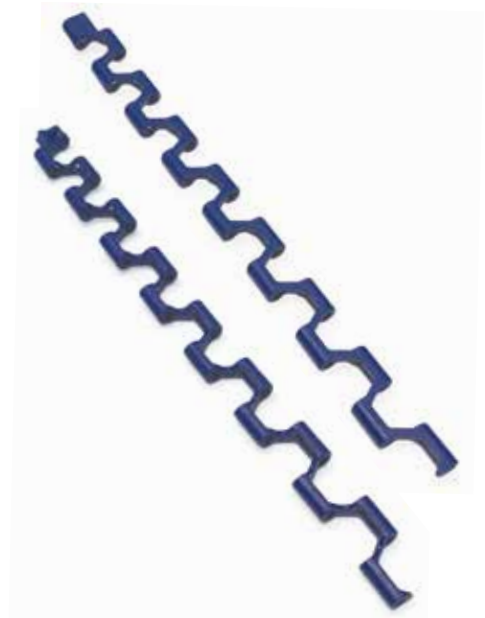

Part number	NMMD 127 G50 -PP -B	
Type		Belt color: B = blue / W = white
Pitch		Belt material: PO = POM - Acetal Resin / PP = Polypropylene PA = Polyamide
Open flat surface at 50%		

Sprockets for MD127G50 type



Teeth nr.	Dp [mm]	Do [mm]	A [mm]	B [mm]	Available standard bore	
					Square [mm]	Ø round + set-screw UNI
12	49,8	52,0	20	10	25x25	20 - 25
14	58,0	60,2	20	10	25x25	20 - 25
17	70,2	72,4	20	10	25x25	20 - 25
19	78,4	80,5	20	10	25x25	25 - 30
24	98,8	100,9	20	10	25x25 40x40	25 - 30
36	148,0	150,0	20	10	25x25 40x40	25 - 30

Standard material: delrin.
 It is possible to supply sprocket with any number of teeth or any material by CNC machining
 Dp = Pitch diameter
 Do = External tooth diameter

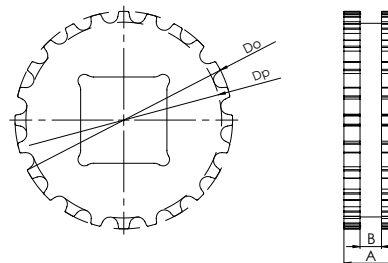

Part number NSMD127 -Q 25 -Z24

Type _____

Bore type: R = round / Q = square _____

Bore dimension (mm) _____

Teeth nr. _____

Belt width [mm]			101,6	203,2	304,8	406,4	508	609,6	711,2	812,8	914,4	1016	1117,6	1219,2	1320,8
Number of sprockes	Drive shaft	Minimum number of sprockets	2	3	4	4	5	6	8	9	10	11	13	15	17
	Driven shaft		2	2	3	3	4	5	7	7	9	9	11	11	11
Sliding guides			2	2	3	3	4	5	5	6	6	7	7	8	8

Mounting

When mounting the sprockets, make sure that you have mounted all sprockets oriented in the same phase.
 Only axially lock the central sprocket and leave the other sprockets free to move axially.

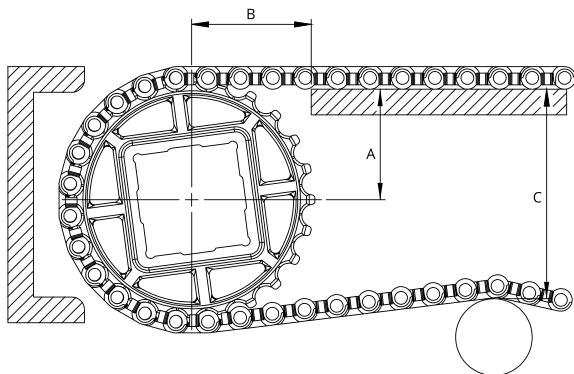
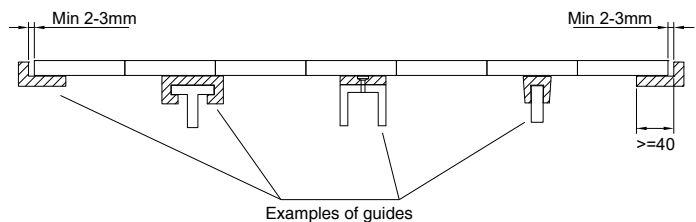

Type	Z [mm]	A [mm]	B1 [mm]	B2 [mm]	C _{max} [mm]
NMMD127G50	12	21,4	35	14	42
	14	25,5	37	14	50
	17	31,6	39	14	62
	19	35,7	40	14	70
	24	45,9	43	14	90
	36	69,5	53	14	130

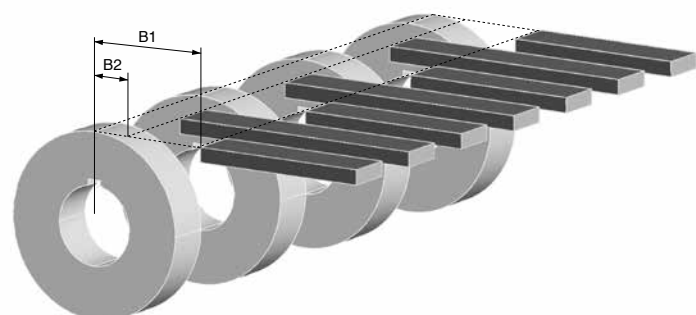

In order to avoid any subsidence of the belt in the area between the guiding strip and the sprockets, it is possible to locate the guides between the sprockets. Two minimum B1 and B2 dimensions are defined.

PITCH 12,7 mm / 0,5"

Belt type: closed flat top surface
Pin diameter: Ø 4,6 mm
Open area: 0%
Hole openings: -
Minimum width: 50 mm
Thickness: 10 mm
Nose bar diameter: 18-20 mm
Accessories: flights
Food Certification: FDA - EU

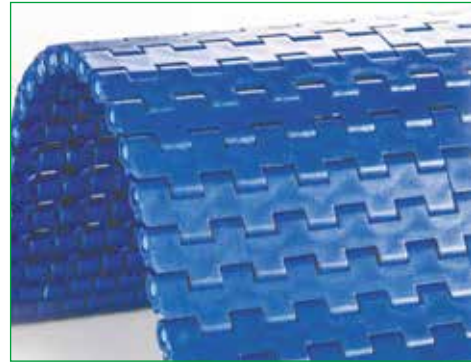

Standard executions

Belt material	Belt color	Pin
POM	Blue	Nylon
PP	Blue	POM

Other materials and colors are available upon request.

Belt material	Pin material	Belt performance [N/m]	Temperature range [°C]	Certification	Weight [kg/m ²]
PP	PP	11550	+5 ÷ +90	FDA - EU	4,75
PE	PE	7000	-73 ÷ +66	FDA - EU	5,00
POM	POM	16800	-43 ÷ +70	FDA - EU	7,10
POM	PA	17000	-40 ÷ +80	FDA - EU	6,90
POM	PP	16000	+5 ÷ +70	FDA - EU	6,90

PP = Polypropylene - PE = Polyethylene - POM = Acetal Resin - PA = Polyamide



Belt width [W]

Minimum [mm]	Standard increment [mm]	Special increment [mm]	Width tolerance* [mm]
50	Multiple: 50	Multiple: 16,7	+/-2 up to 300
			+/-3 up to 600
			+/-4 more than 600

**It is advisable to consider dimensional variations in width based on operating temperatures and humidity when the belt is made of polyamide.*

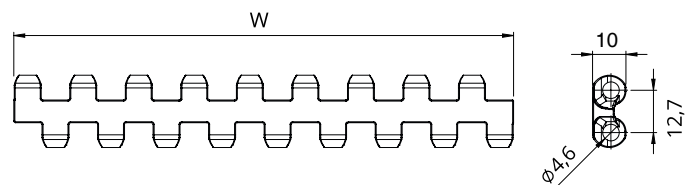

Part number	NMEC 127 C -PO -B	
Type	Belt color: B = blue	
Pitch	Belt material: PO = POM - Acetal Resin / PP = Polypropylene PE = Polyethylene / PA = Polyamide	
Closed flat top surface		

NMEC127FG

PITCH 12,7 mm / 0,5"

STRAIGHT MODULAR BELTS

Belt type: open flat surface flush grid

Pin diameter: Ø 4,6 mm

Open area: 20%

Hole openings: 3x6 mm

Minimum width: 50 mm

Thickness: 10 mm

Nose bar diameter: 18-20 mm

Accessories: flights

Food Certification: FDA - EU



Standard executions

Belt material	Belt color	Pin
POM	Blue	PA
PP	Blue	POM

Other materials and colors are available upon request.

Belt material	Pin material	Belt performance [N/m]	Temperature range [°C]	Certification	Weight [kg/m ²]
PP	PP	10900	+5 ÷ +90	FDA - EU	4,3
POM	POM	16000	-43 ÷ +70	FDA - EU	6,3
POM	PA	16200	-40 ÷ +80	FDA - EU	6,0
POM	PP	15200	+5 ÷ +70	FDA - EU	5,9

PP = Polypropylene - PE = Polyethylene - POM = Acetal Resin - PA = Polyamide

Belt width [W]

Minimum [mm]	Standard increment [mm]	Special increment [mm]	Width tolerance* [mm]
50	Multiple: 50	Multiple: 16,7	+/-2 up to 300
			+/-3 up to 600
			+/-4 more than 600

*It is advisable to consider dimensional variations in width based on operating temperatures and humidity when the belt is made of polyamide.

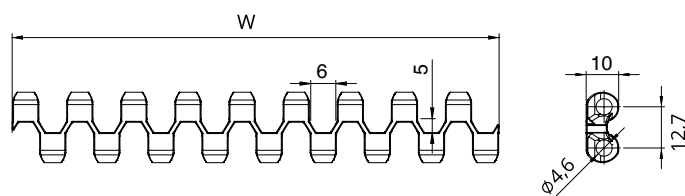

Part number

NMEC 127 FG -PO -B

Type

Pitch

Open flat surface flush grid

Belt color: B = blue

Belt material:
PO = POM - Acetal Resin / PP = Polypropylene
PA = Polyamide

PITCH 12,7 mm / 0,5"

- Belt type:** closed surface with rubber top insert
- Pin diameter:** Ø 4,6 mm
- Open area:** 0%
- Rubber hardness:** 50 Sh A, oil resistant
- Minimum width:** 50 mm
- Thickness:** 10+2,5 mm
- Nose bar diameter:** 18-20 mm
- Accessories:** flights
- Food Certification:** EU per colore white



Standard executions

Belt material	Belt color	Rubber color	Pin
PP	Gray	Black	POM-PP
PP	White	White	POM-PP

Other materials and colors are available upon request.

Belt material	Pin material	Belt performance [N/m]	Temperature range [°C]	Certification	Weight [kg/m²]
PP	PP	10900	+5 ÷ +50	FDA - EU	5,1

PP = Polypropylene - PE = Polyethylene - POM = Acetal Resin - PA = Polyamide

Belt width [W]

Minimum [mm]	Standard increment [mm]	Special increment [mm]	Width tolerance* [mm]
50	Multiple: 50	Multiple: 16,7	+/-2 up to 300
			+/-3 up to 600
			+/-4 more than 600

*It is advisable to consider dimensional variations in width based on operating temperatures and humidity when the belt is made of polyamide.

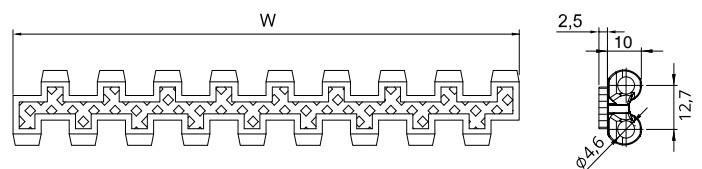

Part number	NMEC 127 GT -PP -G	
Type		Belt color: G = gray / W = white
Pitch		Belt material: PO = POM - Acetal Resin / PP = Polypropylene
Closed surface with rubber top insert		

Accessories for EC127 type

Flights

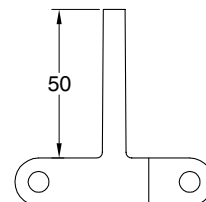
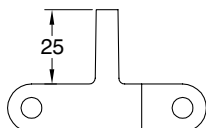

In case of need of flights the following table shows the standard indent. it is possible to have a special indent according to specific customer request.



Standard indent [mm]	Z	33	50	67	83

In the case of wide belts, one or more gaps is recommended between flights to allow the belt to be supported on the return path. The maximum width not supported by guides depends on several factors such as the load on the belt, possible incline of the conveyor, and belt or pin material.

Sprockets for EC127 type

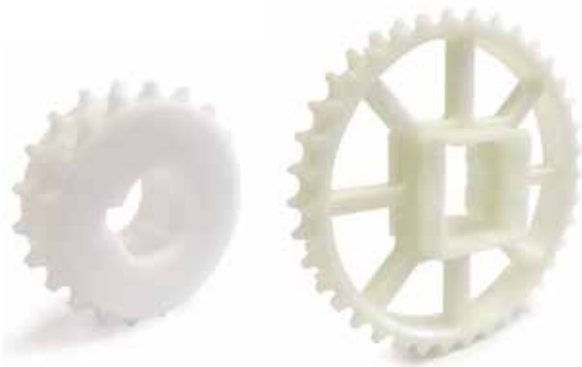

Part number NSEC127 -Q 40 -Z24

Type _____

Bore type: R = round / Q = square _____

Bore dimension (mm) _____

Teeth nr. _____

Teeth nr.	Dp [mm]	Do [mm]	A [mm]	B [mm]	Available standard bore	
					Square [mm]	Ø round + set-screw UNI
19	77,3	78,1	40	3,5	40x40	20 - 25 - 30
24	97,6	99,0	40	3,5	40x40	20 - 25 - 30
28	113,9	115,3	40	3,5	40x40	25 - 30
30	122,0	123,4	40	3,5	40x40	25 - 30
36	146,4	147,9	40	3,5	40x40	25 - 30

Standard material: nylon PA6 fiberglass.
 It is possible to supply sprocket with any number of teeth or any material by CNC machining
 Dp = Pitch diameter
 Do = External tooth diameter

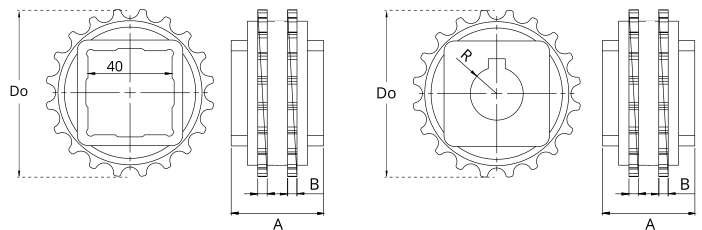

		Belt width [mm]													
		150	200	250	300	350	400	450	500	550	600	650	700	750	
Number of sprockes	Drive shaft	Belt tension ≤ 50% of the capacity	2	2	3	3	4	4	5	5	6	6	7	7	8
		Belt tension = 100% of the capacity	3	3	4	5	6	8	9	10	11	12	13	14	15
Driven shaft		2	2	2	2	2	2	3	3	3	3	4	4	4	
Sliding guides		2	2	3	3	3	4	4	4	5	5	5	6	6	

		Belt width [mm]													
		800	850	900	950	1000	1050	1100	1150	1200	1250	1300	1350	1400	
Number of sprockes	Drive shaft	Belt tension ≤ 50% of the capacity	8	9	9	10	10	11	11	12	12	13	13	14	14
		Belt tension = 100% of the capacity	15	16	17	18	19	20	21	22	23	24	25	26	27
Driven shaft		4	4	5	5	5	5	6	6	7	7	8	8	8	
Sliding guides		6	7	7	7	8	8	8	9	9	9	10	10	11	

Mounting

When mounting the sprockets, make sure that you have mounted all sprockets oriented in the same phase.
 Only axially lock the central sprocket and leave the other sprockets free to move axially.

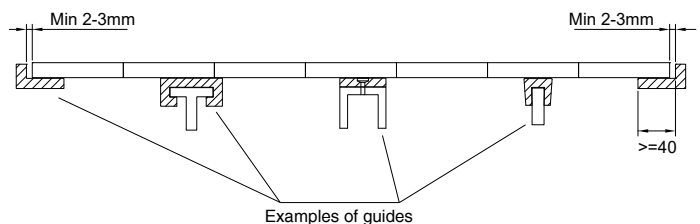

Sprockets for EC127 type

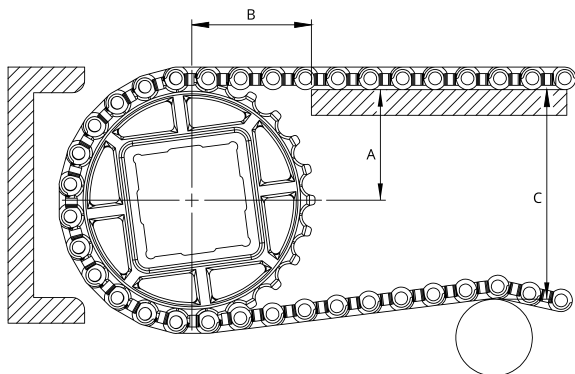

Type	Teeth nr.	A _{max} [mm]	A _{min} [mm]	B1 [mm]	B2 [mm]	C _{max} [mm]
NMEC127C	19	34,4	34,0	40	15	70
	24	44,8	44,4	43	15	90
	28	52,9	52,6	47	15	105
NMEC127FG	30	57,3	57,0	49	15	113
	36	70,0	68,8	53	15	137

A_{max} = sliding surface position so that the height of the belt engaging the sprocket oscillates between the sliding surface height and a lower one. The height variation depends on the number of teeth and the pitch of the sprocket.

A_{min} = sliding surface position so that the height of the belt engaging the sprocket oscillates between the sliding surface height and a higher one. The height variation depends on the number of teeth and the pitch of the sprocket.

The choice of A dimensions depends on the items you have to carry. it is always suggested to make a chamfer at the end of the sliding guides.

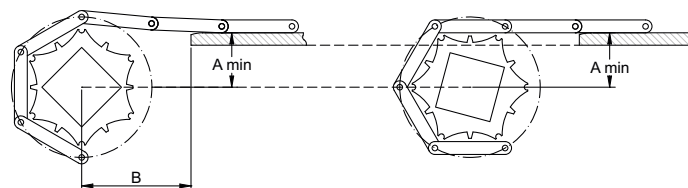
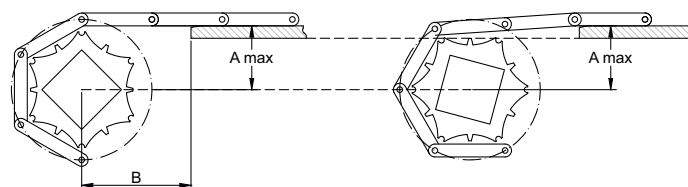

In order to avoid any subsidence of the belt in the area between the guiding strip and the sprockets, it is possible to locate the guides between the sprockets. Two minimum B1 and B2 dimensions are defined.

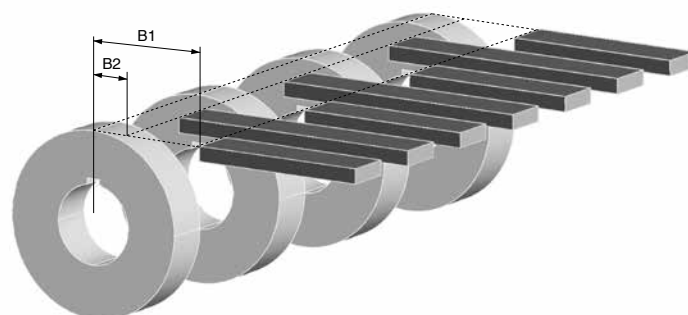

PITCH 25,4 mm / 1"

Belt type: closed flat top surface
Pin diameter: Ø 5 mm
Open area: 0%
Hole openings: -
Minimum width: 152,4 mm
Thickness: 10 mm
Accessories: flights - side wall
Food Certification: FDA - EU



Standard executions

Belt material	Belt color	Pin
PP	White - blue	PP
PE	Blue	POM

Other materials and colors are available upon request.

Belt material	Pin material	Belt performance [N/m]	Temperature range [°C]	Certification	Weight [kg/m²]
PP	PP	11700	+5 ÷ +90	FDA - EU	4,5
PE	PE	10500	-73 ÷ +66	FDA - EU	5,0
POM	POM	14600	-43 ÷ +70	FDA - EU	6,6
POM	PA	15700	-40 ÷ +80	FDA - EU	6,4
POM	PP	12900	+5 ÷ +70	FDA - EU	6,4

PP = Polypropylene - PE = Polyethylene - POM = Acetal Resin - PA = Polyamide



Belt width [W]

Minimum [mm]	Standard increment [mm]	Special increment [mm]	Width tolerance* [mm]
152,4	Multiple: 76,2	Multiple: 15,24	+/-2 up to 300
			+/-3 up to 600
			+/-4 more than 600

*It is advisable to consider dimensional variations in width based on operating temperatures and humidity when the belt is made of polyamide.

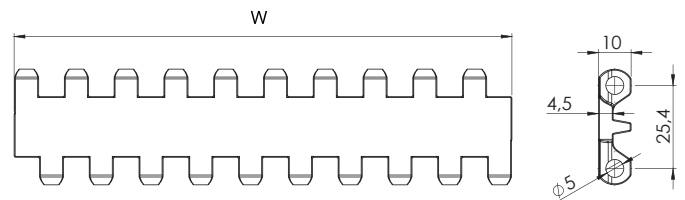

Part number	NMEC 254 C -PO -W	
Type	Belt color: W = white / B = blue	Belt material: PO = POM - Acetal Resin / PP = Polypropylene PE = Polyethylene / PA = Polyamide
Pitch		
Closed flat top surface		

NMEC254P16

PITCH 25,4 mm / 1"

STRAIGHT MODULAR BELTS

- Belt type:** open flat surface
- Pin diameter:** Ø 5 mm
- Open area:** 16%
- Hole openings:** 2,5x3,7 mm
- Minimum width:** 152,4 mm
- Thickness:** 10 mm
- Accessories:** flights - side wall
- Food Certification:** FDA - EU



Standard executions

Belt material	Belt color	Pin
PP	White - blue	PP
PE	Blue	POM

Other materials and colors are available upon request.

Belt material	Pin material	Belt performance [N/m]	Temperature range [°C]	Certification	Weight [kg/m²]
PP	PP	9360	+5 ÷ +90	FDA - EU	3,8
PE	PE	8500	-73 ÷ +66	FDA - EU	4,2
POM	POM	13100	-43 ÷ +70	FDA - EU	5,7
POM	PA	14000	-40 ÷ +80	FDA - EU	5,5
POM	PP	11500	+5 ÷ +70	FDA - EU	5,5

PP = Polypropylene - PE = Polyethylene - POM = Acetal Resin - PA = Polyamide

Belt width [W]

Minimum [mm]	Standard increment [mm]	Special increment [mm]	Width tolerance* [mm]
152,4	Multiple: 76,2	Multiple: 15,24	+/-2 up to 300
			+/-3 up to 600
			+/-4 more than 600

*It is advisable to consider dimensional variations in width based on operating temperatures and humidity when the belt is made of polyamide.

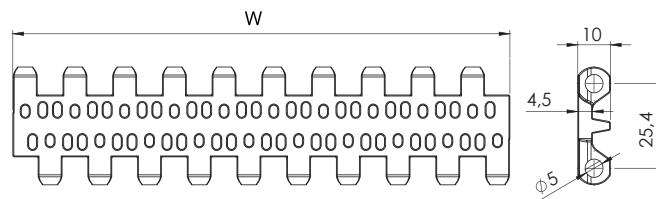

Part number

NMEC 254 P16 -PO -W

Type _____

Pitch _____

Open flat surface 16%

Belt color: W = white / B = blue

Belt material:
 PO = POM - Acetal Resin / PP = Polypropylene
 PE = Polyethylene / PA = Polyamide

PITCH 25,4 mm / 1"

Belt type: closed nub top surface
Pin diameter: Ø 5 mm
Open area: 0%
Hole openings: -
Minimum width: 152,4 mm
Thickness: 10+2 mm
Accessories: flights - side wall
Food Certification: FDA - EU

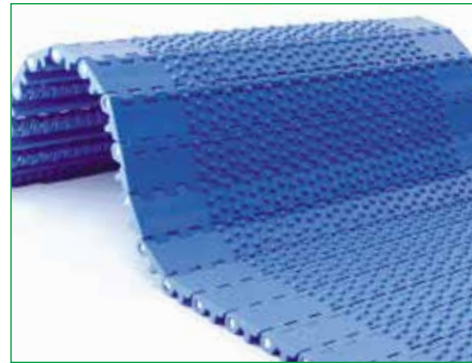

Standard executions

Belt material	Belt color	Pin
PP	White - blue	PP

Other materials and colors are available upon request.

Belt material	Pin material	Belt performance [N/m]	Temperature range [°C]	Certification	Weight [kg/m ²]
PP	PP	11700	+5 ÷ +90	FDA - EU	4,7
PE	PE	10500	-73 ÷ +66	FDA - EU	5,2
POM	POM	14600	-43 ÷ +70	FDA - EU	6,8
POM	PA	15700	-40 ÷ +80	FDA - EU	6,6
POM	PP	12900	+5 ÷ +70	FDA - EU	6,6

PP = Polypropylene - PE = Polyethylene - POM = Acetal Resin - PA = Polyamide

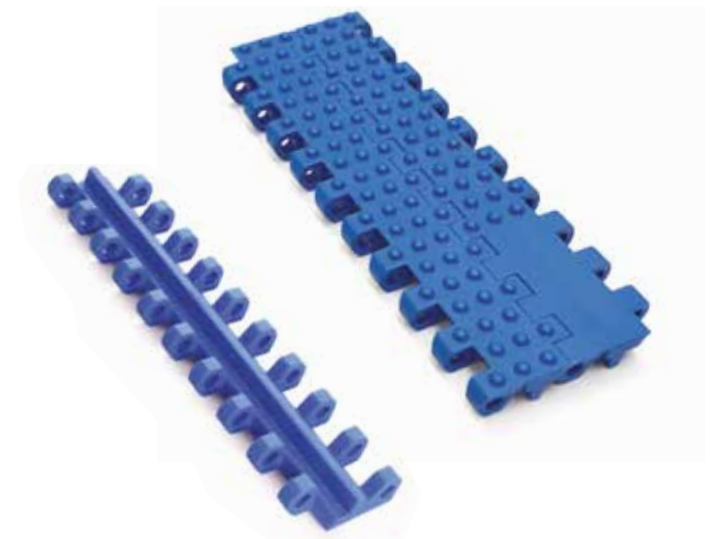

Belt width [W]

Minimum [mm]	Standard increment [mm]	Special increment [mm]	Width tolerance* [mm]
152,4	Multiple: 76,2	Multiple: 15,24	+/-2 up to 300
			+/-3 up to 600
			+/-4 more than 600

*It is advisable to consider dimensional variations in width based on operating temperatures and humidity when the belt is made of polyamide.

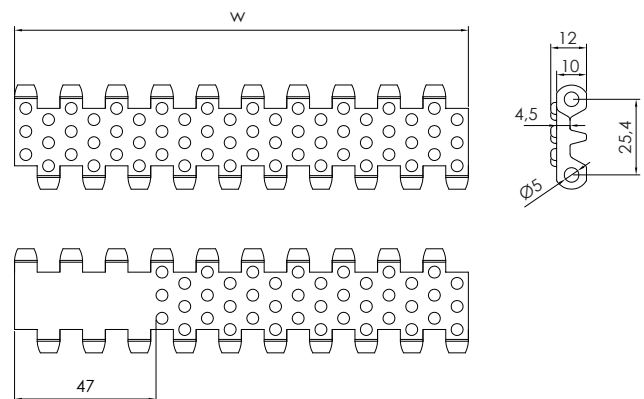

Part number	NMEC 254 NT -PP -B	
Type	Belt color: W = white / B = blue	
Pitch	Belt material: PO = POM - Acetal Resin / PP = Polypropylene PE = Polyethylene / PA = Polyamide	
Closed nub top surface		

Accessories for EC254 type

Flights

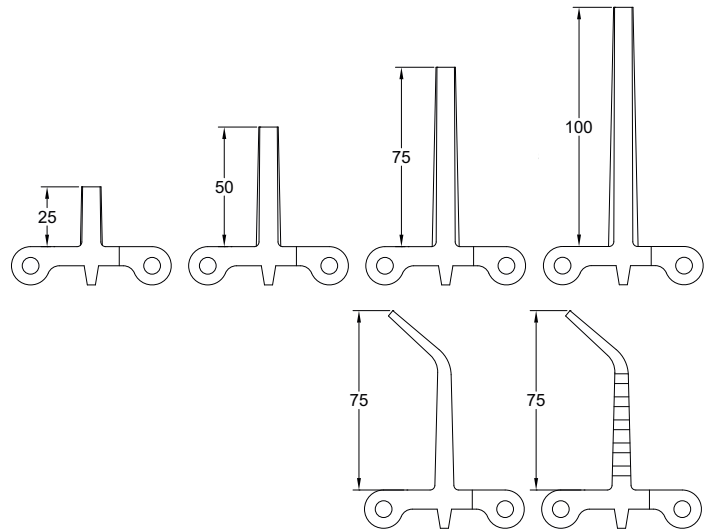
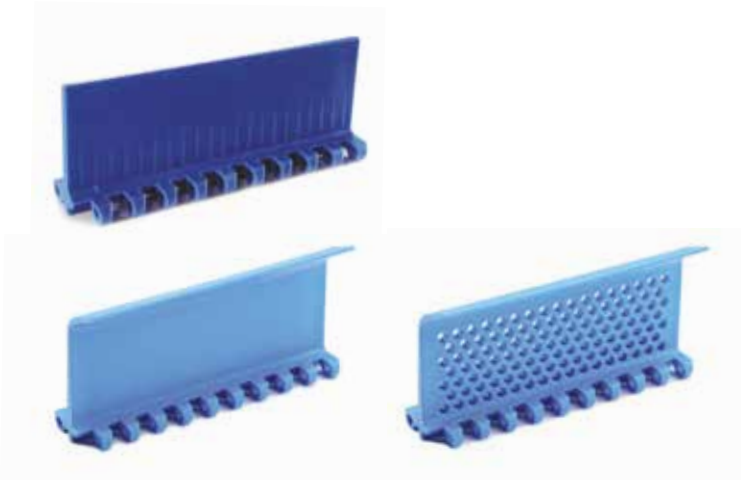

In case of need of flights the following table shows the standard indent. it is possible to have a special indent according to specific customer request.



Standard indent [mm]	Z	30	45	60	72

In the case of wide belts, one or more gaps is recommended between flights to allow the belt to be supported on the return path. The maximum width not supported by guides depends on several factors such as the load on the belt, possible incline of the conveyor, and belt or pin material.

Side wall

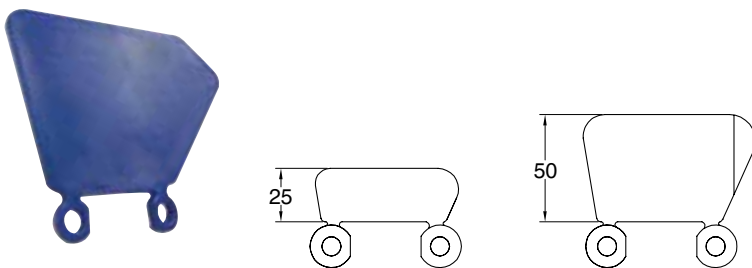

Inner and outer side wall indent [mm]	Y _i	16	23	30	38	46	53
	Y _e	23	30	37	45	53	60

STRAIGHT MODULAR BELTS

Sprockets for EC254 type



Teeth nr.	Dp [mm]	Do [mm]	A [mm]	B [mm]	Available standard bore	
					Square [mm]	Ø round + set-screw UNI
8	68,4	64,6	40	30	25x25	25
10	82,2	83,0	40	30	40x40	25 - 30
12	98,1	98,0	40	30	40x40	25 - 30
15	122,2	123,0	40	30	40x40	25 - 30
18	146,3	147,5	40	30	40x40	25 - 30

Standard material: nylon PA6 fiberglass.
 It is possible to supply sprocket with any number of teeth or any material by CNC machining
 Dp = Pitch diameter
 Do = External tooth diameter

Part number NSEC254 -Q 40 -Z12

Type _____

Bore type: R = round / Q = square _____

Bore dimension (mm) _____

Teeth nr. _____

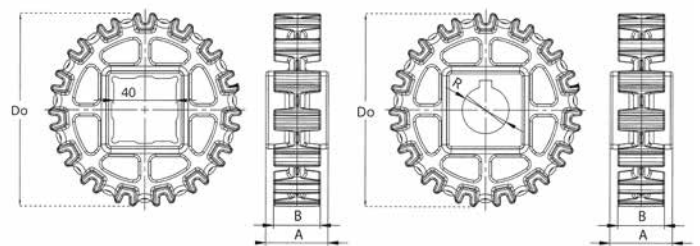

Belt width [mm]		152,4	228,6	304,8	381,0	457,2	533,4	609,6	685,8	762,0	838,2	914,4	990,6	1066,8		
Number of sprockes	Drive shaft	Belt tension ≤ 50% of the capacity		2	2	3	4	5	5	6	6	7	7	8	8	9
		Belt tension = 100% of the capacity		2	3	4	5	6	7	8	9	10	11	13	14	15
Driven shaft		2	2	2	2	3	3	3	4	4	4	4	5	5		
Sliding guides		2	3	3	4	4	5	5	6	6	7	7	8	8		

Belt width [mm]		1143,0	1219,2	1295,4	1371,6	1447,8	1524,0	1600,2	1676,4	1752,6	1828,8	1905	1981,2	2057,4		
Number of sprockes	Drive shaft	Belt tension ≤ 50% of the capacity		9	10	10	11	11	12	12	12	13	14	14	15	15
		Belt tension = 100% of the capacity		16	17	18	19	20	21	22	23	25	26	27	28	29
Driven shaft		5	6	6	7	7	7	8	8	8	9	9	10	10		
Sliding guides		9	9	10	10	11	11	12	12	13	13	14	14	15		

Mounting

When mounting the sprockets, make sure that you have mounted all sprockets oriented in the same phase.
 Only axially lock the central sprocket and leave the other sprockets free to move axially.

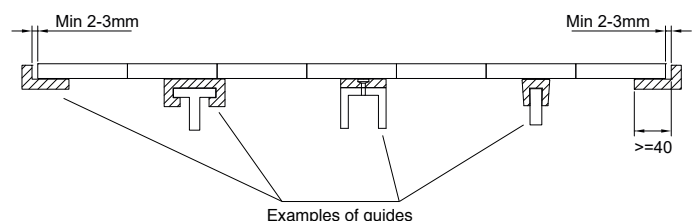

Sprockets for EC254 type

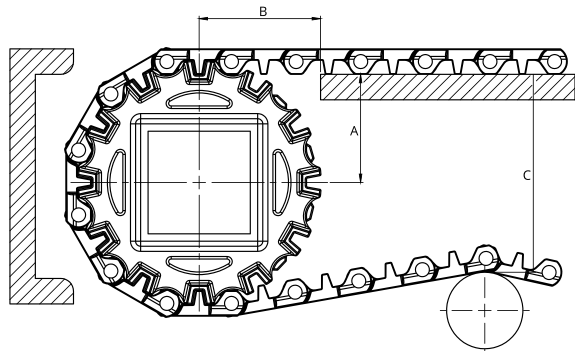

Teeth nr.	A_{max} [mm]	A_{min} [mm]	B1 [mm]	B2 [mm]	C_{max} [mm]
8	28,2	25,7	39	28	58
10	36,5	34,0	41	28	75
12	44,2	42,2	45	28	91
15	56,2	54,6	51	28	116
18	68,2	67,0	55	28	140

A_{max} = sliding surface position so that the height of the belt engaging the sprocket oscillates between the sliding surface height and a lower one. The height variation depends on the number of teeth and the pitch of the sprocket.

A_{min} = sliding surface position so that the height of the belt engaging the sprocket oscillates between the sliding surface height and a higher one. The height variation depends on the number of teeth and the pitch of the sprocket.

The choice of A dimensions depends on the items you have to carry. it is always suggested to make a chamfer at the end of the sliding guides.

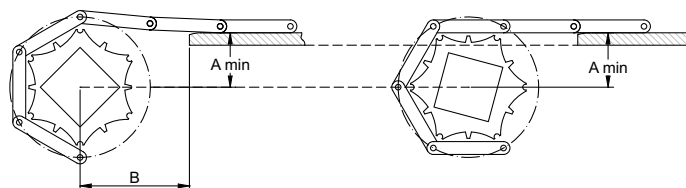
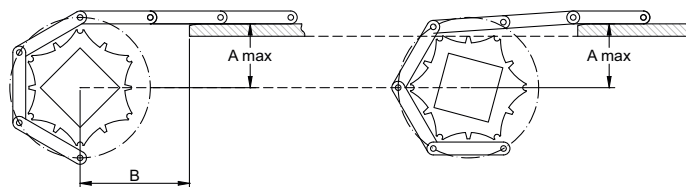

In order to avoid any subsidence of the belt in the area between the guiding strip and the sprockets, it is possible to locate the guides between the sprockets. Two minimum B1 and B2 dimensions are defined.

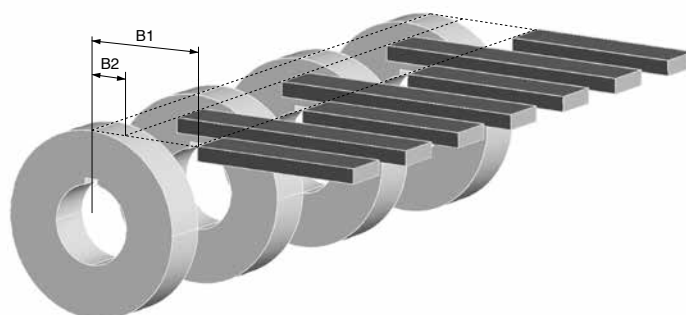

PITCH 25,4 mm / 1"

Belt type: closed flat top surface
Pin diameter: Ø 5 mm
Open area: 0%
Hole openings: -
Minimum width: 200 mm
Thickness: 10 mm
Accessories: flights - side wall
Food Certification: FDA - EU

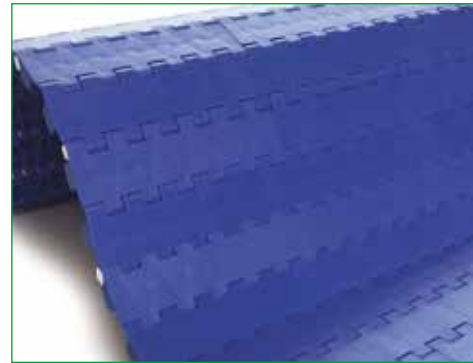

Standard executions

Belt material	Belt color	Pin
PP	White - blue	PP
POM	White - blue	PA

Other materials and colors are available upon request.

Belt material	Pin material	Belt performance [N/m]	Temperature range [°C]	Certification	Weight [kg/m²]
PP	PP	14200	+5 ÷ +90	FDA - EU	6,1
PE	PE	7800	-73 ÷ +66	FDA - EU	7,1
POM	POM	19000	-43 ÷ +70	FDA - EU	9,4
POM	PA	20100	-40 ÷ +80	FDA - EU	9,2
POM	PP	16700	+5 ÷ +70	FDA - EU	9,2

PP = Polypropylene - PE = Polyethylene - POM = Acetal Resin - PA = Polyamide



Belt width [W]

Minimum [mm]	Standard increment [mm]	Special increment [mm]	Width tolerance* [mm]
200	Multiple: 50	Multiple: 16,7	+/-2 up to 300
			+/-3 up to 600
			+/-4 more than 600

*It is advisable to consider dimensional variations in width based on operating temperatures and humidity when the belt is made of polyamide.

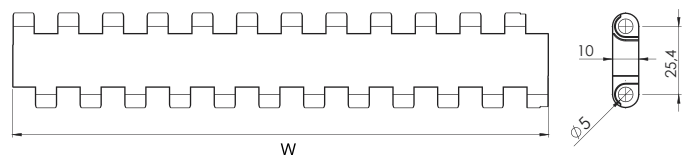

Part number

NMMD 254 C -PO -W

Type
 Pitch
 Closed flat top surface

Belt color: W = white / B = blue

Belt material:
 PO = POM - Acetal Resin / PP = Polypropylene
 PE = Polyethylene / PA = Polyamide

NMMD254FG

PITCH 25,4 mm / 1"

STRAIGHT MODULAR BELTS

- Belt type:** open flat surface flush grid
- Pin diameter:** Ø 5 mm
- Open area:** 35%
- Hole openings:** 5,5x7 mm
- Minimum width:** 200 mm
- Thickness:** 10 mm
- Accessories:** flights - side wall
- Food Certification:** FDA - EU



Standard executions

Belt material	Belt color	Pin
PP	White - blue - gray	PP
POM	Blue	PA

Other materials and colors are available upon request.

Belt material	Pin material	Belt performance [N/m]	Temperature range [°C]	Certification	Weight [kg/m ²]
PP	PP	14200	+5 ÷ +90	FDA - EU	5,7
PE	PE	7800	-73 ÷ +66	FDA - EU	6,6
POM	POM	19000	-43 ÷ +70	FDA - EU	8,8
POM	PA	20100	-40 ÷ +80	FDA - EU	8,6
POM	PP	16700	+5 ÷ +70	FDA - EU	8,6

PP = Polypropylene - PE = Polyethylene - POM = Acetal Resin - PA = Polyamide

Belt width [W]

Minimum [mm]	Standard increment [mm]	Special increment [mm]	Width tolerance* [mm]
200	Multiple: 50	Multiple: 16,7	+/-2 up to 300
			+/-3 up to 600
			+/-4 more than 600

*It is advisable to consider dimensional variations in width based on operating temperatures and humidity when the belt is made of polyamide.



Part number

NMMD 254 FG -PO -W

Type _____

Pitch _____

Open flat surface flush grid _____

Belt color: W = white / B = blue / G = gray

Belt material:
 PO = POM - Acetal Resin / PP = Polypropylene
 PE = Polyethylene / PA = Polyamide

PITCH 25,4 mm / 1"

Belt type: open flat surface
Pin diameter: Ø 5 mm
Open area: 48%
Hole openings: 9x13,5 e 6x16,5
Minimum width: 203,4 mm
Thickness: 11 mm
Accessories: -
Food Certification: FDA - EU



Standard executions

Belt material	Belt color	Pin
POM	White - blue	PA
PHT	Black	AISI 304

Other materials and colors are available upon request.

Belt material	Pin material	Belt performance [N/m]	Temperature range [°C]	Certification	Weight [kg/m ²]
PP	PP	8400	+5 ÷ +90	FDA - EU	5,0
POM	PA	15100	-40 ÷ +80	FDA - EU	6,6
POM	PP	12400	+5 ÷ +70	FDA - EU	6,6
PHT	AISI 304	13500	+10 ÷ +160	-	8,1

PP = Polypropylene - PE = Polyethylene - POM = Acetal Resin - PA = Polyamide



Belt width [W]

Minimum [mm]	Standard increment [mm]	Special increment [mm]	Width tolerance* [mm]
203,4	Multiple: 33,8	-	+/-2 up to 300
			+/-3 up to 600
			+/-4 more than 600

*It is advisable to consider dimensional variations in width based on operating temperatures and humidity when the belt is made of polyamide.

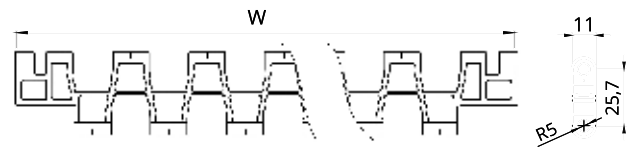

Part number

NMMD 254 G48 -PO -W

Type _____
 Pitch _____
 Open flat surface at 48%

Belt color: W = white / B = blue / K = black

Belt material:
 PO = POM - Acetal Resin / PP = Polypropylene
 HT = PHT - Compound for high temperature

NMMD254GT

PITCH 25,4 mm / 1"

STRAIGHT MODULAR BELTS

- Belt type:** closed grip top surface - indent 50 mm
- Pin diameter:** Ø 5 mm
- Open area:** 0%
- Hole openings:** -
- Minimum width:** 100 mm
- Thickness:** 10+4 mm
- Accessories:** flights - side wall
- Food Certification:** FDA - EU



Standard executions

Belt material	Belt color	Rubber color	Pin
PP	White	White	PP-POM
PP	Blue	Black	PP-POM

Other materials and colors are available upon request.

Belt material	Pin material	Belt performance [N/m]	Temperature range [°C]	Certification	Weight [kg/m ²]
PP	PP	14200	+5 ÷ +50	FDA - EU	6,9
PE	PE	7800	-10 ÷ +50	FDA - EU	8,0

PP = Polypropylene - PE = Polyethylene - POM = Acetal Resin - PA = Polyamide

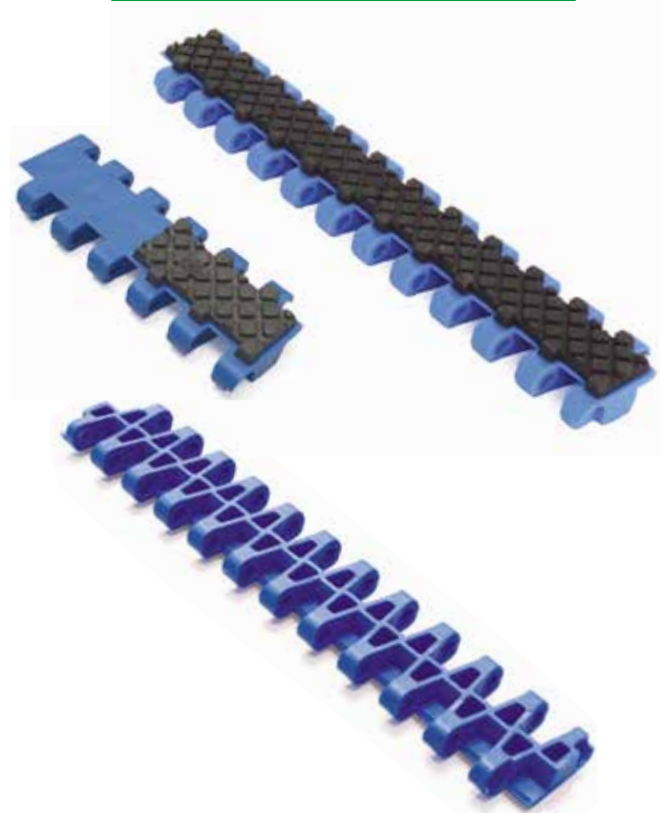

Belt width [W]

Minimum [mm]	Standard increment [mm]	Special increment [mm]	Width tolerance* [mm]
200	Multiple: 50	Multiple: 16,7	+/-2 up to 300
			+/-3 up to 600
			+/-4 more than 600

*It is advisable to consider dimensional variations in width based on operating temperatures and humidity when the belt is made of polyamide.

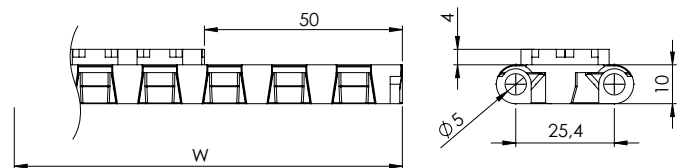

Part number

NMMD 254 GT -PP -W

Type _____
 Pitch _____
 Closed grip top surface - indent 50 mm

Belt color: W = white / B = blue

Belt material:
 PO = POM - Acetal Resin / PP = Polypropylene
 PE = Polyethylene

PITCH 25,4 mm / 1"

Belt type: open flat surface rised rib
Pin diameter: Ø 5 mm
Open area: 35%
Surface contact with the product: 12%
Minimum width: 100 mm
Thickness: 16 mm
Accessories: loading and unloading comb
Food Certification: FDA - EU

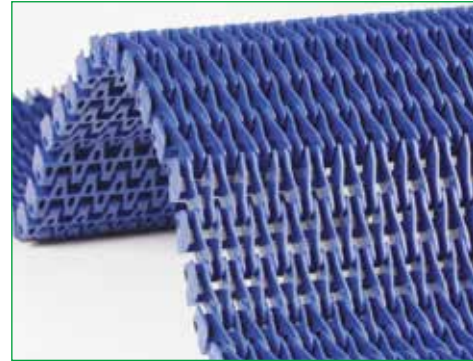

Standard executions

Belt material	Belt color	Pin
PP	White - Blue	PP-POM
POM	Blue	POM-PA

Other materials and colors are available upon request.

Belt material	Pin material	Belt performance [N/m]	Temperature range [°C]	Certification	Weight [kg/m ²]
PP	PP	14200	+5 ÷ +70	FDA - EU	5,2
PPH	PPH	14800	+5 ÷ +105	FDA - EU	5,2
POM	PA	20100	-43 ÷ +80	FDA - EU	8,0

PP = Polypropylene - PE = Polyethylene - POM = Acetal Resin - PA = Polyamide

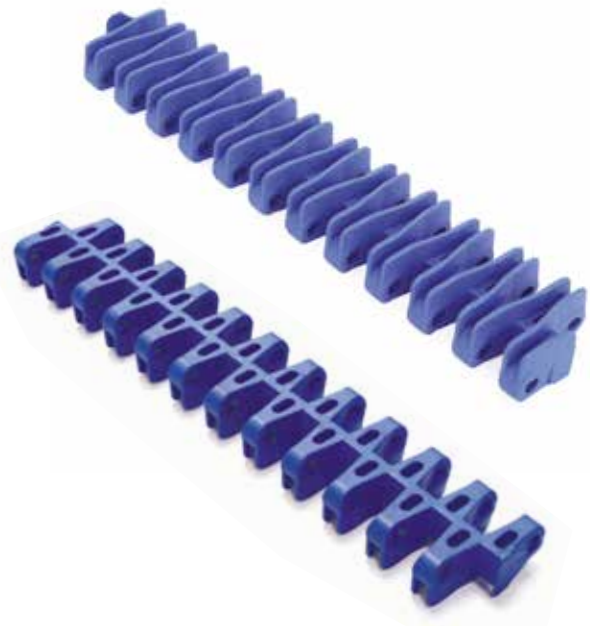

Belt width [W]

Minimum [mm]	Standard increment [mm]	Special increment [mm]	Width tolerance* [mm]
100	Multiple: 50	Multiple: 16,7	+/-2 up to 300
			+/-3 up to 600
			+/-4 more than 600

*It is advisable to consider dimensional variations in width based on operating temperatures and humidity when the belt is made of polyamide.

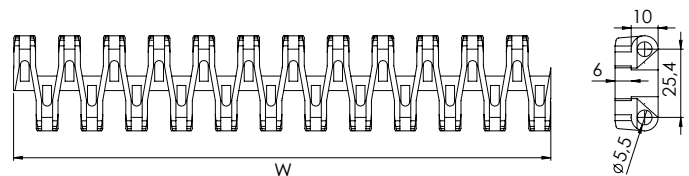

Part number

NMMD 254 RR -PP -W

Type _____
 Pitch _____
 Open flat surface rised rib

Belt color: W = white / B = blue

Belt material:
 PO = POM - Acetal Resin / PP = Polypropylene
 HT = PHT - Compound for high temperature / PA = Polyamide

Accessories for NMMD254C and NMMD254FG type

Flights

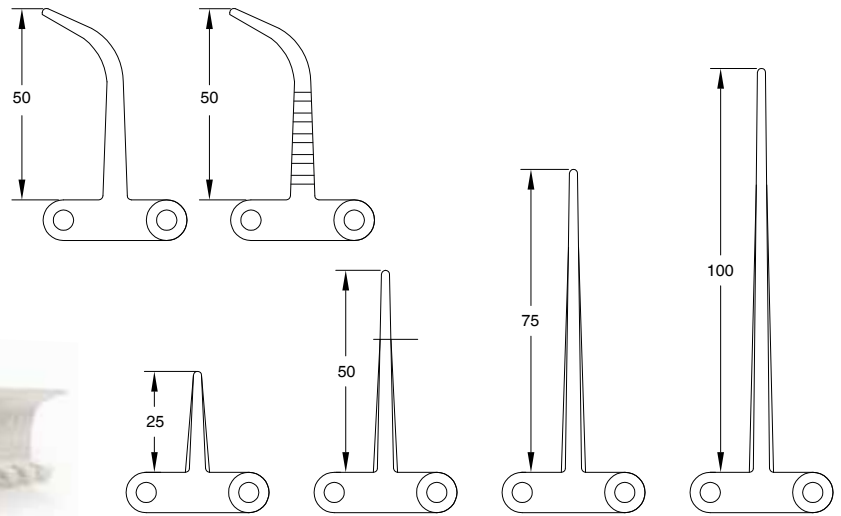
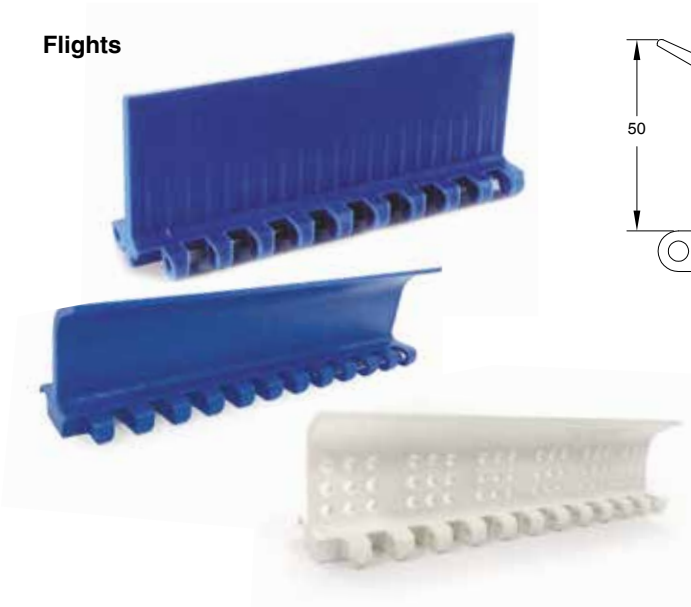

In case of need of flights the following table shows the standard indent. it is possible to have a special indent according to specific customer request.



Standard indent [mm]	Z	33	50	75

In the case of wide belts, one or more gaps is recommended between flights to allow the belt to be supported on the return path. The maximum width not supported by guides depends on several factors such as the load on the belt, possible incline of the conveyor, and belt or pin material.

Side wall

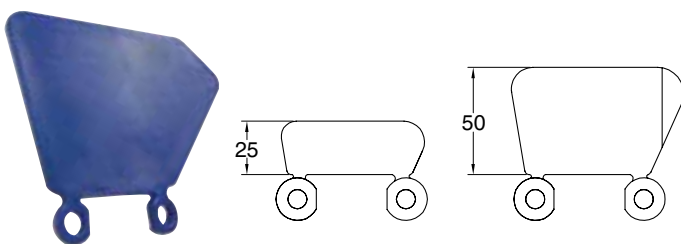

Inner and outer side wall indent [mm]	Y _i	25	33	41	50	58	66
	Y _e	34	42	50	59	67	75

Comb for belt NMMD254RR type

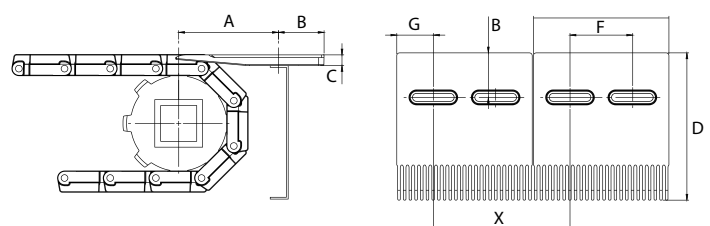

Quote [mm]	A	B	C	D	E	F	G	X
	105-115	25	12,5	146	150	75	37,5	155

Sprockets for MD254 type



Teeth nr.	Dp [mm]	Do [mm]	A [mm]	B [mm]	Available standard bore	
					Square [mm]	Ø round + set-screw UNI
8	68,4	67,7	40	6	25x25	25
10	82,8	85,7	40	6	40x40	25 - 30
12	98,9	102,0	40	6	40x40	25 - 30
15	123,1	126,0	40	6	40x40	25 - 30
18	147,4	152,3	40	6	40x40	25 - 30

Standard material: nylon PA6 fiberglass.
 It is possible to supply sprocket with any number of teeth or any material by CNC machining
 Dp = Pitch diameter
 Do = External tooth diameter

Part number NSMD254 -Q 40 -Z12

Type _____

Bore type: R = round / Q = square _____

Bore dimension (mm) _____

Teeth nr. _____

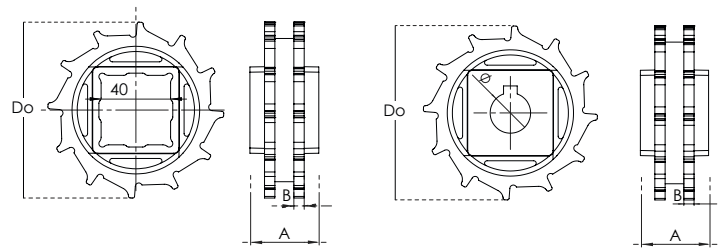

Belt width [mm]		200	300	400	500	600	700	800	900	1000	1100	1200	1400	1600	
Number of sprockes	Drive shaft	Belt tension ≤ 50% of the capacity	2	3	4	5	6	6	7	8	8	9	10	11	13
		Belt tension = 100% of the capacity	2	4	5	6	8	9	11	13	14	16	17	19	22
Driven shaft			2	2	3	3	3	4	4	4	5	5	6	6	7
Sliding guides			2	3	4	4	5	6	7	7	8	9	9	10	12

Belt width [mm]		1800	2000	2200	2400	2600	
Number of sprockes	Drive shaft	Belt tension ≤ 50% of the capacity	14	15	16	18	20
		Belt tension = 100% of the capacity	25	28	30	32	34
Driven shaft			8	9	10	11	12
Sliding guides			13	14	15	17	19

Mounting

When mounting the sprockets, make sure that you have mounted all sprockets oriented in the same phase.
 Only axially lock the central sprocket and leave the other sprockets free to move axially.

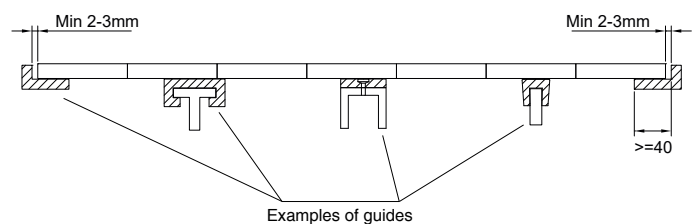

Sprockets for MD254 type

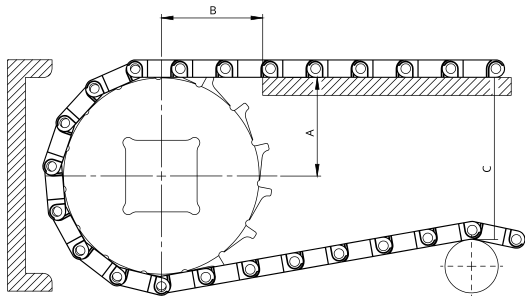

Teeth nr.	A _{max} [mm]	A _{min} [mm]	B1 [mm]	B2 [mm]	C _{max} [mm]
8	28,7	26,1	38	28	54
10	37,7	36,3	40	28	75
12	45,2	43,6	44	28	91
15	56,5	54,5	50	28	116
18	67,8	65,4	57	28	140

A_{max} = sliding surface position so that the height of the belt engaging the sprocket oscillates between the sliding surface height and a lower one. The height variation depends on the number of teeth and the pitch of the sprocket.

A_{min} = sliding surface position so that the height of the belt engaging the sprocket oscillates between the sliding surface height and a higher one. The height variation depends on the number of teeth and the pitch of the sprocket.

The choice of A dimensions depends on the items you have to carry. it is always suggested to make a chamfer at the end of the sliding guides.

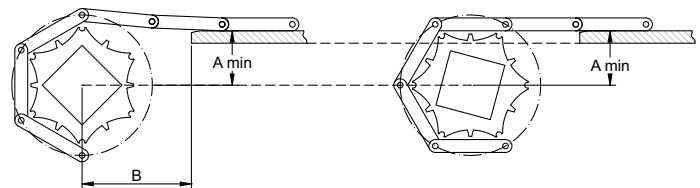
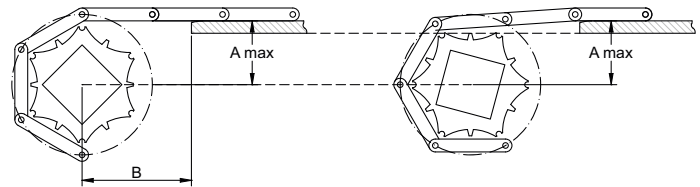

In order to avoid any subsidence of the belt in the area between the guiding strip and the sprockets, it is possible to locate the guides between the sprockets. Two minimum B1 and B2 dimensions are defined.

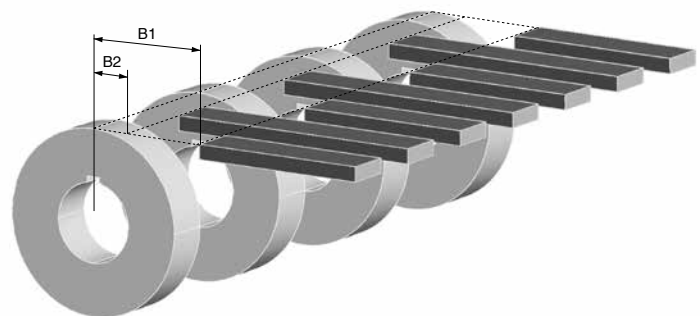

PITCH 25,4 mm / 1"

- Belt type:** open flat surface flush grid
- Pin diameter:** Ø 4,5 mm
- Open area:** 24%
- Hole openings:** 9,4x8,4 / 9,4x1,2 mm
- Minimum width:** 152,4 mm
- Thickness:** 8,8 mm
- Accessories:** flights - side wall

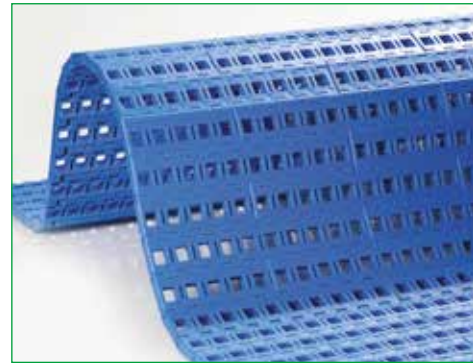

Standard executions

Belt material	Belt color	Pin
PP	Blue - white	PP
POM	Blue	PA

Other materials and colors are available upon request.

Belt material	Pin material	Belt performance [N/m]	Range di temperature [°C]	Weight [kg/m²]
PP	PP	11300	+5 ÷ +90	5,3
PE	PE	10000	-73 ÷ +66	5,4
POM	PA	22500	-40 ÷ +80	7,4
POM	PP	18100	+5 ÷ +70	7,4

PP = Polypropylene - PE = Polyethylene - POM = Acetal Resin - PA = Polyamide



Belt width [W]

Minimum [mm]	Standard increment [mm]	Special increment [mm]	Width tolerance* [mm]
152,4	Multiple: 76,2	Multiple: 15,24	+/-2 up to 300
			+/-3 up to 600
			+/-4 more than 600

*It is advisable to consider dimensional variations in width based on operating temperatures and humidity when the belt is made of polyamide.

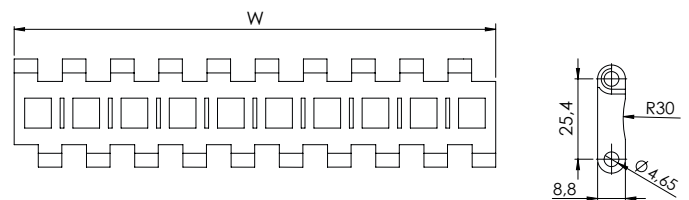

Part number	NMXP 254 FG -PP -W	
Type	Belt color: W = white / B = blue	
Pitch	Belt material: PO = POM - Acetal Resin / PP = Polypropylene PE = Polyethylene / PA = Polyamide	
Open flat surface flush grid		

NMXP254P22

PITCH 25,4 mm / 1"

STRAIGHT MODULAR BELTS

- Belt type:** flat perforated surface
- Pin diameter:** Ø 4,5 mm
- Open area:** 19%
- Hole openings:** 9,4x3 / 9,4x1,2 mm
- Minimum width:** 152,4 mm
- Thickness:** 8,8 mm
- Accessories:** flights - side wall

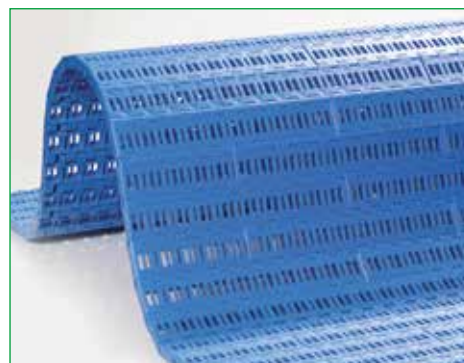

Standard executions

Belt material	Belt color	Pin
PP	Blue - white	PP
POM	Blue	PA

Other materials and colors are available upon request.

Belt material	Pin material	Belt performance [N/m]	Range di temperature [°C]	Weight [kg/m²]
PP	PP	13100	+5 ÷ +90	5,3
PE	PE	11600	-73 ÷ +66	5,5
POM	PA	25500	-40 ÷ +80	7,5
POM	PP	21000	+5 ÷ +70	7,5

PP = Polypropylene - PE = Polyethylene - POM = Acetal Resin - PA = Polyamide



Belt width [W]

Minimum [mm]	Standard increment [mm]	Special increment [mm]	Width tolerance* [mm]
152,4	Multiple: 76,2	Multiple: 15,24	+/-2 up to 300
			+/-3 up to 600
			+/-4 more than 600

*It is advisable to consider dimensional variations in width based on operating temperatures and humidity when the belt is made of polyamide.

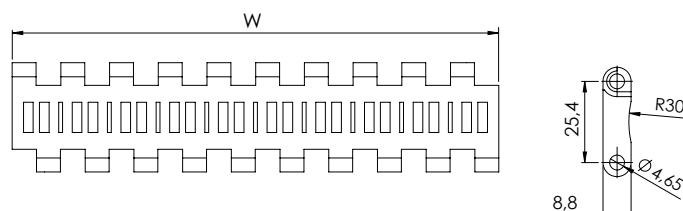

Part number

NMXP 254 P17 -PP -W

Type

Pitch

Flat perforated surface at 17%

Belt color: W = white / B = blue

Belt material:
 PO = POM - Acetal Resin / PP = Polypropylene
 PE = Polyethylene / PA = Polyamide

PITCH 25,4 mm / 1"

Belt type: closed flat top surface
Pin diameter: Ø 4,5 mm
Open area: 0%
Hole openings: -
Minimum width: 152,4 mm
Thickness: 8,8 mm
Accessories: flights - side wall

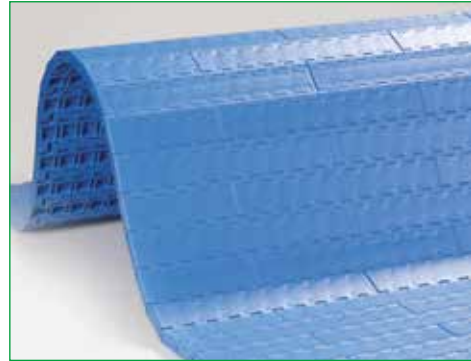

Standard executions

Belt material	Belt color	Pin
PP	Blue - white	PP
POM	Blue	PA

Other materials and colors are available upon request.

Belt material	Pin material	Belt performance [N/m]	Range di temperature [°C]	Weight [kg/m²]
PP	PP	13800	+5 ÷ +90	5,6
PE	PE	12100	-73 ÷ +66	5,8
POM	PA	26700	-40 ÷ +80	7,9
POM	PP	22000	+5 ÷ +70	7,9

PP = Polypropylene - PE = Polyethylene - POM = Acetal Resin - PA = Polyamide

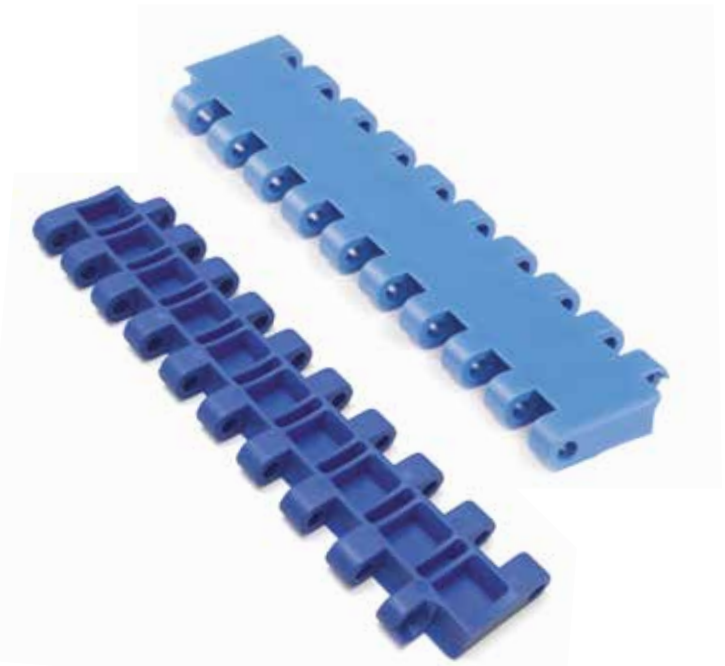

Belt width [W]

Minimum [mm]	Standard increment [mm]	Special increment [mm]	Width tolerance* [mm]
152,4	Multiple: 76,2	Multiple: 15,24	+/-2 up to 300
			+/-3 up to 600
			+/-4 more than 600

*It is advisable to consider dimensional variations in width based on operating temperatures and humidity when the belt is made of polyamide.

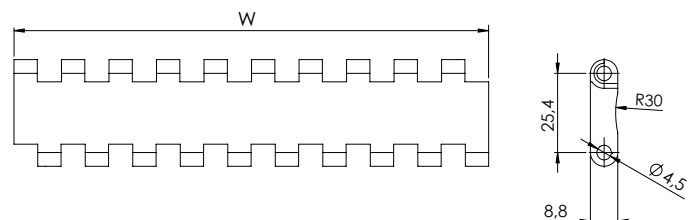

Part number	NMXP 254 C -PP -W
Type	Belt color: W = white / B = blue Belt material: PO = POM - Acetal Resin / PP = Polypropylene PE = Polyethylene / PA = Polyamide
Pitch	
Closed flat top surface	

NMXP254CL

PITCH 25,4 mm / 1"

STRAIGHT MODULAR BELTS

- Belt type:** closed flat top surface
- Pin diameter:** Ø 4,5 mm
- Open area:** 0%
- Hole openings:** -
- Minimum width:** 152,4 mm
- Thickness:** 8,8 mm
- Accessories:** flights - side wall



Standard executions

Belt material	Belt color	Pin
POM	Blue / yellow	PA

Other materials and colors are available upon request.

Belt material	Pin material	Belt performance [N/m]	Range di temperature [°C]	Weight [kg/m ²]
PP	PP	14700	+5 ÷ +90	5,6
PE	PE	12900	-73 ÷ +66	5,8
POM	PA	28400	-40 ÷ +80	7,9
POM	PP	23400	+5 ÷ +70	7,9

PP = Polypropylene - PE = Polyethylene - POM = Acetal Resin - PA = Polyamide

Belt width [W]

Minimum [mm]	Standard increment [mm]	Special increment [mm]	Width tolerance* [mm]
152,4	Multiple: 76,2	-	+/-2 up to 300
			+/-3 up to 600
			+/-4 more than 600

*It is advisable to consider dimensional variations in width based on operating temperatures and humidity when the belt is made of polyamide.

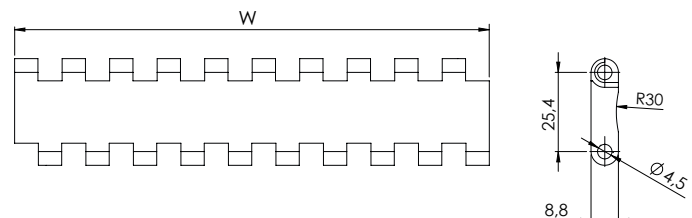

Part number

NMXP 254 CL -PP -W

Type

Pitch

Closed flat top surface

Belt color: B = blue / Y = yellow

Belt material:
PO = POM - Acetal Resin / PP = Polypropylene
PE = Polyethylene / PA = Polyamide

PITCH 25,4 mm / 1"

- Belt type:** no slip closed surface
- Pin diameter:** \varnothing 4,5 mm
- Open area:** 0%
- Hole openings:** -
- Minimum width:** 152,4 mm
- Thickness:** 8,8+0,5 mm
- Accessories:** flights - side wall



Standard executions

Belt material	Belt color	Pin
POM	Blue / yellow	PA

Other materials and colors are available upon request.

Belt material	Pin material	Belt performance [N/m]	Range di temperature [°C]	Weight [kg/m ²]
PP	PP	14700	+5 ÷ +90	5,7
PE	PE	12900	-73 ÷ +66	5,9
POM	PA	28400	-40 ÷ +80	8,0
POM	PP	23400	+5 ÷ +70	8,0

PP = Polypropylene - PE = Polyethylene - POM = Acetal Resin - PA = Polyamide

Belt width [W]

Minimum [mm]	Standard increment [mm]	Special increment [mm]	Width tolerance* [mm]
152,4	Multiple: 76,2	-	+/-2 up to 300
			+/-3 up to 600
			+/-4 more than 600

*It is advisable to consider dimensional variations in width based on operating temperatures and humidity when the belt is made of polyamide.

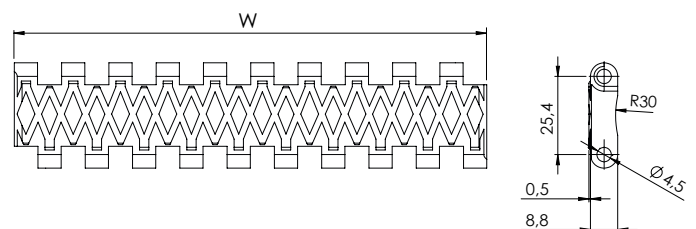

Part number	NMXP 254 CR -PO -B	
Type	No slip closed surface	
Pitch	25,4 mm	
Belt color:	B = blue / Y = yellow	
Belt material:	PO = POM - Acetal Resin / PP = Polypropylene PE = Polyethylene / PA = Polyamide	

Accessories for XP254 type

Flights

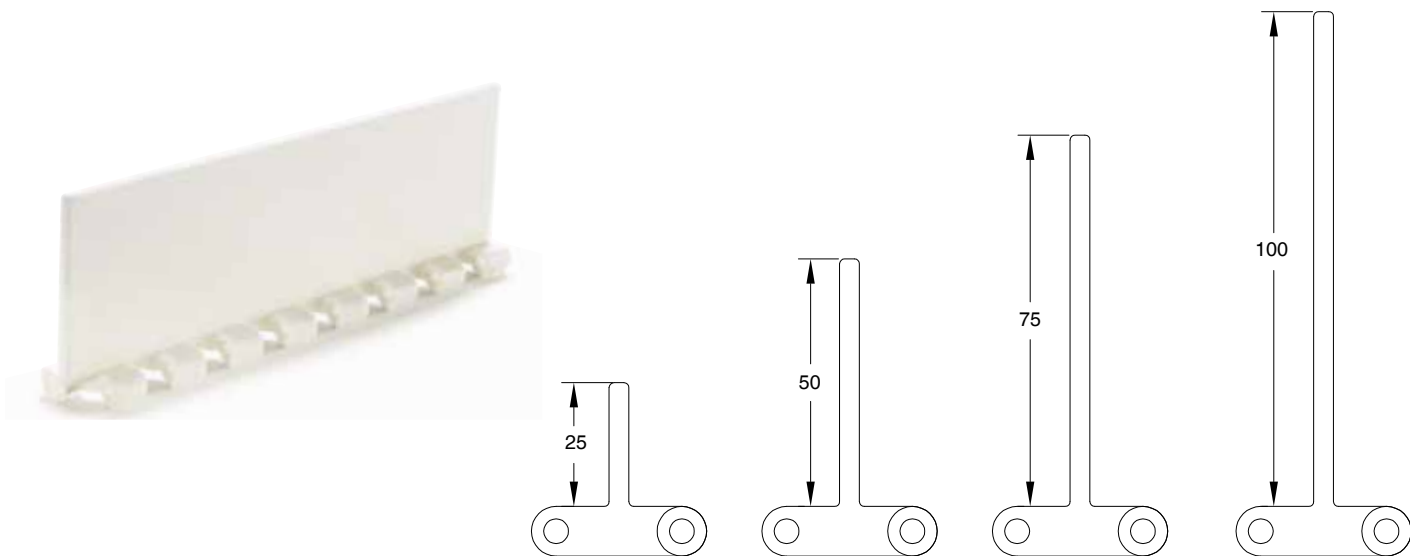

In case of need of flights the following table shows the standard indent. it is possible to have a special indent according to specific customer request.



Standard indent [mm]	Z	30,4	45,6	60,8
----------------------	---	------	------	------

In the case of wide belts, one or more gaps is recommended between flights to allow the belt to be supported on the return path. The maximum width not supported by guides depends on several factors such as the load on the belt, possible incline of the conveyor, and belt or pin material.

Side wall

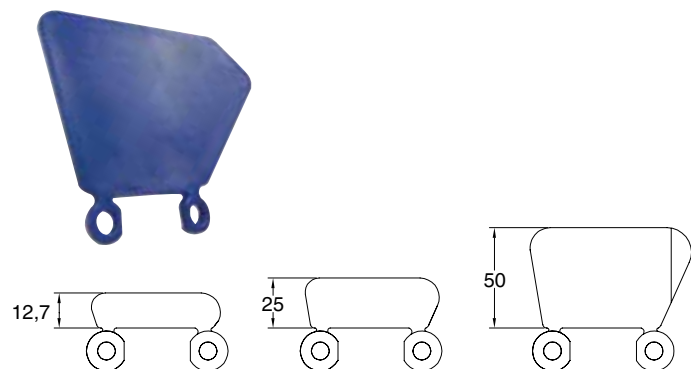

Inner and outer side wall indent [mm]	Y _i	16	23	30	38	46	53
	Y _e	26	33	40	48	56	63

Sprockets for XP254 type



Teeth nr.	Dp [mm]	Do [mm]	A [mm]	B [mm]	Available standard bore	
					Square [mm]	Ø round + set-screw UNI
10	82,2	81	25	8	40x40	25 - 30
12	98,1	97	25	8	40x40	25 - 30
15	122,2	122	25	8	40x40 - 60x60	25 - 30
18	146,3	146	25	8	40x40 - 60x60	25 - 30

Standard material: nylon PA6 fiberglass.
 It is possible to supply sprocket with any number of teeth or any material by CNC machining
 Dp = Pitch diameter
 Do = External tooth diameter

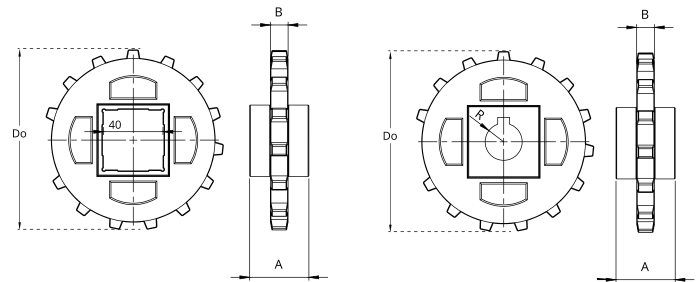

Part number **NSXP254** -Q 40 -Z12

Type _____

Bore type: R = round / Q = square _____

Bore dimension (mm) _____

Teeth nr. _____

Belt width [mm]			152,4	228,6	304,8	381,0	457,2	533,4	609,6	685,8	762,0	838,2	914,4	990,6	1066,8
Number of sprockes	Drive shaft	Belt tension ≤ 50% of the capacity	2	2	3	4	5	5	6	6	7	7	8	8	9
		Belt tension = 100% of the capacity	2	3	4	5	6	7	8	9	10	11	13	14	15
Driven shaft			2	2	2	3	3	3	3	4	4	4	4	5	5
Sliding guides			2	3	3	4	4	5	5	6	6	7	7	8	8

Belt width [mm]			1143	1219,2	1295,4	1371,6	1447,8	1524	1600,2	1676,4	1752,6	1828,8	1905	1981,2	2057,4
Number of sprockes	Drive shaft	Belt tension ≤ 50% of the capacity	9	10	10	11	11	12	12	12	13	14	14	15	15
		Belt tension = 100% of the capacity	16	17	18	19	20	21	22	23	25	26	27	28	29
Driven shaft			5	6	6	7	7	7	8	8	8	9	9	10	10
Sliding guides			9	9	10	10	11	11	12	12	13	13	14	14	15

Mounting

When mounting the sprockets, make sure that you have mounted all sprockets oriented in the same phase.
 Only axially lock the central sprocket and leave the other sprockets free to move axially.

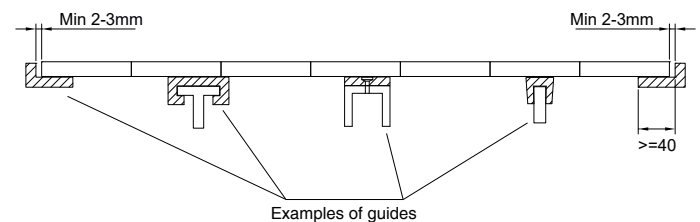

Sprockets for XP254 type

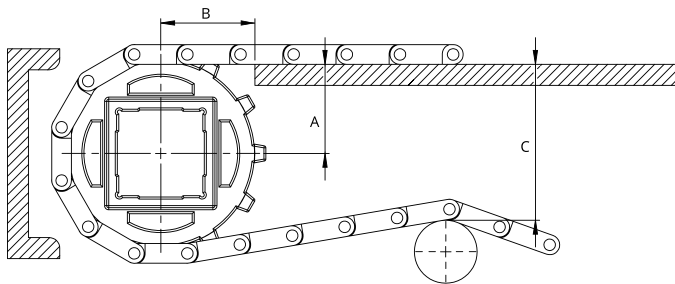

Teeth nr.	A _{max} [mm]	A _{min} [mm]	B1 [mm]	B2 [mm]	C _{max} [mm]
10	35,0	33,2	41	28	77
12	43,0	41,5	45	28	93
15	55,5	54,5	51	28	118
18	68,2	67,5	55	28	143

A_{max} = sliding surface position so that the height of the belt engaging the sprocket oscillates between the sliding surface height and a lower one. The height variation depends on the number of teeth and the pitch of the sprocket.

A_{min} = sliding surface position so that the height of the belt engaging the sprocket oscillates between the sliding surface height and a higher one. The height variation depends on the number of teeth and the pitch of the sprocket.

The choice of A dimensions depends on the items you have to carry. it is always suggested to make a chamfer at the end of the sliding guides.

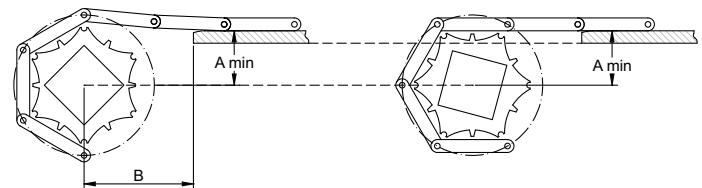
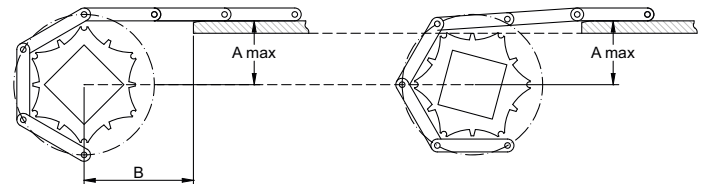

In order to avoid any subsidence of the belt in the area between the guiding strip and the sprockets, it is possible to locate the guides between the sprockets. Two minimum B1 and B2 dimensions are defined.

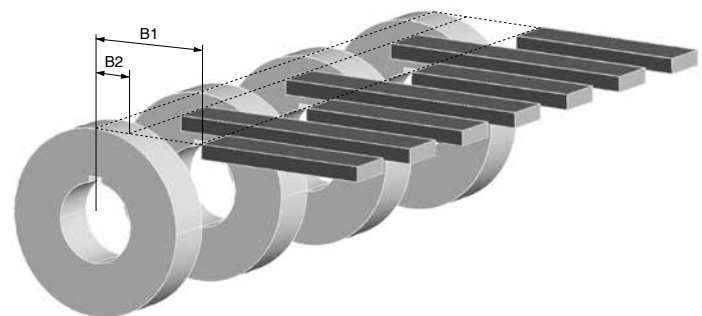

PITCH 25,4 mm / 1"

Belt type: closed flat top surface
Pin diameter: Ø 5 mm
Open area: 0%
Hole openings: -
Minimum width: 152,4 mm
Thickness: 10 mm
Accessories: flights - side wall
Food Certification: FDA - EU



Standard executions

Belt material	Belt color	Pin
PP	White - blue - gray	PP
PE	White - blue	POM
POM	White - blue	PA

Other materials and colors are available upon request.



Belt material	Pin material	Belt performance [N/m]	Temperature range [°C]	Certification	Weight [kg/m²]
PP	PP	14620	+5 ÷ +90	FDA - EU	6,9
PE	PE	13000	-73 ÷ +66	FDA - EU	7,1
POM	POM	26250	-43 ÷ +70	FDA - EU	9,9
POM	PA	28350	-40 ÷ +80	FDA - EU	9,7
POM	PP	23100	+5 ÷ +70	FDA - EU	9,7

PP = Polypropylene - PE = Polyethylene - POM = Acetal Resin - PA = Polyamide

Belt width [W]

Minimum [mm]	Standard increment [mm]	Special increment [mm]	Width tolerance* [mm]
152,4	Multiple: 76,2	Multiple: 15,24	+/-2 up to 300
			+/-3 up to 600
			+/-4 more than 600

*It is advisable to consider dimensional variations in width based on operating temperatures and humidity when the belt is made of polyamide.

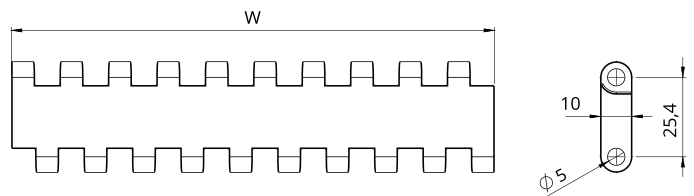

Part number	NMHP 254 C -PO -W	
Type	Belt color: W = white / B = blue / G = gray	
Pitch	Belt material: PO = POM - Acetal Resin / PP = Polypropylene PE = Polyethylene / PA = Polyamide	
Closed flat top surface		

NMHP254P22

PITCH 25,4 mm / 1"

STRAIGHT MODULAR BELTS

- Belt type:** flat perforated surface
- Pin diameter:** Ø 5 mm
- Open area:** 16%
- Hole openings:** 2,2x7,6 mm
- Minimum width:** 152,4 mm
- Thickness:** 10 mm
- Accessories:** flights - side wall
- Food Certification:** FDA - EU



Standard executions

Belt material	Belt color	Pin
PP	White - blue	PP
POM	White - blue	PA

Other materials and colors are available upon request.

Belt material	Pin material	Belt performance [N/m]	Temperature range [°C]	Certification	Weight [kg/m²]
PP	PP	13650	+5 ÷ +90	FDA - EU	6,6
PE	PE	11880	-73 ÷ +66	FDA - EU	6,9
POM	POM	25120	-43 ÷ +70	FDA - EU	9,2
POM	PA	27100	-40 ÷ +80	FDA - EU	9,0
POM	PP	22100	+5 ÷ +70	FDA - EU	9,0

PP = Polypropylene - PE = Polyethylene - POM = Acetal Resin - PA = Polyamide



Belt width [W]

Minimum [mm]	Standard increment [mm]	Special increment [mm]	Width tolerance* [mm]
152,4	Multiple: 76,2	Multiple: 15,24	+/-2 up to 300
			+/-3 up to 600
			+/-4 more than 600

*It is advisable to consider dimensional variations in width based on operating temperatures and humidity when the belt is made of polyamide.

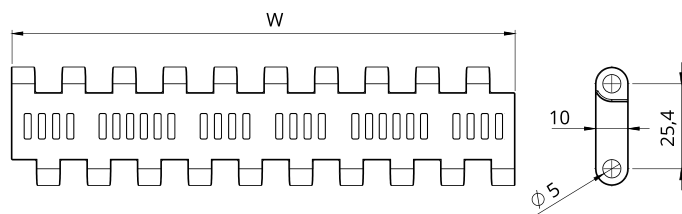

Part number

NMHP 254 P22 -PO -W

Type _____
 Pitch _____
 Flat perforated surface at 22%

Belt color: W = white / B = blue
 Belt material:
 PO = POM - Acetal Resin / PP = Polypropylene
 PE = Polyethylene / PA = Polyamide

PITCH 25,4 mm / 1"

Belt type: closed surface with rubber top insert
Pin diameter: Ø 5 mm
Open area: 0%
Insert: rubber 40 Sh
Minimum width: 152,4 mm
Thickness: 10+ 3mm
Accessories: flights - side wall



Standard executions

Belt material	Belt color	Rubber color	Pin
PP	White	White	PP
PE	Gray	Black	POM

Other materials and colors are available upon request.

Belt material	Pin material	Belt performance [N/m]	Temperature range [°C]	Certification	Weight [kg/m ²]
PP	PP	14620	+5 ÷ +50	-	7,1
PE	PE	13000	-10 ÷ +50	-	7,4

PP = Polypropylene - PE = Polyethylene - POM = Acetal Resin - PA = Polyamide



Belt width [W]

Minimum [mm]	Standard increment [mm]	Special increment [mm]	Width tolerance* [mm]
152,4	Multiple: 76,2	Multiple: 15,24	+/-2 up to 300
			+/-3 up to 600
			+/-4 more than 600

*It is advisable to consider dimensional variations in width based on operating temperatures and humidity when the belt is made of polyamide.

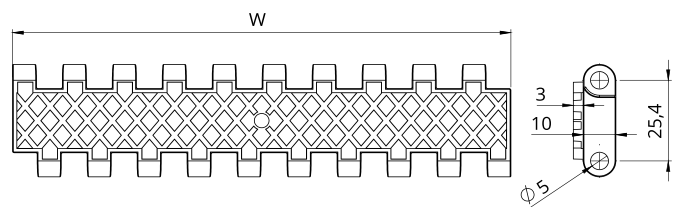

Part number	NMHP 254 GT -PO -W	
Type	Belt color: W = white / G = gray	
Pitch	Belt material: PO = POM - Acetal Resin / PP = Polypropylene PE = Polyethylene	
Closed surface with rubber top insert		

NMHP254RR

PITCH 25,4 mm / 1"

STRAIGHT MODULAR BELTS

- Belt type:** open flat surface rised rib
- Pin diameter:** Ø 5 mm
- Open area:** 16%
- Surface contact with the product:** 40%
- Minimum width:** 152,4 mm
- Thickness:** 15,7 mm
- Accessories:** loading and unloading comb
- Food Certification:** FDA - EU



Standard executions

Belt material	Belt color	Pin
PP	White - blue	PP
POM	White - blue	PA

Other materials and colors are available upon request.

Belt material	Pin material	Belt performance [N/m]	Temperature range [°C]	Certification	Weight [kg/m ²]
PP	PP	14620	+5 ÷ +90	FDA - EU	7,3
PE	PE	13000	-73 ÷ +66	FDA - EU	7,6
POM	POM	25300	-43 ÷ +70	FDA - EU	10,3
POM	PA	27300	-40 ÷ +80	FDA - EU	10,1
POM	PP	22250	+5 ÷ +70	FDA - EU	10,1

PP = Polypropylene - PE = Polyethylene - POM = Acetal Resin - PA = Polyamide



Belt width [W]

Minimum [mm]	Standard increment [mm]	Special increment [mm]	Width tolerance* [mm]
152,4	Multiple: 76,2	Multiple: 15,24	+/-2 up to 300
			+/-3 up to 600
			+/-4 more than 600

*It is advisable to consider dimensional variations in width based on operating temperatures and humidity when the belt is made of polyamide.

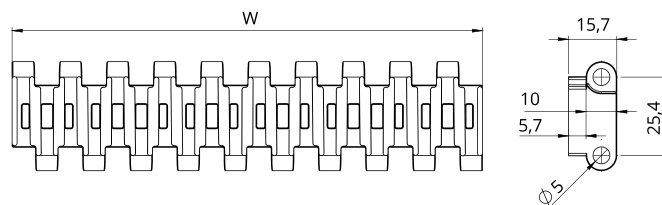

Part number

NMHP 254 RR -PO -W

Type _____

Pitch _____

Open flat surface rised rib _____

Belt color: W = white / B = blue

Belt material:
 PO = POM - Acetal Resin / PP = Polypropylene
 PE = Polyethylene / PA = Polyamide

Accessories for NMHP254 type

Flights

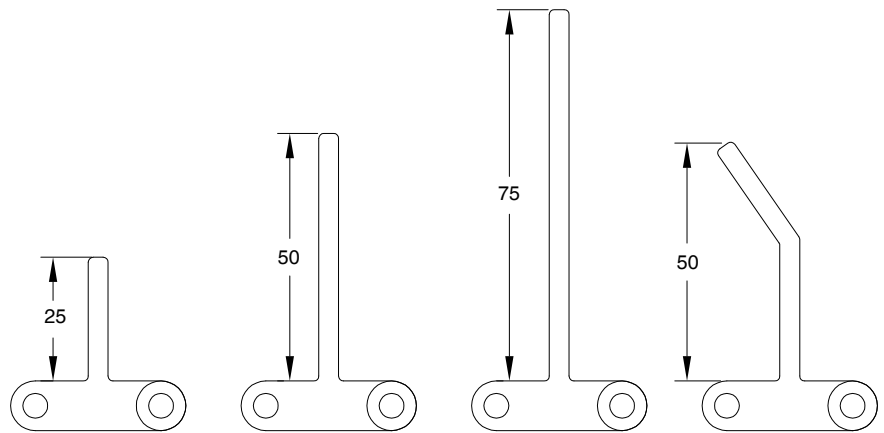

In case of need of flights the following table shows the standard indent. it is possible to have a special indent according to specific customer request.



Standard indent [mm]	Z	30,4	45,6	60,8

In the case of wide belts, one or more gaps is recommended between flights to allow the belt to be supported on the return path. The maximum width not supported by guides depends on several factors such as the load on the belt, possible incline of the conveyor, and belt or pin material.

Side wall

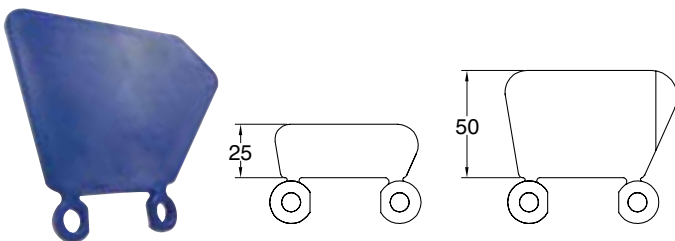

Inner and outer side wall indent [mm]	Y _i	16	23	30	38	46	53
	Y _e	26	33	40	48	56	63

Comb for NMHP254RR type

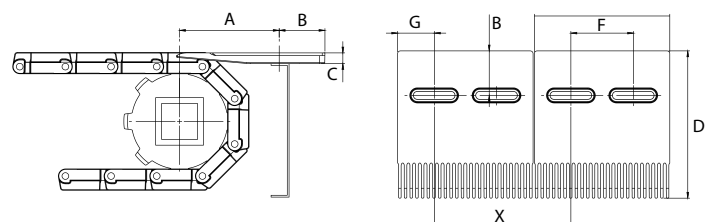

Quote [mm]	A	B	C	D	E	F	G	X
	105-115	25	12,5	146	150	75	37,5	155

Sprockets for HP254 type

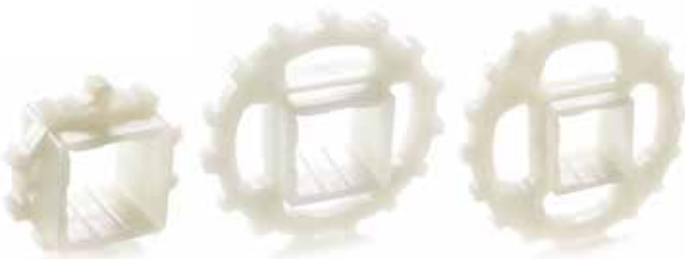

Teeth nr.	Dp [mm]	Do [mm]	A [mm]	B [mm]	Available standard bore	
					Square [mm]	Ø round + set-screw UNI
8	67,4	64,0	40	12	25x25	25 - 30
10	83,5	82,5	40	12	40x40	25 - 30
12	99,7	99,5	40	12	40x40	25 - 30
15	124,1	124,0	40	12	40x40	25 - 30
18	148,6	149,5	40	12	40x40	25 - 30

Standard material: nylon PA6 fiberglass.
It is possible to supply sprocket with any number of teeth or any material by CNC machining

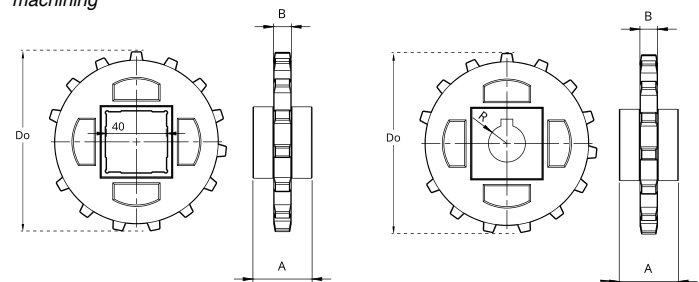

Part number NSHP254 -Q 40 -Z15

Type _____

Bore type: R = round / Q = square _____

Bore dimension (mm) _____

Teeth nr. _____

Belt width [mm]			152,4	228,6	304,8	381,0	457,2	533,4	609,6	685,8	762,0	838,2	914,4	990,6	1066,8
Number of sprockes	Drive shaft	Belt tension ≤ 50% of the capacity	2	2	3	4	5	5	6	6	7	7	8	8	9
		Belt tension = 100% of the capacity	2	3	4	5	6	7	8	9	10	11	13	14	15
Driven shaft			2	2	2	3	3	3	3	4	4	4	4	5	5
Sliding guides			2	3	3	4	4	5	5	6	6	7	7	8	8

Belt width [mm]			1143	1219,2	1295,4	1371,6	1447,8	1524	1600,2	1676,4	1752,6	1828,8	1905	1981,2	2057,4
Number of sprockes	Drive shaft	Belt tension ≤ 50% of the capacity	9	10	10	11	11	12	12	12	13	14	14	15	15
		Belt tension = 100% of the capacity	16	17	18	19	20	21	22	23	25	26	27	28	29
Driven shaft			5	6	6	7	7	7	8	8	8	9	9	10	10
Sliding guides			9	9	10	10	11	11	12	12	13	13	14	14	15

Mounting

When mounting the sprockets, make sure that you have mounted all sprockets oriented in the same phase.
Only axially lock the central sprocket and leave the other sprockets free to move axially.

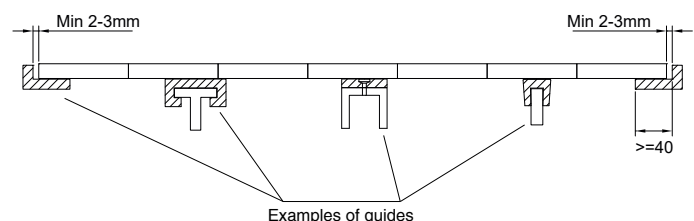

Sprockets for HP254 type

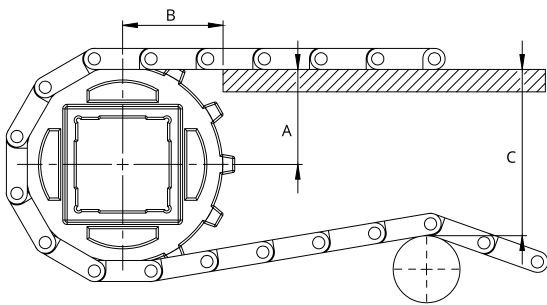

Teeth nr.	A _{max} [mm]	A _{min} [mm]	B1 [mm]	B2 [mm]	C _{max} [mm]
8	28,0	26,0	39	28	58
10	36,8	35,0	41	28	77
12	45,0	43,5	45	28	93
15	57,0	56,0	51	28	118
18	69,0	68,3	55	28	143

A_{max} = sliding surface position so that the height of the belt engaging the sprocket oscillates between the sliding surface height and a lower one. The height variation depends on the number of teeth and the pitch of the sprocket.

A_{min} = sliding surface position so that the height of the belt engaging the sprocket oscillates between the sliding surface height and a higher one. The height variation depends on the number of teeth and the pitch of the sprocket.

The choice of A dimensions depends on the items you have to carry. it is always suggested to make a chamfer at the end of the sliding guides.

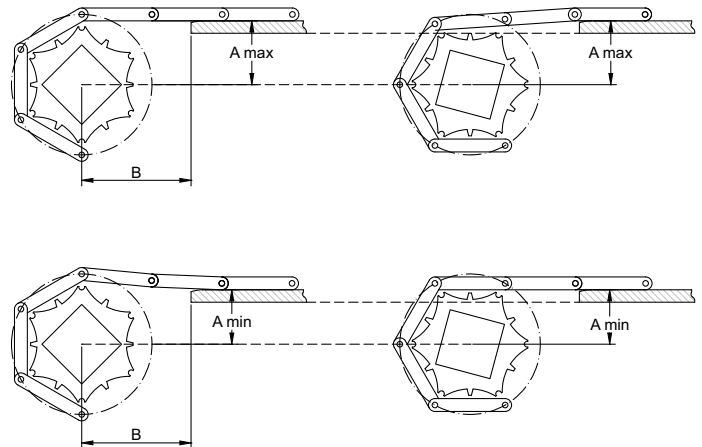

In order to avoid any subsidence of the belt in the area between the guiding strip and the sprockets, it is possible to locate the guides between the sprockets. Two minimum B1 and B2 dimensions are defined.

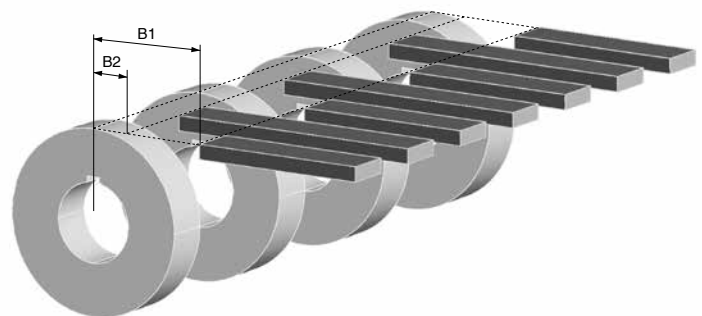

NMEC381C

STRAIGHT MODULAR BELTS

PITCH 38,1 mm / 1,5"

- Belt type:** closed flat top surface
- Pin diameter:** Ø 5,7 mm
- Open area:** 0%
- Hole openings:** -
- Minimum width:** 152,4 mm
- Thickness:** 12,5 mm
- Accessories:** flights - side wall
- Food Certification:** FDA - EU



Standard executions

Belt material	Belt color	Pin
PP	White - blue	PP
PE	White - blue	POM
POM	White - blue	PA

Other materials and colors are available upon request.

Belt material	Pin material	Belt performance [N/m]	Temperature range [°C]	Certification	Weight [kg/m ²]
PP	PP	15900	+5 ÷ +90	FDA - EU	6,35
PE	PE	15200	-73 ÷ +66	FDA - EU	6,60
POM	POM	26950	-43 ÷ +70	FDA - EU	9,60
POM	PA	29100	-40 ÷ +80	FDA - EU	9,30
POM	PP	24200	+5 ÷ +70	FDA - EU	9,30

PP = Polypropylene - PE = Polyethylene - POM = Acetal Resin - PA = Polyamide



Belt width [W]

Minimum [mm]	Standard increment [mm]	Special increment [mm]	Width tolerance* [mm]
152,4	Multiple: 76,2	Multiple: 15,24	+/-2 up to 300
			+/-3 up to 600
			+/-4 more than 600

*It is advisable to consider dimensional variations in width based on operating temperatures and humidity when the belt is made of polyamide.

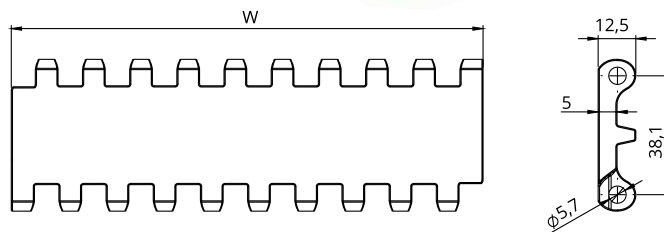

Part number

NMEC 381 C -PO -W

Type _____

Pitch _____

Closed flat top surface _____

Belt color: W = white / B = blue

Belt material:
 PO = POM - Acetal Resin / PP = Polypropylene
 PE = Polyethylene / PA = Polyamide

PITCH 38,1 mm / 1,5"

Belt type: open flat surface
Pin diameter: Ø 5,7 mm
Open area: 22%
Hole openings: 2,5x8 mm
Minimum width: 152,4 mm
Thickness: 12,5 mm
Accessories: flights - side wall
Food Certification: FDA - EU



Standard executions

Belt material	Belt color	Pin
PP	White - blue	PP
PE	White - blue	POM
POM	White - blue	PA

Other materials and colors are available upon request.

Belt material	Pin material	Belt performance [N/m]	Temperature range [°C]	Certification	Weight [kg/m²]
PP	PP	15270	+5 ÷ +90	FDA - EU	5,7
PE	PE	13970	-73 ÷ +66	FDA - EU	5,9
POM	POM	26900	-43 ÷ +70	FDA - EU	8,6
POM	PA	29000	-40 ÷ +80	FDA - EU	8,3
POM	PP	23650	+5 ÷ +70	FDA - EU	8,3

PP = Polypropylene - PE = Polyethylene - POM = Acetal Resin - PA = Polyamide



Belt width [W]

Minimum [mm]	Standard increment [mm]	Special increment [mm]	Width tolerance* [mm]
152,4	Multiple: 76,2	Multiple: 15,24	+/-2 up to 300
			+/-3 up to 600
			+/-4 more than 600

*It is advisable to consider dimensional variations in width based on operating temperatures and humidity when the belt is made of polyamide.

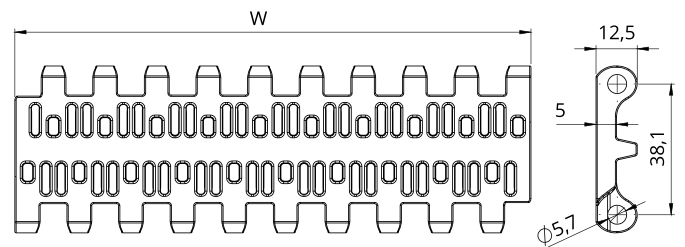

Part number	NMEC 381 P22 -PO -W	
Type	Belt color: W = white / B = blue	
Pitch	Belt material: PO = POM - Acetal Resin / PP = Polypropylene PE = Polyethylene / PA = Polyamide	
Open flat surface		

NMEC381FG

PITCH 38,1 mm / 1,5"

STRAIGHT MODULAR BELTS

- Belt type:** open flat surface flush grid
- Pin diameter:** Ø 5,7 mm
- Open area:** 30%
- Hole openings:** 6,5x11 mm
- Minimum width:** 152,4 mm
- Thickness:** 12,5 mm
- Accessories:** flights - side wall
- Food Certification:** FDA - EU



Standard executions

Belt material	Belt color	Pin
PP	White - blue	PP
PE	White - blue	POM
POM	White - blue	PA

Other materials and colors are available upon request.

Belt material	Pin material	Belt performance [N/m]	Temperature range [°C]	Certification	Weight [kg/m²]
PP	PP	14900	+5 ÷ +90	FDA - EU	5,3
PE	PE	14300	-73 ÷ +66	FDA - EU	5,4
POM	POM	24800	-43 ÷ +70	FDA - EU	8,0
POM	PA	26850	-40 ÷ +80	FDA - EU	7,7
POM	PP	21850	+5 ÷ +70	FDA - EU	7,7

PP = Polypropylene - PE = Polyethylene - POM = Acetal Resin - PA = Polyamide



Belt width [W]

Minimum [mm]	Standard increment [mm]	Special increment [mm]	Width tolerance* [mm]
152,4	Multiple: 76,2	Multiple: 15,24	+/-2 up to 300
			+/-3 up to 600
			+/-4 more than 600

*It is advisable to consider dimensional variations in width based on operating temperatures and humidity when the belt is made of polyamide.

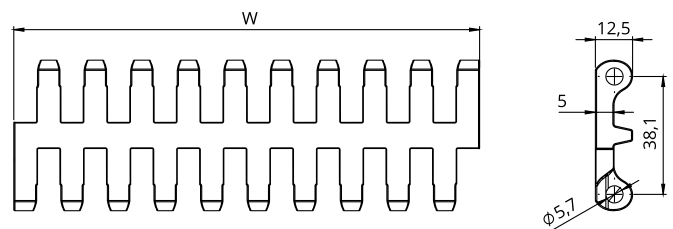

Part number

NMEC 381 FG -PO -W

Type _____
 Pitch _____
 Open flat surface flush grid

Belt color: W = white / B = blue
 Belt material:
 PO = POM - Acetal Resin / PP = Polypropylene
 PE = Polyethylene / PA = Polyamide

PITCH 38,1 mm / 1,5"

Belt type: closed surface nub top pattern

Pin diameter: Ø 5,7 mm

Open area: 0%

Hole openings: -

Minimum width: 152,4 mm

Thickness: 14,5 mm

Accessories: flights - side wall

Food Certification: FDA - EU



Standard executions

Belt material	Belt color	Pin
PP	White - blue	PP
PE	White - blue	POM
POM	White - blue	PA

Other materials and colors are available upon request.



Belt material	Pin material	Belt performance [N/m]	Temperature range [°C]	Certification	Weight [kg/m²]
PP	PP	15900	+5 ÷ +90	FDA - EU	6,50
PE	PE	15200	-73 ÷ +66	FDA - EU	6,85
POM	POM	26950	-43 ÷ +70	FDA - EU	9,90
POM	PA	29100	-40 ÷ +80	FDA - EU	9,60
POM	PP	24200	+5 ÷ +70	FDA - EU	9,60

PP = Polypropylene - PE = Polyethylene - POM = Acetal Resin - PA = Polyamide

Belt width [W]

Minimum [mm]	Standard increment [mm]	Special increment [mm]	Width tolerance* [mm]
152,4	Multiple: 76,2	Multiple: 15,24	+/-2 up to 300
			+/-3 up to 600
			+/-4 more than 600

*It is advisable to consider dimensional variations in width based on operating temperatures and humidity when the belt is made of polyamide.

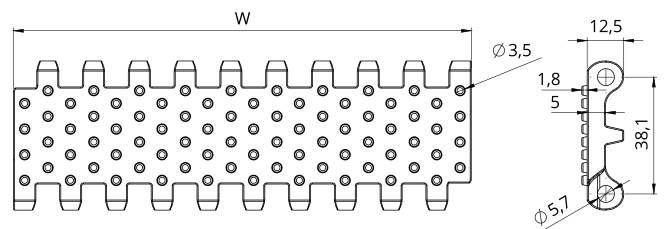

Part number	NMEC 381 NT -PO -W	
Type	Belt color: W = white / B = blue	
Pitch	Belt material: PO = POM - Acetal Resin / PP = Polypropylene PE = Polyethylene / PA = Polyamide	
Closed surface nub top pattern		

Accessories for EC381 type

Flights

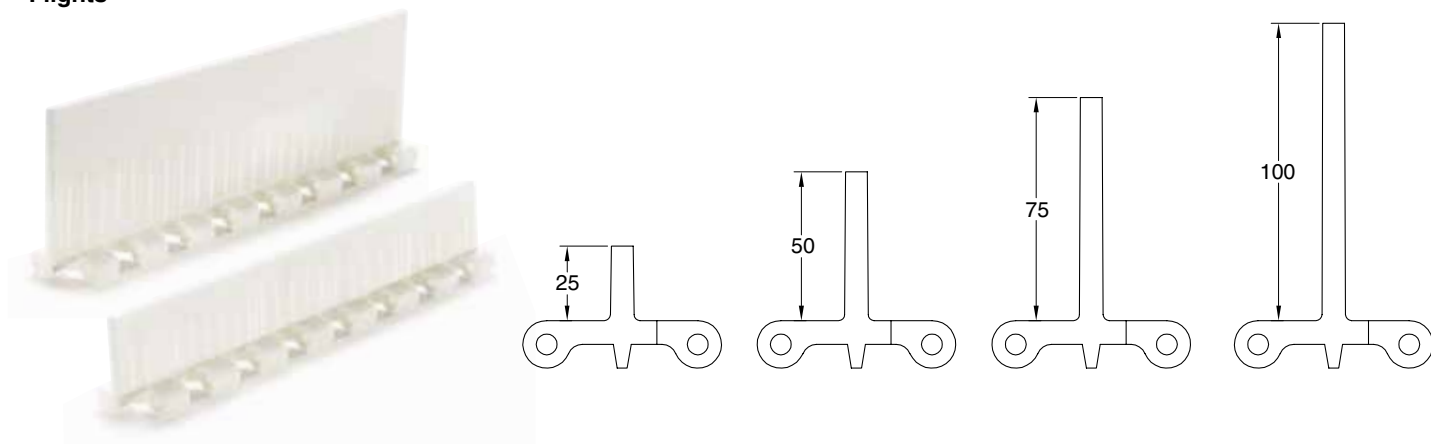

In case of need of flights the following table shows the standard indent. it is possible to have a special indent according to specific customer request.



Standard indent [mm]	Z	15,2	30,4	45,6	60,8

In the case of wide belts, one or more gaps is recommended between flights to allow the belt to be supported on the return path. The maximum width not supported by guides depends on several factors such as the load on the belt, possible incline of the conveyor, and belt or pin material.

Side wall

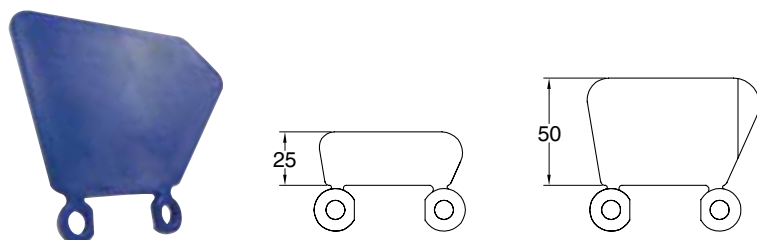

Inner and outer side wall indent [mm]	Y _i	16	23	30	38	46	53
	Y _e	26	33	40	48	56	63

Sprockets for EC381 type



Teeth nr.	Dp [mm]	Do [mm]	A [mm]	B [mm]	Available standard bore	
					Square [mm]	Ø round + set-screw UNI
8	99,6	97,6	40	10	40x40	20 - 25 - 30
10	123,3	122,0	40	10	40x40	20 - 25 - 30
12	147,2	146,4	40	10	40x40	20 - 25 - 30

Materiale standard: nylon PA6 caricato fibra di vetro.
 È possibile realizzare da macchina utensile pignoni con numero di denti e materiali diversi.

Part number NSEC381 -Q 40 -Z10

Type _____

Bore type: R = round / Q = square _____

Bore dimension (mm) _____

Teeth nr. _____

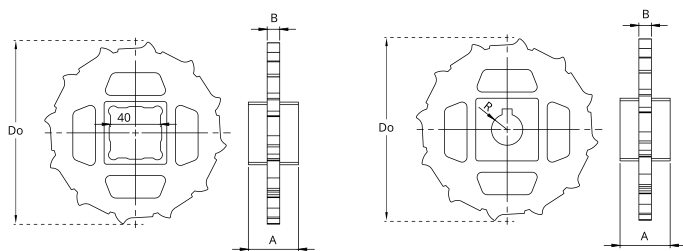

Belt width [mm]		152,4	228,6	304,8	381,0	457,2	533,4	609,6	685,8	762,0	838,2	914,4	990,6	1066,8		
Number of sprockes	Drive shaft	Belt tension ≤ 50% of the capacity		2	2	3	4	5	5	6	6	7	7	8	8	9
	Belt tension = 100% of the capacity		2	2	3	4	5	6	7	8	9	10	11	12	13	
Driven shaft		2	2	2	3	3	3	3	4	4	4	4	5	5		
Sliding guides		2	3	3	3	4	4	5	5	5	6	6	6	7		

Belt width [mm]		1143,0	1219,2	1295,4	1371,6	1447,8	1524,0	1600,2	1676,4	1752,6	1828,8	1905,0	1981,2	2057,4		
Number of sprockes	Drive shaft	Belt tension ≤ 50% of the capacity		9	10	10	11	11	12	12	12	13	14	14	15	15
	Belt tension = 100% of the capacity		14	15	16	17	18	19	20	20	21	22	23	24	25	
Driven shaft		5	6	6	7	7	7	8	8	8	9	9	10	10		
Sliding guides		7	8	8	8	9	9	10	10	10	11	11	11	12		

Mounting

When mounting the sprockets, make sure that you have mounted all sprockets oriented in the same phase.
 Only axially lock the central sprocket and leave the other sprockets free to move axially.

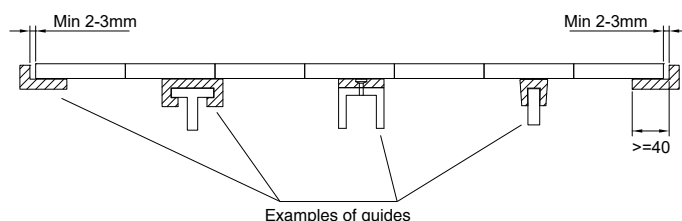

Sprockets for EC381 type

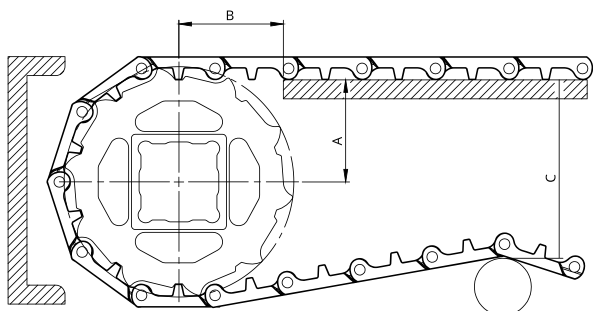

Teeth nr.	A _{max} [mm]	A _{min} [mm]	B1 [mm]	B2 [mm]	C _{max} [mm]
8	44,0	41,0	49	42	91
10	55,5	54,0	55	42	116
12	67,5	66,5	59	42	140

A_{max} = sliding surface position so that the height of the belt engaging the sprocket oscillates between the sliding surface height and a lower one. The height variation depends on the number of teeth and the pitch of the sprocket.

A_{min} = sliding surface position so that the height of the belt engaging the sprocket oscillates between the sliding surface height and a higher one. The height variation depends on the number of teeth and the pitch of the sprocket.

The choice of A dimensions depends on the items you have to carry. it is always suggested to make a chamfer at the end of the sliding guides.

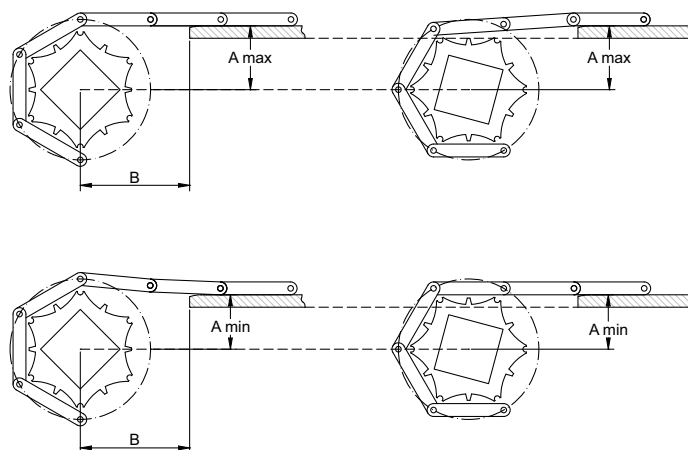

In order to avoid any subsidence of the belt in the area between the guiding strip and the sprockets, it is possible to locate the guides between the sprockets. Two minimum B1 and B2 dimensions are defined.

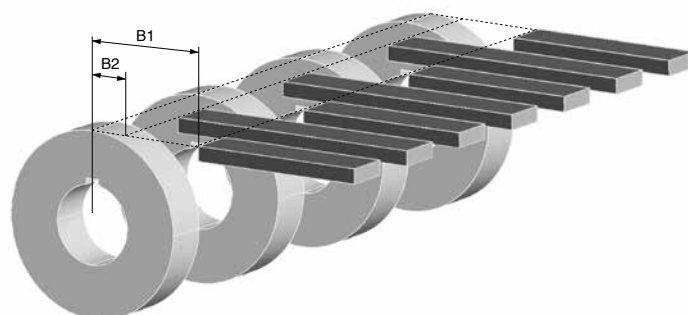

STRAIGHT MODULAR BELTS

PITCH 50,8 mm / 2"

Belt type: closed flat top surface
Pin diameter: Ø 7 mm
Open area: 0%
Hole openings: -
Minimum width: 200 mm
Thickness: 16 mm
Accessories: flights - side wall
Food Certification: FDA - EU



Standard executions

Belt material	Belt color	Pin
PP	White - blue	PP
PE	White - blue	POM

Other materials and colors are available upon request.

Belt material	Pin material	Belt performance [N/m]	Temperature range [°C]	Certification	Weight [kg/m ²]
PP	PP	17500	+5 ÷ +90	FDA - EU	8,0
PE	PE	16750	-73 ÷ +66	FDA - EU	8,2
POM	POM	29500	-43 ÷ +70	FDA - EU	12,1
POM	PA	31500	-40 ÷ +80	FDA - EU	11,7
POM	PP	25650	+5 ÷ +70	FDA - EU	11,7

PP = Polypropylene - PE = Polyethylene - POM = Acetal Resin - PA = Polyamide



Belt width [W]

Minimum [mm]	Standard increment [mm]	Special increment [mm]	Width tolerance* [mm]
200	Multiple: 100	20	+/-2 up to 300
			+/-3 up to 600
			+/-4 more than 600

*It is advisable to consider dimensional variations in width based on operating temperatures and humidity when the belt is made of polyamide.

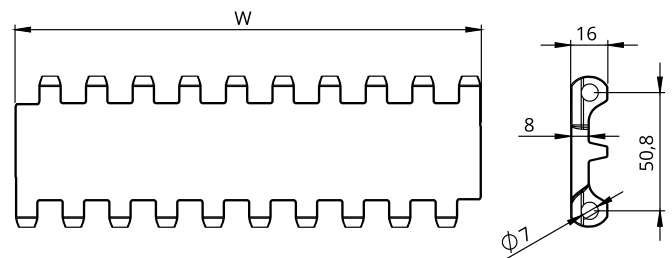

Part number	NMEC 508 C -PO -W	
Type	Belt color: W = white / B = blue	
Pitch	Belt material: PO = POM - Acetal Resin / PP = Polypropylene PE = Polyethylene / PA = Polyamide	
Closed flat top surface		

NMEC508P11

PITCH 50,8 mm / 2"

STRAIGHT MODULAR BELTS

- Belt type:** open flat surface
- Pin diameter:** \varnothing 7 mm
- Open area:** 11%
- Hole openings:** 1,2x12 mm
- Minimum width:** 200 mm
- Thickness:** 16 mm
- Accessories:** flights - side wall
- Food Certification:** FDA - EU

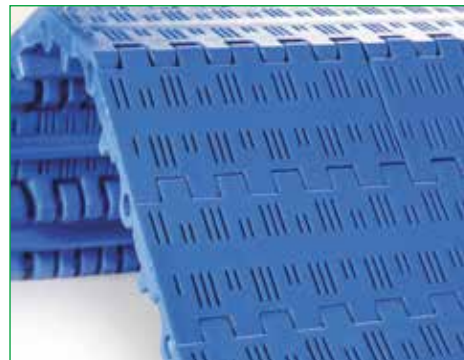

Standard executions

Belt material	Belt color	Pin
PP	White - blue	PP
POM	White - blue	PA

Other materials and colors are available upon request.

Belt material	Pin material	Belt performance [N/m]	Temperature range [°C]	Certification	Weight [kg/m ²]
PP	PP	16060	+5 ÷ +90	FDA - EU	6,9
PE	PE	15000	-73 ÷ +66	FDA - EU	7,2
POM	PA	30200	-40 ÷ +80	FDA - EU	10,2
POM	PP	24600	+5 ÷ +70	FDA - EU	10,2

PP = Polypropylene - PE = Polyethylene - POM = Acetal Resin - PA = Polyamide



Belt width [W]

Minimum [mm]	Standard increment [mm]	Special increment [mm]	Width tolerance* [mm]
200	Multiple: 100	20	+/-2 up to 300
			+/-3 up to 600
			+/-4 more than 600

*It is advisable to consider dimensional variations in width based on operating temperatures and humidity when the belt is made of polyamide.

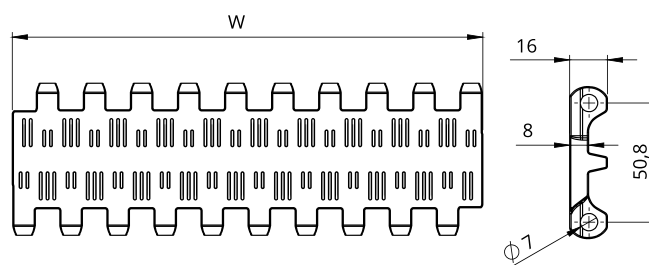

Part number

NMEC 508 P11 -PO -W

Type

Pitch

Open flat surface at 11%

Belt color: W = white / B = blue

Belt material:
PO = POM - Acetal Resin / PP = Polypropylene
PE = Polyethylene / PA = Polyamide

PITCH 50,8 mm / 2"

- Belt type:** flat perforated surface
- Pin diameter:** Ø 7 mm
- Open area:** 13%
- Hole openings:** Ø 4 mm
- Minimum width:** 200 mm
- Thickness:** 16 mm
- Accessories:** flights - side wall
- Food Certification:** FDA - EU



Standard executions

Belt material	Belt color	Pin
PP	White - blue	PP

Other materials and colors are available upon request.

Belt material	Pin material	Belt performance [N/m]	Temperature range [°C]	Certification	Weight [kg/m ²]
PP	PP	16060	+5 ÷ +90	FDA - EU	6,9
PE	PE	15000	-73 ÷ +66	FDA - EU	7,2
POM	POM	28400	-43 ÷ +70	FDA - EU	10,5
POM	PA	30200	-40 ÷ +80	FDA - EU	10,2
POM	PP	24600	+5 ÷ +70	FDA - EU	10,2

PP = Polypropylene - PE = Polyethylene - POM = Acetal Resin - PA = Polyamide



Belt width [W]

Minimum [mm]	Standard increment [mm]	Special increment [mm]	Width tolerance* [mm]
200	Multiple: 100	20	+/-2 up to 300
			+/-3 up to 600
			+/-4 more than 600

*It is advisable to consider dimensional variations in width based on operating temperatures and humidity when the belt is made of polyamide.

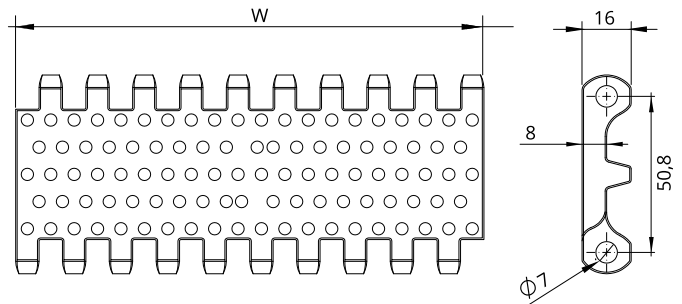

Part number	NMEC 508 P13 -PO -W	
Type		Belt color: W = white / B = blue
Pitch		Belt material: PO = POM - Acetal Resin / PP = Polypropylene PE = Polyethylene / PA = Polyamide
Flat perforated surface at 13%		

NMEC508P22

PITCH 50,8 mm / 2"

STRAIGHT MODULAR BELTS

- Belt type:** open flat surface
- Pin diameter:** Ø 7 mm
- Open area:** 22%
- Hole openings max.:** 3x12 mm
- Minimum width:** 200 mm
- Thickness:** 16 mm
- Accessories:** flights - side wall
- Food Certification:** FDA - EU



Standard executions

Belt material	Belt color	Pin
PP	White - blue	PP
PE	White - blue	POM
PPH	Blue	PPH

Other materials and colors are available upon request.

Belt material	Pin material	Belt performance [N/m]	Temperature range [°C]	Certification	Weight [kg/m ²]
PP	PP	16060	+5 ÷ +90	FDA - EU	6,9
PE	PE	15000	-73 ÷ +66	FDA - EU	7,2
POM	POM	28300	-43 ÷ +70	FDA - EU	10,5
POM	PA	30200	-40 ÷ +80	FDA - EU	10,2
POM	PP	24600	+5 ÷ +70	FDA - EU	10,2
PH	PH	16200	+20 ÷ +105	FDA - EU	6,9

PP = Polypropylene - PE = Polyethylene - POM = Acetal Resin - PA = Polyamide
 PPH = Polypropylene per alte temperature ambiente umido

Belt width [W]

Minimum [mm]	Standard increment [mm]	Special increment [mm]	Width tolerance* [mm]
200	Multiple: 100	20	+/-2 up to 300
			+/-3 up to 600
			+/-4 more than 600

*It is advisable to consider dimensional variations in width based on operating temperatures and humidity when the belt is made of polyamide.

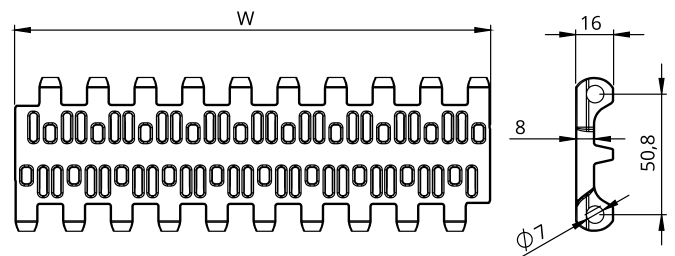

Part number

NMEC 508 P22 -PO -W

Type _____

PITCH _____

Open flat surface at 22% _____

Belt color: W = white / B = blue

Belt material:
 PO = POM - Acetal Resin / PP = Polypropylene
 PE = Polyethylene / PA = Polyamide / PH = Polypropylene high temperature

PITCH 50,8 mm / 2"

- Belt type:** open flat surface flush grid
- Pin diameter:** Ø 7 mm
- Open area:** 35%
- Hole openings:** 9x12 mm
- Minimum width:** 200 mm
- Thickness:** 16 mm
- Accessories:** flights - side wall
- Food Certification:** FDA - EU



Standard executions

Belt material	Belt color	Pin
PP	White - blue	PP
PE	White - blue	POM
POM	White - blue	PA

Other materials and colors are available upon request.



Belt material	Pin material	Belt performance [N/m]	Temperature range [°C]	Certification	Weight [kg/m²]
PP	PP	15050	+5 ÷ +90	FDA - EU	6,0
PE	PE	12100	-73 ÷ +66	FDA - EU	7,0
POM	POM	24900	-43 ÷ +70	FDA - EU	10,3
POM	PA	26600	-40 ÷ +80	FDA - EU	10,2
POM	PP	21600	+5 ÷ +70	FDA - EU	10,2

PP = Polypropylene - PE = Polyethylene - POM = Acetal Resin - PA = Polyamide

Belt width [W]

Minimum [mm]	Standard increment [mm]	Special increment [mm]	Width tolerance* [mm]
200	Multiple: 100	20	+/-2 up to 300
			+/-3 up to 600
			+/-4 more than 600

*It is advisable to consider dimensional variations in width based on operating temperatures and humidity when the belt is made of polyamide.

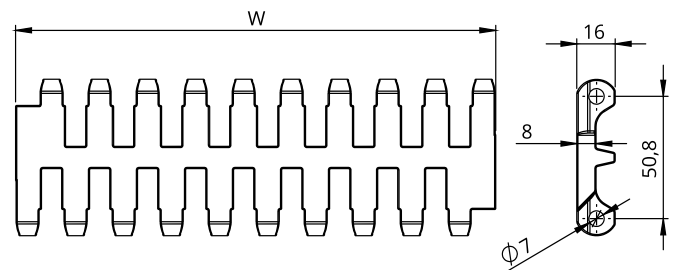

Part number

NMEC 508 FG -PO -W

Type _____
 Pitch _____
 Open flat surface flush grid

Belt color: W = white / B = blue

Belt material:
 PO = POM - Acetal Resin / PP = Polypropylene
 PE = Polyethylene / PA = Polyamide

NMEC508DT

PITCH 50,8 mm / 2"

STRAIGHT MODULAR BELTS

- Belt type:** closed surface with pyramid pattern
- Pin diameter:** Ø 7 mm
- Open area:** 0%
- Hole openings:** -
- Minimum width:** 200 mm
- Thickness:** 16+1 mm
- Accessories:** flights - side wall
- Food Certification:** FDA - EU

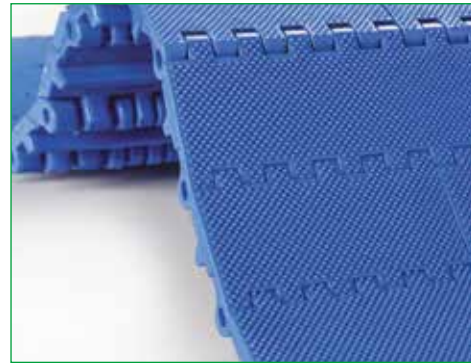

Standard executions

Belt material	Belt color	Pin
PP	White - blue	PP
PE	White - blue	POM
POM	White - blue	PA

Other materials and colors are available upon request.

Belt material	Pin material	Belt performance [N/m]	Temperature range [°C]	Certification	Weight [kg/m ²]
PP	PP	17500	+5 ÷ +90	FDA - EU	8,0
PE	PE	16750	-73 ÷ +66	FDA - EU	8,2
POM	POM	29500	-43 ÷ +70	FDA - EU	12,2
POM	PA	31500	-40 ÷ +80	FDA - EU	11,9
POM	PP	25650	+5 ÷ +70	FDA - EU	11,9

PP = Polypropylene - PE = Polyethylene - POM = Acetal Resin - PA = Polyamide

Belt width [W]

Minimum [mm]	Standard increment [mm]	Special increment [mm]	Width tolerance* [mm]
200	Multiple: 100	20	+/-2 up to 300
			+/-3 up to 600
			+/-4 more than 600

*It is advisable to consider dimensional variations in width based on operating temperatures and humidity when the belt is made of polyamide.

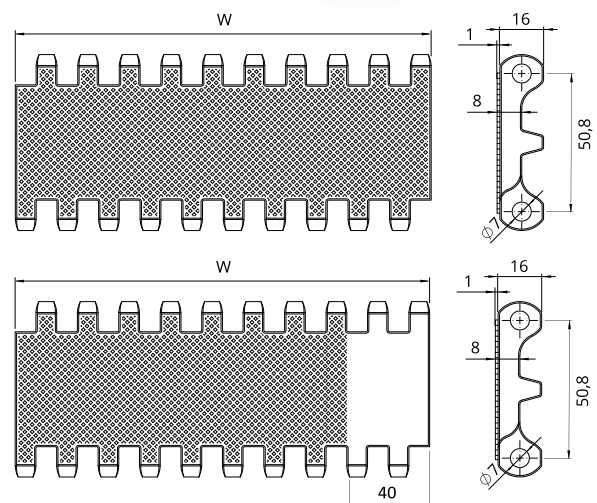
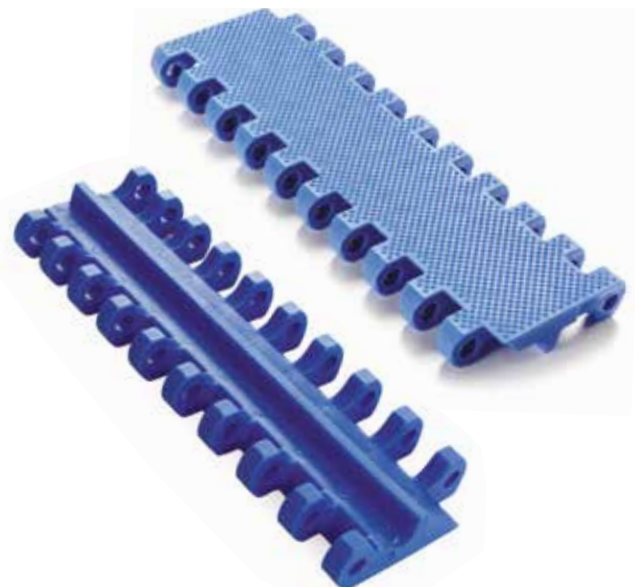

Part number

NMEC 508 DT -PO -W

Type _____

Pitch _____

Closed surface with pyramid pattern _____

Belt color: W = white / B = blue

Belt material:
 PO = POM - Acetal Resin / PP = Polypropylene
 PE = Polyethylene / PA = Polyamide

PITCH 50,8 mm / 2"

- Belt type:** closed surface with pyramid pattern - indent 40 mm
- Pin diameter:** \varnothing 7 mm
- Open area:** 0%
- Hole openings:** -
- Minimum width:** 200 mm
- Thickness:** 16+2,5 mm
- Accessories:** flights - side wall
- Food Certification:** FDA - EU



Standard executions

Belt material	Belt color	Pin
PP	White - blue	PP
PE	White - blue	POM

Other materials and colors are available upon request.

Belt material	Pin material	Belt performance [N/m]	Temperature range [°C]	Certification	Weight [kg/m ²]
PP	PP	17500	+5 ÷ +90	FDA - EU	8,2
PE	PE	16750	-73 ÷ +66	FDA - EU	8,4
POM	POM	29500	-43 ÷ +70	FDA - EU	12,3
POM	PA	31500	-40 ÷ +80	FDA - EU	11,9
POM	PP	26550	+5 ÷ +70	FDA - EU	11,9

PP = Polypropylene - PE = Polyethylene - POM = Acetal Resin - PA = Polyamide

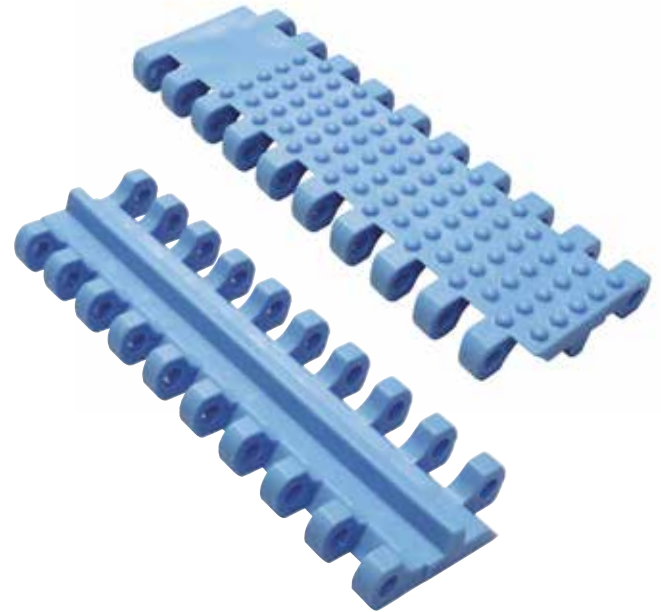

Belt width [W]

Minimum [mm]	Standard increment [mm]	Special increment [mm]	Width tolerance* [mm]
200	Multiple: 100	Multiple: 20	+/-2 up to 300
			+/-3 up to 600
			+/-4 more than 600

*It is advisable to consider dimensional variations in width based on operating temperatures and humidity when the belt is made of polyamide.

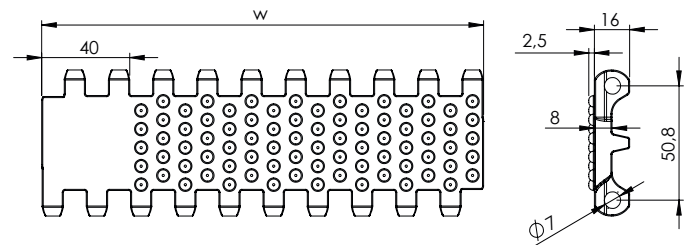

Part number	NMEC 508 NT -PO -W	
Type		Belt color: W = white / B = blue
Pitch		Belt material: PO = POM - Acetal Resin / PP = Polypropylene PE = Polyethylene / PA = Polyamide
Closed surface with pyramid pattern - indent 40 mm		

NMEC508FT

PITCH 50,8 mm / 2"

STRAIGHT MODULAR BELTS

- Belt type:** open surface with sferical - indetn 40 mm
- Pin diameter:** Ø 7 mm
- Open area:** 35%
- Hole openings:** 9x12 mm
- Minimum width:** 200 mm
- Thickness:** 16+2,5 mm
- Accessories:** flights - side wall
- Food Certification:** FDA - EU

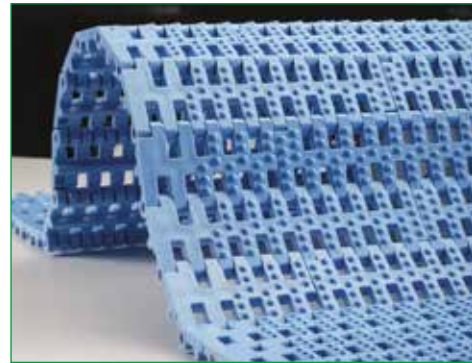

Standard executions

Belt material	Belt color	Pin
PP	White - blue	PP
PE	White - blue	POM

Other materials and colors are available upon request.

Belt material	Pin material	Belt performance [N/m]	Temperature range [°C]	Certification	Weight [kg/m ²]
PP	PP	15050	+5 ÷ +90	FDA - EU	6,2
PE	PE	12100	-73 ÷ +66	FDA - EU	7,2
POM	POM	24900	-43 ÷ +70	FDA - EU	10,5
POM	PA	26600	-40 ÷ +80	FDA - EU	10,4
POM	PP	21600	+5 ÷ +70	FDA - EU	10,4

PP = Polypropylene - PE = Polyethylene - POM = Acetal Resin - PA = Polyamide

Belt width [W]

Minimum [mm]	Standard increment [mm]	Special increment [mm]	Width tolerance* [mm]
200	Multiple: 50	Multiple: 16,7	+/-2 up to 300
			+/-3 up to 600
			+/-4 more than 600

*It is advisable to consider dimensional variations in width based on operating temperatures and humidity when the belt is made of polyamide.

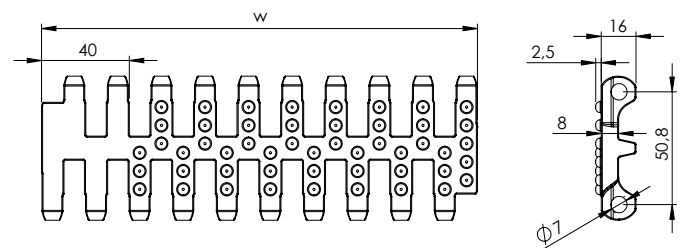

Part number

NMEC 508 FT -PO -W

Type _____
 Pitch _____
 Open surface with sferical - indetn 40 mm

Belt color: W = white / B = blue
 Belt material:
 PO = POM - Acetal Resin / PP = Polypropylene
 PE = Polyethylene / PA = Polyamide

Accessories for EC508 type

Flights

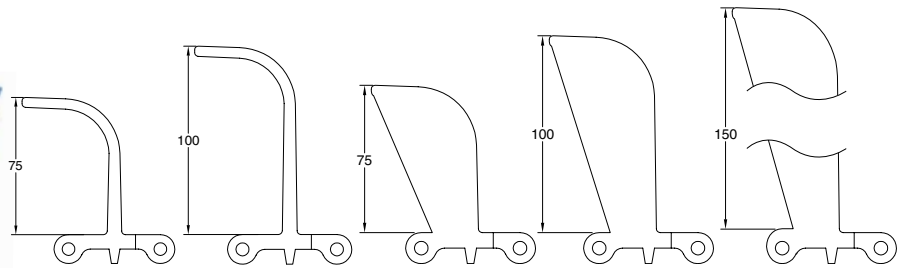

Heavy load design

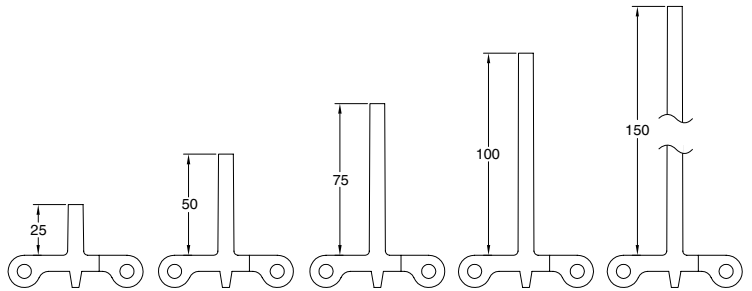

No cling execution

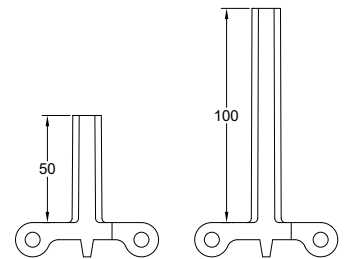

In case of need of flights the following table shows the standard indent. it is possible to have a special indent according to specific customer request.



Standard indent [mm]	Z	40	60	80	100

In the case of wide belts, one or more gaps is recommended between flights to allow the belt to be supported on the return path.

The maximum width not supported by guides depends on several factors such as the load on the belt, possible incline of the conveyor, and belt or pin material.

Side wall

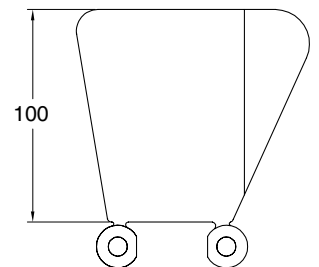
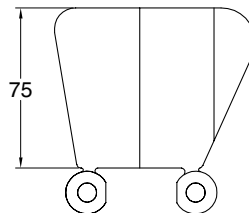
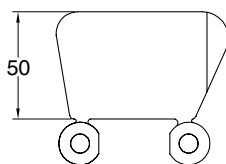
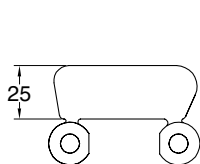

Inner and outer side wall indent [mm]	Y _i	20	30	40	50	60	70
	Y _e	32	42	52	62	72	82

Sprockets for EC508 type



Teeth nr.	Dp [mm]	Do [mm]	A [mm]	B [mm]	Available standard bore	
					Square [mm]	Ø round + set-screw UNI
6	101,6	88,5	40	31	40x40	20 - 25 - 30
8	132,7	122,4	40	31	40x40	20 - 25 - 30
10	164,4	156,5	40	31	40x40	20 - 25 - 30
12	196,3	189,7	40	31	40x40	20 - 25 - 30

Materiale standard: nylon PA6 caricato fibra di vetro.
È possibile realizzare da macchina utensile pignoni con numero di denti e materiali diversi.

Part number NSEC508 -R 30 -Z8

Type _____

Bore type: R = round / Q = square _____

Bore dimension (mm) _____

Teeth nr. _____

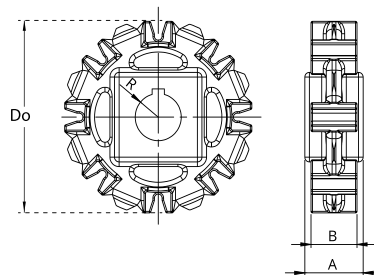

Belt width [mm]		200	300	400	500	600	700	800	900	1000	1100	1200	1400	1600																													
Number of sprockes	Drive shaft	<table border="1"> <tr> <td>Belt tension ≤ 50% of the capacity</td> <td>2</td><td>2</td><td>3</td><td>3</td><td>4</td><td>5</td><td>5</td><td>6</td><td>6</td><td>7</td><td>8</td><td>9</td><td>10</td> </tr> <tr> <td>Belt tension = 100% of the capacity</td> <td>2</td><td>3</td><td>5</td><td>6</td><td>7</td><td>8</td><td>10</td><td>11</td><td>12</td><td>13</td><td>15</td><td>17</td><td>20</td> </tr> </table>														Belt tension ≤ 50% of the capacity	2	2	3	3	4	5	5	6	6	7	8	9	10	Belt tension = 100% of the capacity	2	3	5	6	7	8	10	11	12	13	15	17	20
	Belt tension ≤ 50% of the capacity	2	2	3	3	4	5	5	6	6	7	8	9	10																													
Belt tension = 100% of the capacity	2	3	5	6	7	8	10	11	12	13	15	17	20																														
Driven shaft		2	2	3	3	3	4	4	5	5	5	6	7	7																													
Sliding guides		2	3	3	3	4	4	5	5	5	6	6	7	8																													

Belt width [mm]		1800	2000	2200	2400	2600	2800	3000																	
Number of sprockes	Drive shaft	<table border="1"> <tr> <td>Belt tension ≤ 50% of the capacity</td> <td>11</td><td>12</td><td>13</td><td>15</td><td>16</td><td>17</td><td>18</td> </tr> <tr> <td>Belt tension = 100% of the capacity</td> <td>22</td><td>25</td><td>27</td><td>30</td><td>32</td><td>35</td><td>37</td> </tr> </table>								Belt tension ≤ 50% of the capacity	11	12	13	15	16	17	18	Belt tension = 100% of the capacity	22	25	27	30	32	35	37
	Belt tension ≤ 50% of the capacity	11	12	13	15	16	17	18																	
Belt tension = 100% of the capacity	22	25	27	30	32	35	37																		
Driven shaft		8	8	9	10	11	12	13																	
Sliding guides		9	9	10	11	12	13	13																	

Mounting

When mounting the sprockets, make sure that you have mounted all sprockets oriented in the same phase.
Only axially lock the central sprocket and leave the other sprockets free to move axially.

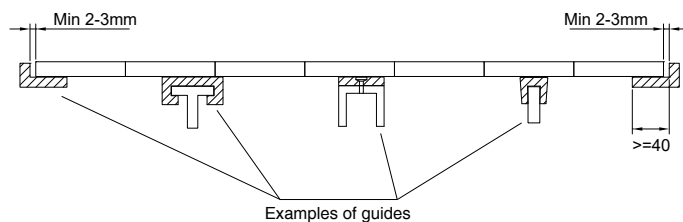

STRAIGHT MODULAR BELTS

Sprockets for EC508 type

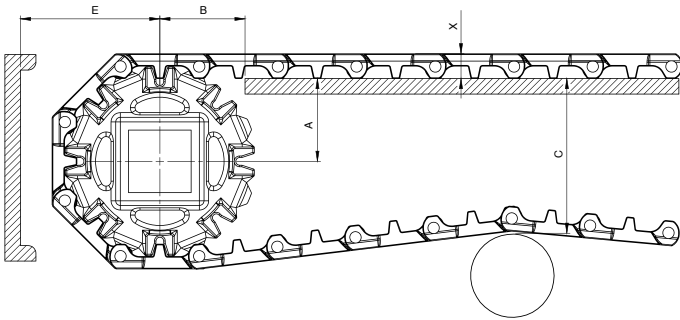

Teeth nr.	A_{max} [mm]	A_{min} [mm]	B1 [mm]	B2 [mm]	C_{max} [mm]
6	42,0	38,0	54	56	89
8	58,0	56,0	62	56	122
10	74,0	72,5	66	56	155
12	90,5	89,0	73	56	187

A_{max} = sliding surface position so that the height of the belt engaging the sprocket oscillates between the sliding surface height and a lower one. The height variation depends on the number of teeth and the pitch of the sprocket.

A_{min} = sliding surface position so that the height of the belt engaging the sprocket oscillates between the sliding surface height and a higher one. The height variation depends on the number of teeth and the pitch of the sprocket.

The choice of A dimensions depends on the items you have to carry. it is always suggested to make a chamfer at the end of the sliding guides.

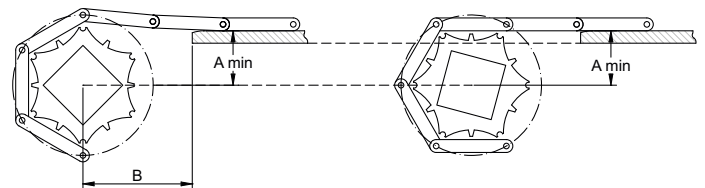
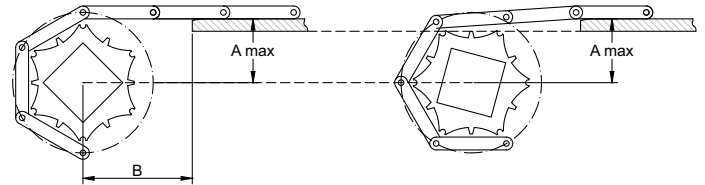

In order to avoid any subsidence of the belt in the area between the guiding strip and the sprockets, it is possible to locate the guides between the sprockets. Two minimum B1 and B2 dimensions are defined.

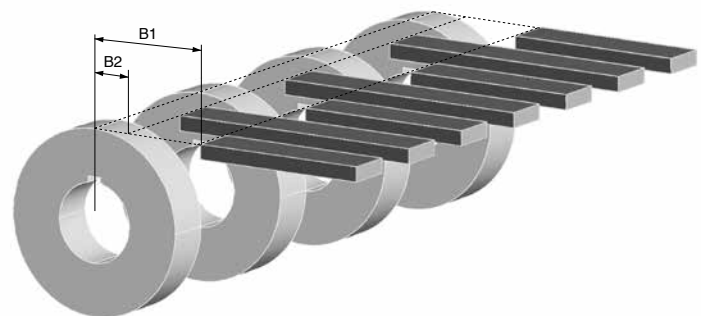

NMMD508C

PITCH 50,8 mm / 2''

STRAIGHT MODULAR BELTS

- Belt type:** closed flat top surface
- Pin diameter:** Ø 7 mm
- Open area:** 0%
- Hole openings:** -
- Minimum width:** 150 mm
- Thickness:** 16 mm
- Accessories:** flights - side wall
- Food Certification:** FDA - EU

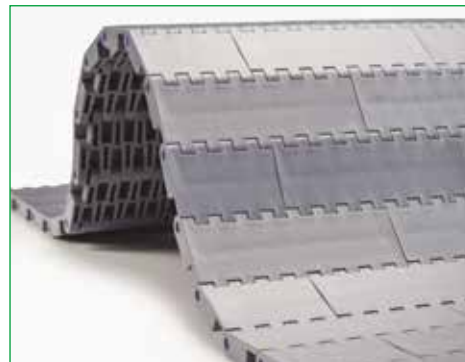

Standard executions

Belt material	Belt color	Pin
PP	White - blue	PP
POM	White - blue - gray	PA

Other materials and colors are available upon request.

Belt material	Pin material	Belt performance [N/m]	Temperature range [°C]	Certification	Weight [kg/m ²]
PP	PP	38000	+5 ÷ +90	FDA - EU	7,8
PE	PE	24000	-73 ÷ +66	FDA - EU	8,6
POM	POM	55000	-43 ÷ +70	FDA - EU	12,2
POM	PA	57000	-40 ÷ +80	FDA - EU	12,2

PP = Polypropylene - PE = Polyethylene - POM = Acetal Resin - PA = Polyamide



Belt width [W]

Minimum [mm]	Standard increment [mm]	Special increment [mm]	Width tolerance* [mm]
150	Multiple: 75	Multiple: 18,75	+/-2 up to 300
			+/-3 up to 600
			+/-4 more than 600

*It is advisable to consider dimensional variations in width based on operating temperatures and humidity when the belt is made of polyamide.

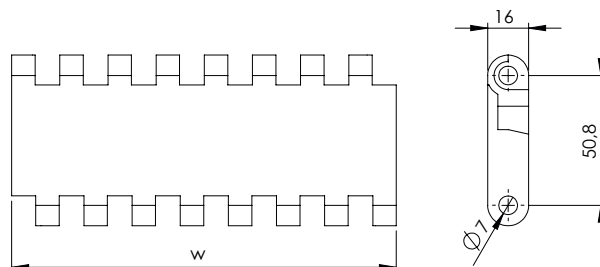

Part number

NMMD 508 C -PP -W

Type _____
 Pitch _____
 Closed flat top surface _____

Belt color: W = white / B = blue _____
 Belt material:
 PO = POM - Acetal Resin / PP = Polypropylene
 PE = Polyethylene / PA = Polyamide _____

PITCH 50,8 mm / 2"

Belt type: open flat surface
Pin diameter: Ø 7 mm
Open area: 25%
Hole openings: 2x8 - 2x12
Minimum width: 150 mm
Thickness: 16 mm
Accessories: flights
Food Certification: FDA - EU



Standard executions

Belt material	Belt color	Pin
PP	White - blue	PP
POM	White - blue	PA

Other materials and colors are available upon request.

Belt material	Pin material	Belt performance [N/m]	Temperature range [°C]	Certification	Weight [kg/m ²]
PP	PP	36000	+5 ÷ +90	FDA - EU	7,3
PE	PE	23000	-73 ÷ +66	FDA - EU	8,1
POM	POM	53000	-43 ÷ +70	FDA - EU	11,5
POM	PA	55000	-40 ÷ +80	FDA - EU	11,5

PP = Polypropylene - PE = Polyethylene - POM = Acetal Resin - PA = Polyamide

Belt width [W]

Minimum [mm]	Standard increment [mm]	Special increment [mm]	Width tolerance* [mm]
150	Multiple: 75	Multiple: 18,75	+/-2 up to 300
			+/-3 up to 600
			+/-4 more than 600

*It is advisable to consider dimensional variations in width based on operating temperatures and humidity when the belt is made of polyamide.

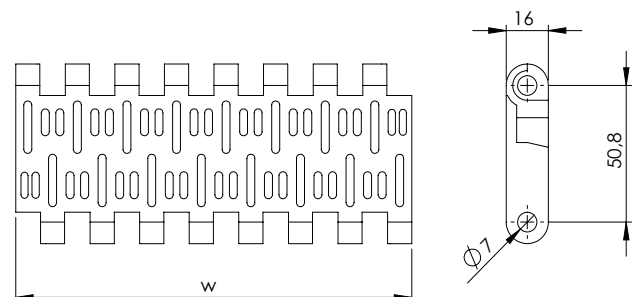

Part number	NMMD 508 P25 -PO -W	
Type	Belt color: W = white / B = blue	
Pitch	Belt material: PO = POM - Acetal Resin / PP = Polypropylene PE = Polyethylene / PA = Polyamide	
Open flat surface at 25%		

NMMD508FG

PITCH 50,8 mm / 2"

STRAIGHT MODULAR BELTS

Belt type: open flat surface flush grid

Pin diameter: Ø 7 mm

Open area: 37%

Hole openings: 20x7 - 9x7 mm

Minimum width: 150 mm

Thickness: 16 mm

Accessories: flights

Food Certification: FDA - EU

Standard executions

Belt material	Belt color	Pin
PP	White - blue	PP
POM	White - blue	PA

Other materials and colors are available upon request.

Belt material	Pin material	Belt performance [N/m]	Temperature range [°C]	Certification	Weight [kg/m ²]
PP	PP	35000	+5 ÷ +90	FDA - EU	7,2
PE	PE	22000	-73 ÷ +66	FDA - EU	7,9
POM	POM	51000	-43 ÷ +70	FDA - EU	11,2
POM	PA	52000	-40 ÷ +80	FDA - EU	11,2

PP = Polypropylene - PE = Polyethylene - POM = Acetal Resin - PA = Polyamide

Belt width [W]

Minimum [mm]	Standard increment [mm]	Special increment [mm]	Width tolerance* [mm]
150	Multiple: 75	Multiple: 18,75	+/-2 up to 300
			+/-3 up to 600
			+/-4 more than 600

*It is advisable to consider dimensional variations in width based on operating temperatures and humidity when the belt is made of polyamide.

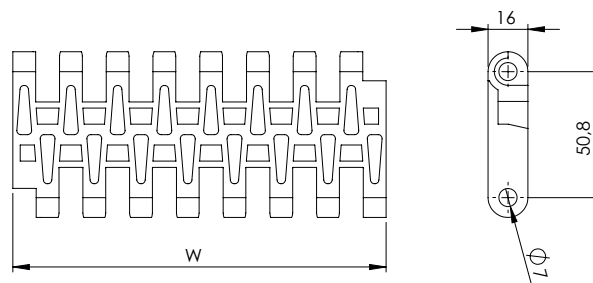

Part number

NMMD 508 FG -PP -W

Type

Pitch

Open flat surface flush grid

Belt color: W = white / B = blue

Belt material:
PO = POM - Acetal Resin / PP = Polypropylene
PE = Polyethylene / PA = Polyamide

Accessories for MD508 type

Flights

Heavy load design



No cling execution

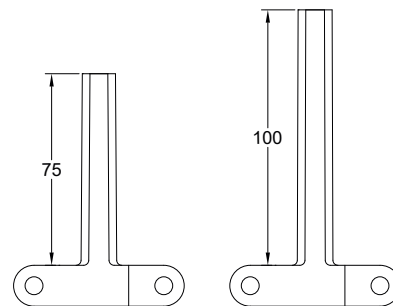
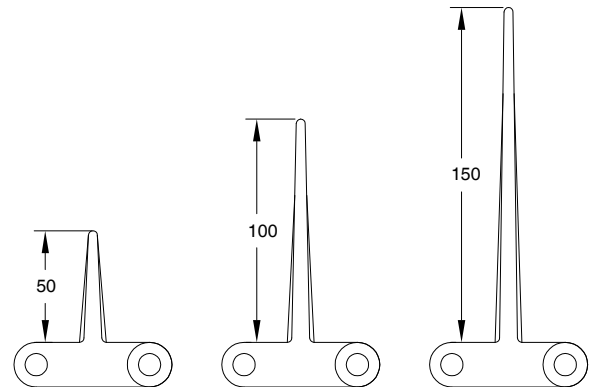

In case of need of flights the following table shows the standard indent. it is possible to have a special indent according to specific customer request.



Standard indent [mm]	Z	37,5	56	75

In the case of wide belts, one or more gaps is recommended between flights to allow the belt to be supported on the return path. The maximum width not supported by guides depends on several factors such as the load on the belt, possible incline of the conveyor, and belt or pin material.

Sprockets for MD508 type



Teeth nr.	Dp [mm]	Do [mm]	A [mm]	B [mm]	Available standard bore	
					Square [mm]	Ø round + set-screw UNI
6	72,33	88	40	7	40x40	25 - 30
8	107,12	123	40	7	40x40	25 - 30
10	141,00	157	40	7	40x40/60x60	30
12	174,33	190	40	7	40x40/60x60	30

Standard material: nylon PA6 fiberglass.
 It is possible to supply sprocket with any number of teeth or any material by CNC machining
 Dp = Pitch diameter
 Do = External tooth diameter

Part number NSMD508C -Q 40 -Z12

Type _____

Bore type: R = round / Q = square _____

Bore dimension (mm) _____

Teeth nr. _____

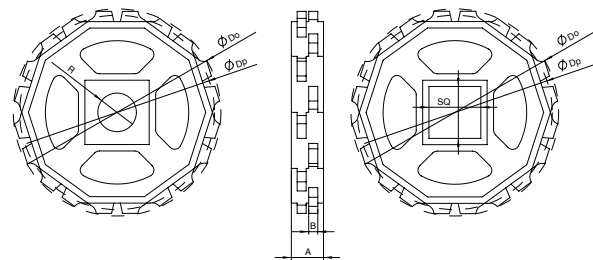

Belt width [mm]		150	300	450	600	750	900	1050	1200	1350	1500	1650	1800	1950	
Number of sprockes	Drive shaft	Belt tension ≤ 50% of the capacity	2	3	4	6	7	9	10	12	13	15	16	18	19
		Belt tension = 100% of the capacity	2	4	6	8	10	12	14	16	18	20	22	24	26
Driven shaft		2	2	2	4	4	6	6	8	8	10	10	12	12	
Sliding guides		2	3	4	4	5	6	6	7	7	8	9	10	11	

Belt width [mm]		2100	2250	2400	2550	2700	
Number of sprockes	Drive shaft	Belt tension ≤ 50% of the capacity	21	22	24	25	27
		Belt tension = 100% of the capacity	28	30	32	34	36
Driven shaft		14	14	16	16	18	
Sliding guides		12	13	14	14	15	

Mounting

When mounting the sprockets, make sure that you have mounted all sprockets oriented in the same phase.
 Only axially lock the central sprocket and leave the other sprockets free to move axially.

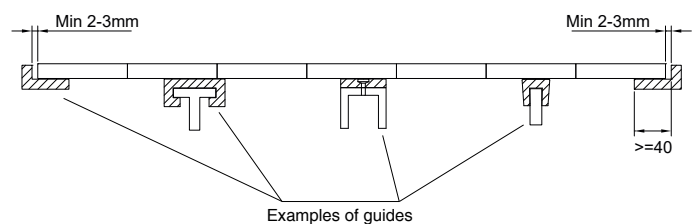

Sprockets for MD508 type

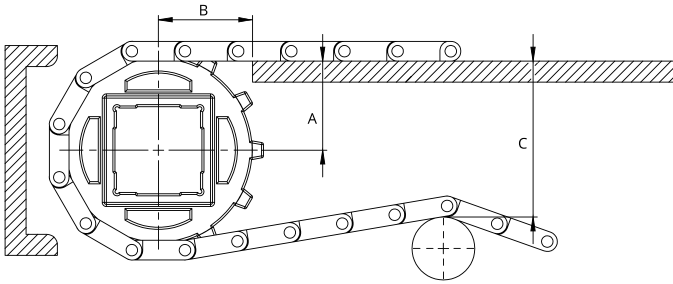

Type	Teeth nr.	A _{max} [mm]	A _{min} [mm]	B1 [mm]	B2 [mm]	C _{max} [mm]
NMMD254C NMMD254FG	6	47	37	54	56	80
	8	61	55	62	56	110
	10	77	72	66	56	150
	12	92	88	73	56	180

A_{max} = sliding surface position so that the height of the belt engaging the sprocket oscillates between the sliding surface height and a lower one. The height variation depends on the number of teeth and the pitch of the sprocket.

A_{min} = sliding surface position so that the height of the belt engaging the sprocket oscillates between the sliding surface height and a higher one. The height variation depends on the number of teeth and the pitch of the sprocket.

The choice of A dimensions depends on the items you have to carry. it is always suggested to make a chamfer at the end of the sliding guides.

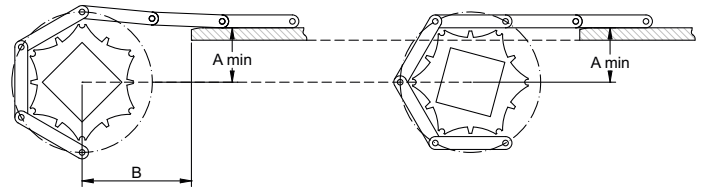
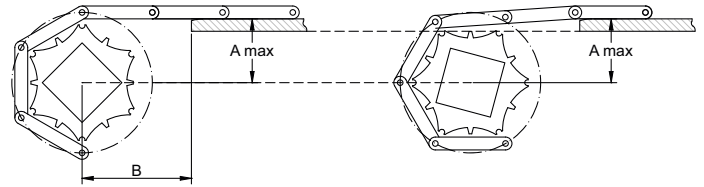

In order to avoid any subsidence of the belt in the area between the guiding strip and the sprockets, it is possible to locate the guides between the sprockets. Two minimum B1 and B2 dimensions are defined.

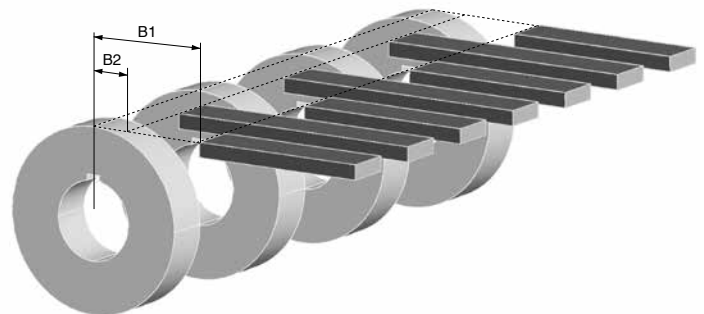

NMHP508C

PITCH 50,8 mm / 2"

STRAIGHT MODULAR BELTS

- Belt type:** closed flat top surface
- Pin diameter:** Ø 7 mm
- Open area:** 0%
- Hole openings:** -
- Minimum width:** 152,4 mm
- Thickness:** 16 mm
- Accessories:** -
- Food Certification:** FDA - EU



Standard executions

Belt material	Belt color	Pin
PP	White - blue	PP
PE	White - blue	POM
POM	White - blue - gray	PA

Other materials and colors are available upon request.



Belt material	Pin material	Belt performance [N/m]	Temperature range [°C]	Certification	Weight [kg/m²]
PP	PP	26970	+5 ÷ +90	FDA - EU	7,8
PE	PE	24080	-73 ÷ +66	FDA - EU	8,6
POM	POM	40600	-43 ÷ +70	FDA - EU	12,2
POM	PA	43400	-40 ÷ +80	FDA - EU	12,0
POM	PP	35300	+5 ÷ +70	FDA - EU	12,0

PP = Polypropylene - PE = Polyethylene - POM = Acetal Resin - PA = Polyamide

Belt width [W]

Minimum [mm]	Standard increment [mm]	Special increment [mm]	Width tolerance* [mm]
152,4	Multiple: 76,2	Multiple: 38,1	+/-2 up to 300
			+/-3 up to 600
			+/-4 more than 600

*It is advisable to consider dimensional variations in width based on operating temperatures and humidity when the belt is made of polyamide.

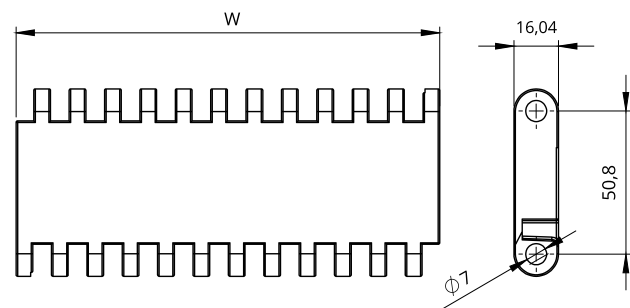

Part number

NMHP 508 P22 -PO -W

Type _____

Pitch _____

Closed flat top surface _____

Belt color: W = white / B = blue / G = gray

Belt material:
 PO = POM - Acetal Resin / PP = Polypropylene
 PE = Polyethylene / PA = Polyamide

PITCH 50,8 mm / 2"

Belt type: open flat surface flush grid

Pin diameter: Ø 7 mm

Open area: 36%

Hole openings: 3,5x18,5 mm

Minimum width: 152,4 mm

Thickness: 16 mm

Accessories: -

Food Certification: FDA - EU



Standard executions

Belt material	Belt color	Pin
PP	Gray	PP
PE	White	POM
POM	Blue	PA

Other materials and colors are available upon request.

Belt material	Pin material	Belt performance [N/m]	Temperature range [°C]	Certification	Weight [kg/m²]
PP	PP	27000	+5 ÷ +90	FDA - EU	6,7
PE	PE	24000	-73 ÷ +66	FDA - EU	7,4
POM	POM	39500	-43 ÷ +70	FDA - EU	10,9
POM	PA	42000	-43 ÷ +70	FDA - EU	10,6
POM	PP	34000	-43 ÷ +70	FDA - EU	10,6

PP = Polypropylene - PE = Polyethylene - POM = Acetal Resin - PA = Polyamide



Belt width [W]

Minimum [mm]	Standard increment [mm]	Special increment [mm]	Width tolerance* [mm]
152,4	Multiple: 76,2	-	+/-2 up to 300 +/-3 up to 600 +/-4 more than 600

*It is advisable to consider dimensional variations in width based on operating temperatures and humidity when the belt is made of polyamide.

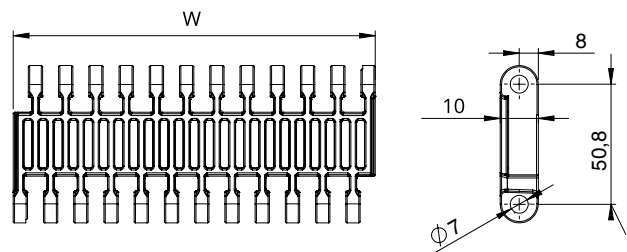

Part number

NMHP 508 FG -PO -W

Type _____
Pitch _____
Open flat surface flush grid

Belt color: W = white / B = blue / G = gray
Belt material:
PO = POM - Acetal Resin / PP = Polypropylene
PE = Polyethylene / PA = Polyamide

NMHP508RR

PITCH 50,8 mm / 2"

STRAIGHT MODULAR BELTS

- Belt type:** open surface rised rib
- Pin diameter:** Ø 7 mm
- Open area:** 36% (max opening 3,5x18,5 mm)
- Surface contact with the product:** 25%
- Minimum width:** 152,4 mm
- Thickness:** 24 mm
- Accessories:** loading and unloading comb
- Food Certification:** FDA - EU



Standard executions

Belt material	Belt color	Pin
PPH	Gray	PPH

Other materials and colors are available upon request.

Belt material	Pin material	Belt performance [N/m]	Temperature range [°C]	Certification	Weight [kg/m ²]
PPH	PPH	26050	+15 ÷ +105	FDA - EU	8,9
POM	POM	39500	-43 ÷ +70	FDA - EU	13,5
POM	PA	42200	-40 ÷ +80	FDA - EU	13,2
POM	PP	34350	+5 ÷ +70	FDA - EU	13,2

PPH = Polypropylene for high temperature - PE = Polyethylene
 POM = Acetal Resin - PA = Polyamide

Belt width [W]

Minimum [mm]	Standard increment [mm]	Special increment [mm]	Width tolerance* [mm]
152,4	Multiple: 76,2	-	+/-2 up to 300
			+/-3 up to 600
			+/-4 more than 600

*It is advisable to consider dimensional variations in width based on operating temperatures and humidity when the belt is made of polyamide.

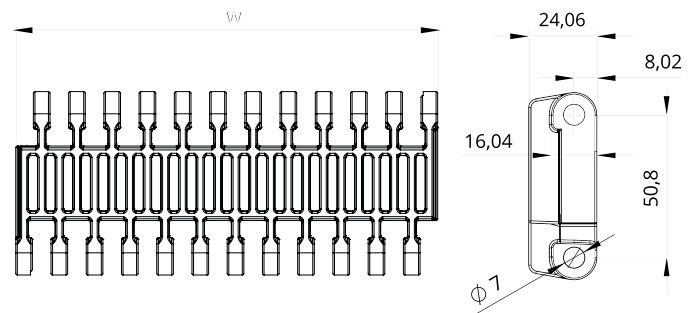

Part number

NMHP 508 RR -PH -G

Type

Pitch

Open surface rised rib

Belt color: G = gray

Belt material:
 PO = POM - Acetal Resin / PP = Polypropylene / PA = Polyamide
 PH = Polypropylene for high temperature

Accessories for NMHP508RR type

Comb for NMHP508RR type

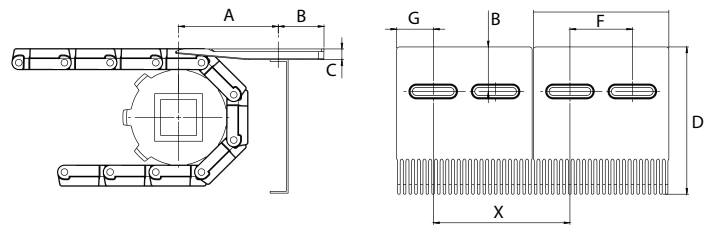

Quote	A	B	C	D	E	F	G	X
[mm]	105-115	25	12,5	146	150	75	37,5	155

Sprockets for HP508 type

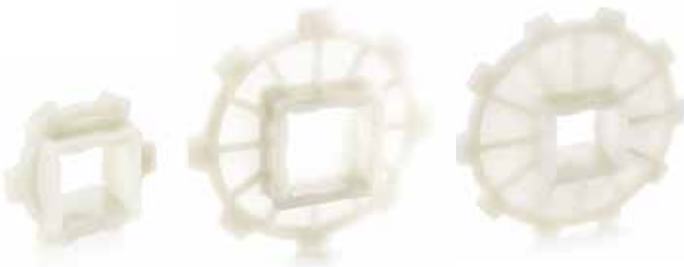

Teeth nr.	Dp [mm]	Do [mm]	A [mm]	B [mm]	Available standard bore	
					Square [mm]	Ø round + set-screw UNI
6	101,6	94,6	40	8,5	40x40	20 - 25 - 30
8	132,7	125,0	40	8,5	40x40	20 - 25 - 30
10	164,4	159,0	40	8,5	40x40	20 - 25 - 30
12	196,3	192,0	40	8,5	40x40	20 - 25 - 30

Standard material: nylon PA6 fiberglass.

It is possible to supply sprocket with any number of teeth or any material by CNC machining

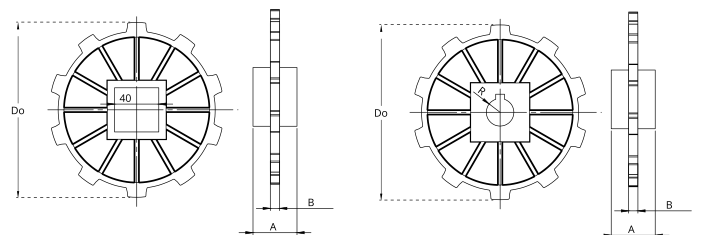

Part number NSHP508 -R 25 -Z6

Type _____

Bore type: R = round / Q = square _____

Bore dimension (mm) _____

Teeth nr. _____

Belt width [mm]		152,4	228,6	304,8	381	457,2	533,4	609,6	685,8	762	838,2	914,4	990,6	1066,8	1143	1219,2	1295,4	1371,6	1447,8
Number of sprockets	Drive shaft	2	2	2	3	3	4	4	5	5	5	6	6	7	7	8	8	9	9
	Belt tension ≤ 50% of the capacity	1	2	3	4	5	6	7	8	9	10	11	12	13	14	15	16	17	18
	Belt tension = 100% of the capacity	1	2	3	4	5	6	7	8	9	10	11	12	13	14	15	16	17	18
	Driven shaft	2	2	2	3	3	3	3	3	4	4	4	4	5	5	6	6	6	7
	Sliding guides	2	2	3	3	3	4	4	4	5	5	5	5	6	6	6	7	7	7

Belt width [mm]		1524	1600,2	1676,4	1752,6	1828,8	1905	1981,2	2057,4	2133,6	2209,8	2286	2514,6	2743,2	2971,8	3200,4	3429	3657,6	3810
Number of sprockets	Drive shaft	9	10	10	11	11	12	12	13	13	13	14	15	17	18	19	21	22	23
	Belt tension ≤ 50% of the capacity	19	20	20	21	22	23	24	25	26	27	28	31	34	37	40	42	45	47
	Belt tension = 100% of the capacity	19	20	20	21	22	23	24	25	26	27	28	31	34	37	40	42	45	47
	Driven shaft	7	7	8	8	9	9	9	10	10	10	11	11	12	13	14	15	16	17
	Sliding guides	8	8	8	9	9	9	9	10	10	10	11	12	12	13	14	15	16	17

Sprockets for HP508 type

Mounting

When mounting the sprockets, make sure that you have mounted all sprockets oriented in the same phase.
Only axially lock the central sprocket and leave the other sprockets free to move axially.

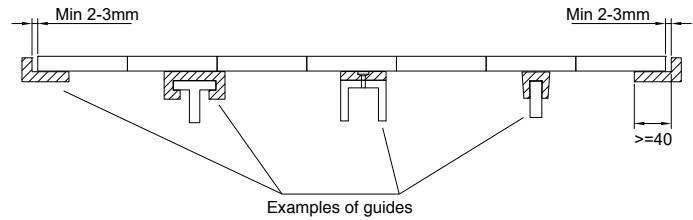

STRAIGHT MODULAR BELTS

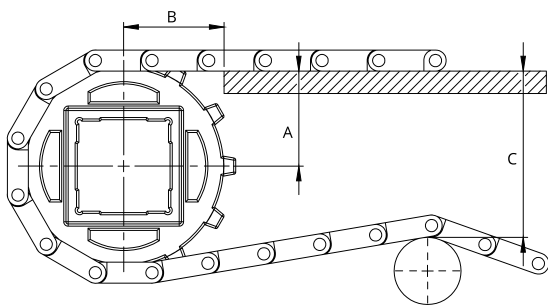

Teeth nr.	A _{max} [mm]	A _{min} [mm]	B1 [mm]	B2 [mm]	C _{max} [mm]
6	42,0	38,0	54	56	89
8	58,0	56,0	62	56	122
10	74,0	72,5	66	56	155
12	90,5	89,0	73	56	187

A_{max} = sliding surface position so that the height of the belt engaging the sprocket oscillates between the sliding surface height and a lower one. The height variation depends on the number of teeth and the pitch of the sprocket.

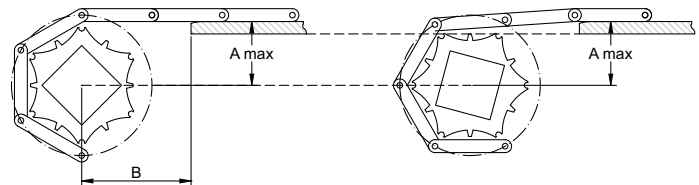

A_{min} = sliding surface position so that the height of the belt engaging the sprocket oscillates between the sliding surface height and a higher one. The height variation depends on the number of teeth and the pitch of the sprocket.

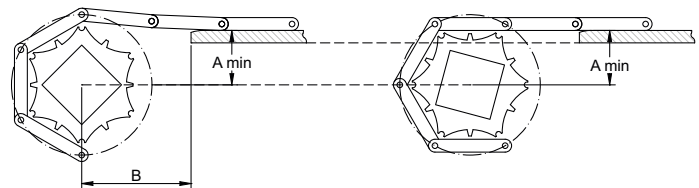

The choice of A dimensions depends on the items you have to carry.
it is always suggested to make a chamfer at the end of the sliding guides.

In order to avoid any subsidence of the belt in the area between the guiding strip and the sprockets, it is possible to locate the guides between the sprockets. Two minimum B1 and B2 dimensions are defined.

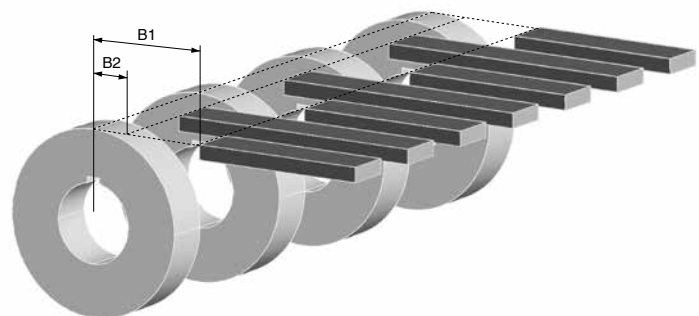

CURVED MODULAR BELTS

A large, detailed photograph of a blue curved modular belt. The belt is composed of many interlocking plastic modules, each with a specific shape that allows them to fit together to form a continuous, curved surface. The lighting highlights the texture and three-dimensional nature of the modules.

Curved modular belts

PITCH 25,4 mm / 1"

Belt type: open flat surface
Pin diameter: Ø 5 mm
Open area: 38%
Hole openings: 7,5x12
Minimum width: 83 mm
Thickness: 10,8 mm
Accessories: flights
Food Certification: FDA - EU
Collapse factor: 2,1 - 2,4



Standard executions

Belt material	Belt color	Pin
PP	Blue - white	POM
POM	Blue - white	POM

Other materials and colors are available upon request.



Belt material	Pin material	Belt performance [N/m]		Temperature range [°C]	Certification	Weight [kg/m²]
		Straight strand	Curved strand			
PP	PP	9000	1200	+5 ÷ +90	FDA - EU	5,1
POM	POM	16250	1600	-43 ÷ +70	FDA - EU	6,9
POM	PA	17600	1700	-40 ÷ +80	FDA - EU	6,6
POM	PP	14300	1400	+5 ÷ +70	FDA - EU	6,6

PP = Polypropylene - PE = Polyethylene - POM = Acetal Resin - PA = Polyamide

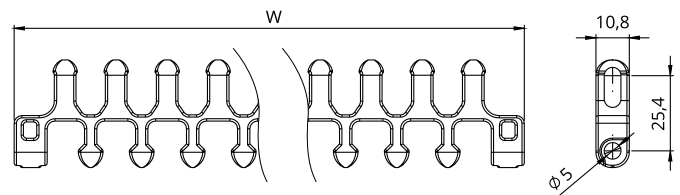

Part number	NREC 254 R -PO -W	
Type		Belt color: W = white / B = blue Belt material: PO = POM - Acetal Resin / PP = Polypropylene PA = Polyamide
Pitch		
Open flat surface		

Hold Down and TAB for NREC254R

Layout of guides in different belt types:

STANDARD TYPE

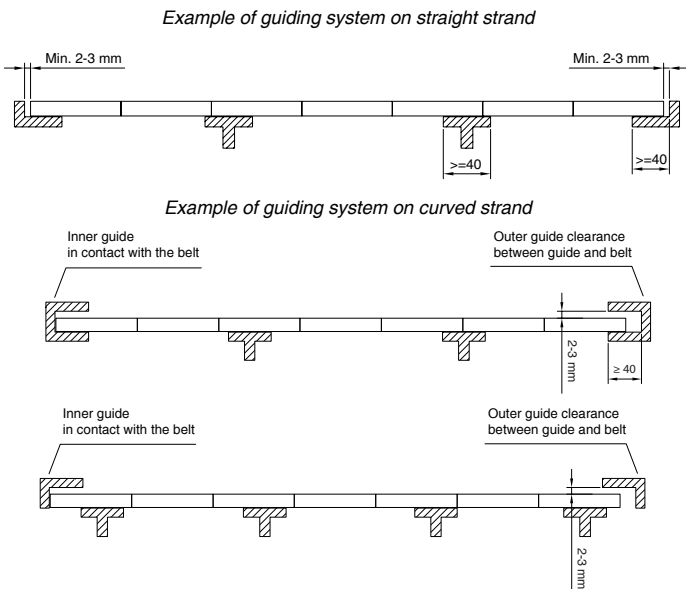

TAB RETENTION SYSTEM

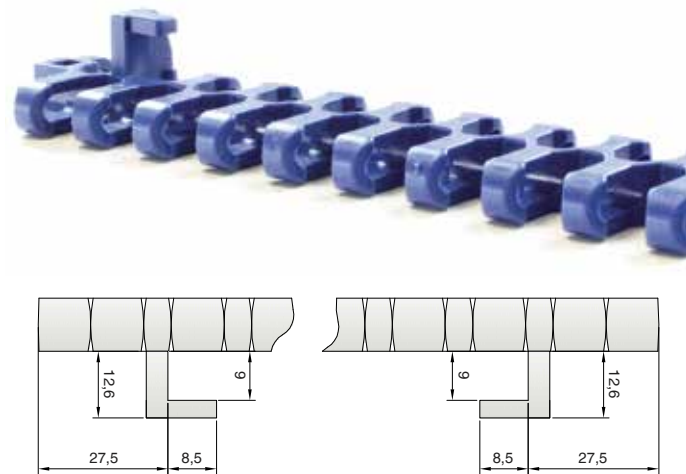

The TAB system is available on one or both sides of the belt depending on whether the belt curves in one or both directions. The system is designed primarily to avoid belt lifting in the curves and minimize belt width with respect to the size of the objects carried that may be wider than the belt itself. You can use the hook as contact surface and let them slide on the guides. It is important to evaluate the strength capacity of the TAB system combined with belt tension, speed, and belt radius.

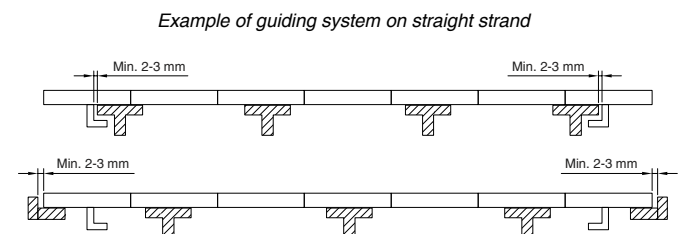

Configuration suitable for significant forces on the belt and sustained speeds:

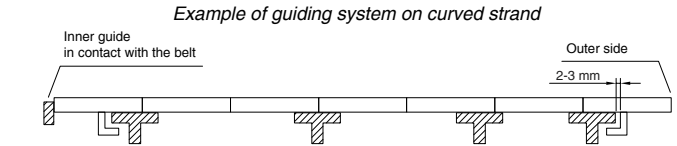

Configuration suitable for limited forces on the belt and speed up to 20m / min. In this configuration you can also make larger curves without collapsing the belt.

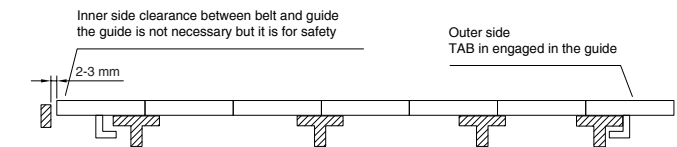

LATERAL TAB RETENTION SYSTEM

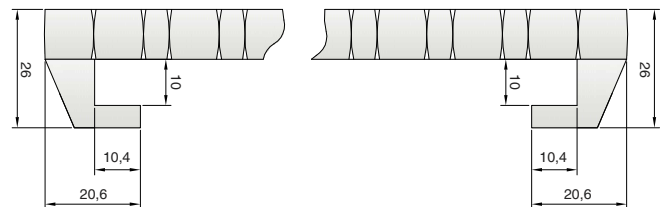

The Lateral TAB system is applicable on one or both sides of the belt depending on whether the belt curves in one or both directions.

The system is designed primarily to avoid belt lifting in the curves and at the same time allow the transported objects to be larger than the belt itself. The hook is designed to be used in contact with the sliding guides.

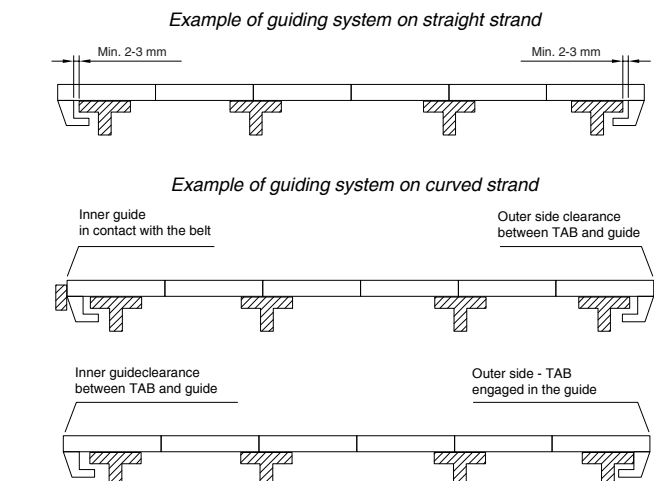

CURVED MODULAR BELTS

PITCH 25,4 mm / 1"

- Belt type:** rubber top open surface
- Pin diameter:** Ø 5 mm
- Open area:** 38%
- Hole openings:** 7,5x12
- Minimum width:** 83 mm
- Thickness:** 10,8 mm+5 mm
- Accessories:** flights
- Food Certification:** FDA - EU
- Collapse factor:** 2,1 - 2,4

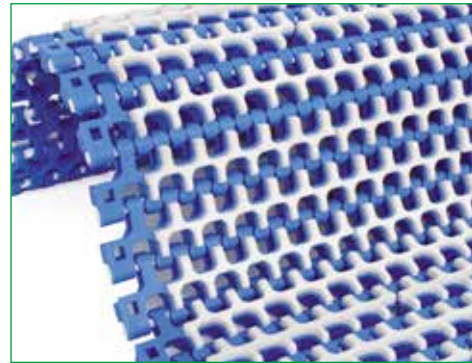

Standard executions

Belt material	Belt color	Pin
PP	Blue - white	POM

Other materials and colors are available upon request.

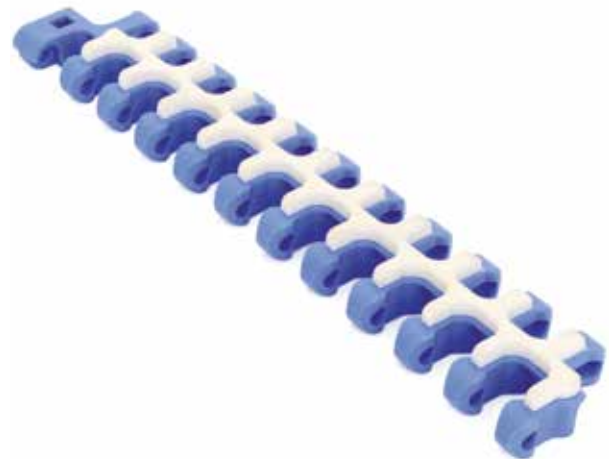

Belt material	Pin material	Belt performance [N/m]		Range di temperature [°C]	Certification	Weight [kg/m²]
		Straight strand	Curved strand			
PP	PP	9000	1200	+5 ÷ +90	FDA - EU	5,1
POM	POM	16250	1600	-43 ÷ +70	FDA - EU	6,9
POM	PA	17600	1700	-40 ÷ +80	FDA - EU	6,6
POM	PP	14300	1400	+5 ÷ +70	FDA - EU	6,6

PP = Polypropylene - PE = Polyethylene - POM = Acetal Resin - PA = Polyamide

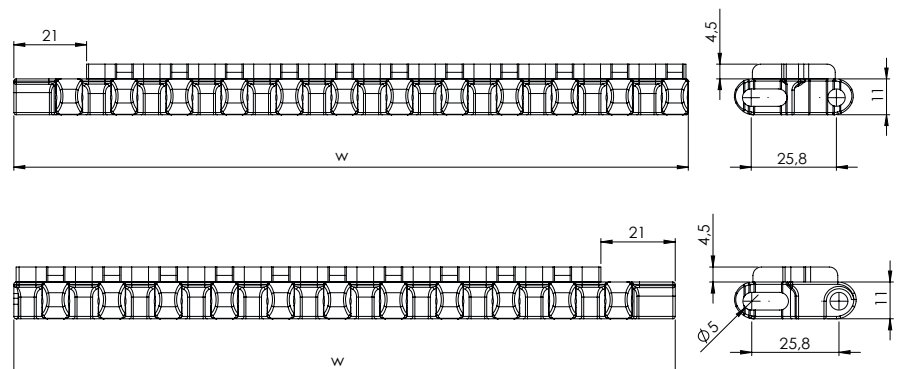

Part number

NREC 254 RT -PO -W

Type _____
 Pitch _____
 Rubber top open surface _____

Belt color: W = white / B = blue

Belt material:
 PO = POM - Acetal Resin / PP = Polypropylene
 PA = Polyamide

Sprockets for NREC254



Teeth nr.	Dp [mm]	Do [mm]	A [mm] Solid	C [mm] Split	B [mm]	Available standard bore	
						Square [mm]	Ø round + set-screw UNI
8	68,4	67,7	30	40	7	25x25	25
10	82,8	85,7	30	40	7	40x40	25 - 30
12	98,9	102,0	30	40	7	40x40	25 - 30
15	123,1	126,0	30	40	7	40x40	25 - 30
16	134,1	131,0	30	40	7	40x40	25 - 30
18	147,4	152,3	30	40	7	40x40	25 - 30

Standard material: nylon PA6 fiberglass.
 It is possible to supply sprocket with any number of teeth or any material by CNC machining
 Dp = Pitch diameter
 Do = External tooth diameter

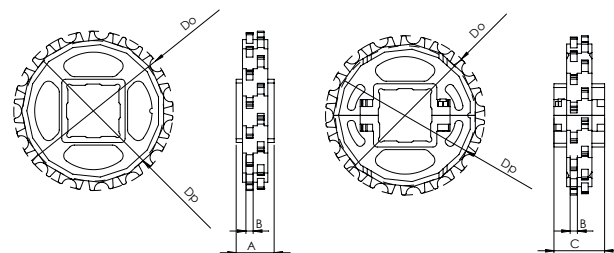

Part number NSEC254TR -Q 40 -Z12

Type _____

Bore type: R = round / Q = square _____

Bore dimension (mm) _____

Teeth nr. _____

Belt width W [mm]		167	200	250	300	350	400	450	500	550	600	700	800	900	1000		
Number of sprockes	Drive shaft	Belt tension ≤ 50% of the capacity		2	2	2	3	3	4	4	4	5	6	6	7	8	8
		Belt tension = 100% of the capacity		2	2	3	4	5	5	5	5	7	8	9	11	13	14
	Driven shaft	2	2	2	2	3	3	3	4	4	4	4	5	5	5	5	
	Sliding guides	2	2	2	3	3	4	4	4	4	5	6	7	7	8	8	

Belt width increment: 16,7 mm

Example of guiding system on straight strand

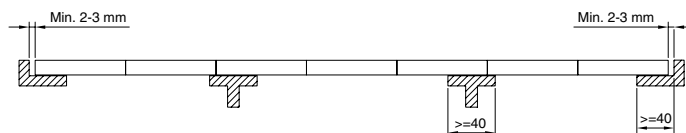

Example of guiding system on curved strand

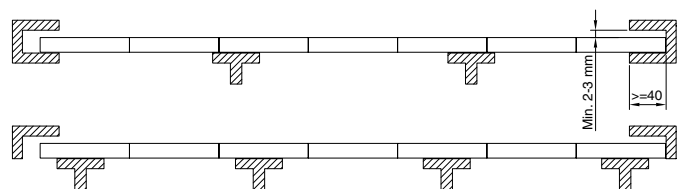

Mounting

When mounting the sprockets, make sure that you have mounted all sprockets oriented in the same phase.
 Only axially lock the central sprocket and leave the other sprockets free to move axially.

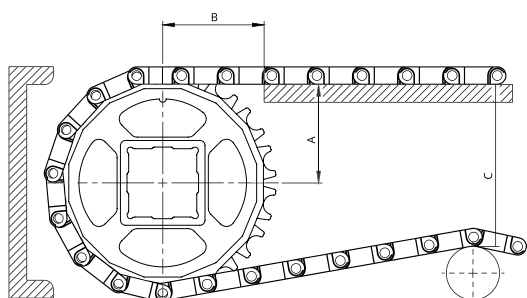

Teeth nr.	A _{max} [mm]	A _{min} [mm]	B1 [mm]	B2 [mm]	C _{max} [mm]
8	28,7	26,1	38	28	54
10	37,7	36,3	40	28	75
12	45,2	43,6	44	28	91
15	56,5	54,5	50	28	116
16	60,6	59,6	52	28	120
18	67,8	65,4	57	28	140

CURVED MODULAR BELTS

Sprockets for NREC254R type

A_{max} = sliding surface position so that the height of the belt engaging the sprocket oscillates between the sliding surface height and a lower one. The height variation depends on the number of teeth and the pitch of the sprocket.

A_{min} = sliding surface position so that the height of the belt engaging the sprocket oscillates between the sliding surface height and a higher one. The height variation depends on the number of teeth and the pitch of the sprocket.

The choice of A dimensions depends on the items you have to carry. it is always suggested to make a chamfer at the end of the sliding guides.

In order to avoid any subsidence of the belt in the area between the guiding strip and the sprockets, it is possible to locate the guides between the sprockets. Two minimum B1 and B2 dimensions are defined.

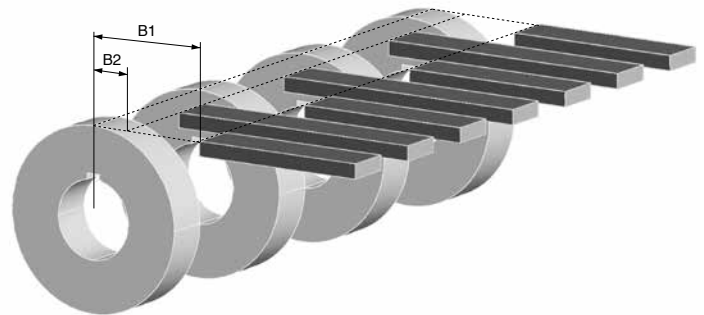
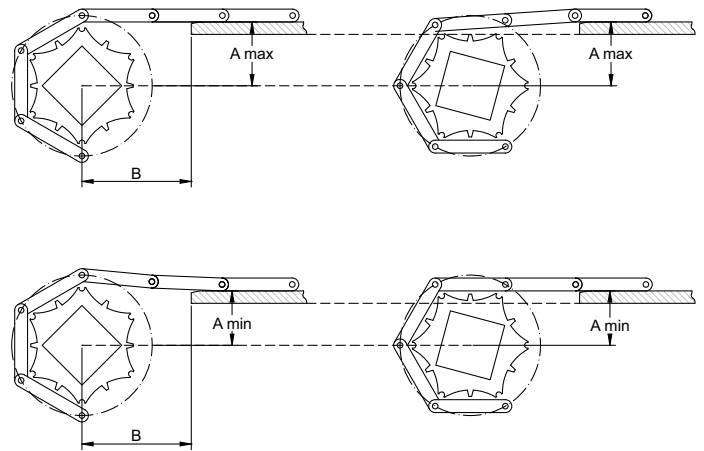

- A = belt width
- B = straight strand before the drive shaft. Min. 2 x belt width
- C = straight strand before return shaft. Min. 1,5 x belt width
- D = straight strand between two curves. Min. 2 x belt width
- E = curved belt length = $(R + A) \times \text{angle in radians}$
- R = internal radius. R minimum = belt width x collapsing factor.
Collapsing factor variable from 2,1 to 2,4 depending on belt width.

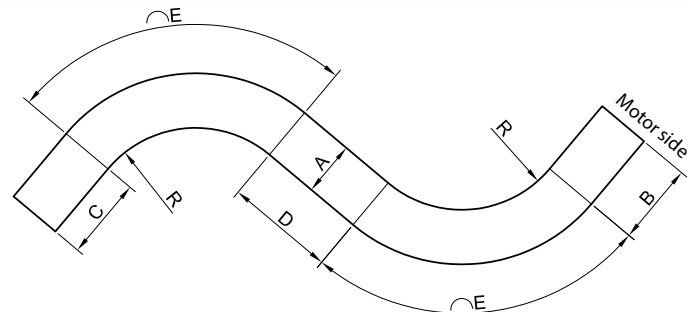

Example:

A = 200 mm
 R = $200 \cdot 2,1 = 420$ mm
 E = $(420 + 200) \cdot \frac{\pi}{2} = 973$ mm

Guides available for belt type NMEC254R

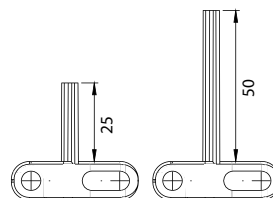

Caution: Consider that in the curves the guides get closer to each other. If possible, always specify the distance of the guides from the belt edge.

Belt width [mm]	200	250	300	350	400	450	500	550	600	650	700	750	800	850	900
Collapsing factor f_c	2,1	2,15	2,19	2,23	2,26	2,28	2,30	2,32	2,34	2,35	2,36	2,37	2,38	2,39	2,40
Minimum internal radius [mm]	420	538	657	781	904	1026	1150	1276	1404	1528	1652	1778	1904	2032	2160

NREC254TR

PITCH 25,4 mm / 1"

- Belt type:** open flat surface
- Pin diameter:** Ø 5 mm
- Open area:** 38%
- Hole openings:** 6,5x12 mm
- Minimum width:** 167 mm
- Thickness:** 13 mm
- Accessories:** tab ext
- Food Certification:** FDA - EU
- Collapse factor:** 1,4 - 1,6

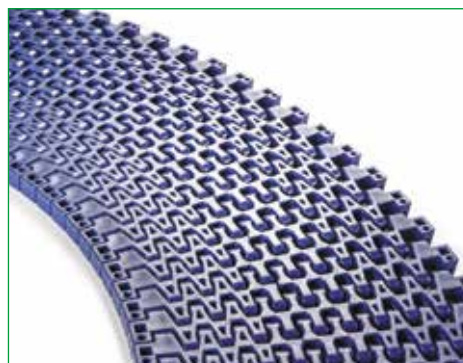

Standard executions

Belt material	Belt color	Pin
PP	Blue - white	POM
POM	Blue - white	POM

Other materials and colors are available upon request.



Belt material	Pin material	Belt performance [N/m]		Range di temperature [°C]	Certification	Weight [kg/m²]
		Straight strand	Curved strand			
PP	PP	9400	1250	+5 ÷ +90	FDA - EU	5,6
POM	POM	17050	1680	-43 ÷ +70	FDA - EU	7,2
POM	PA	18400	1800	-40 ÷ +80	FDA - EU	7,1
POM	PP	15000	1500	+5 ÷ +70	FDA - EU	7,1

PP = Polypropylene - PE = Polyethylene - POM = Acetal Resin - PA = Polyamide

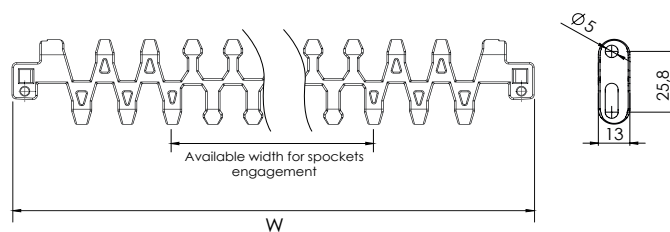

Part number

NREC 254 TR -PO -W

Type _____

Pitch _____

Open flat surface _____

Belt color: W = white / B = blue

Belt material:
PO = POM - Acetal Resin / PP = Polypropylene
PA = Polyamide

CURVED MODULAR BELTS

TAB EXT for NREC254TR type

Layout of guides in different belt types:

STANDARD TYPE

Example of guiding system on straight strand

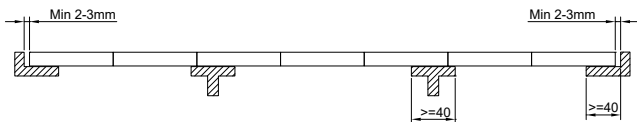

Example of guiding system on curved strand

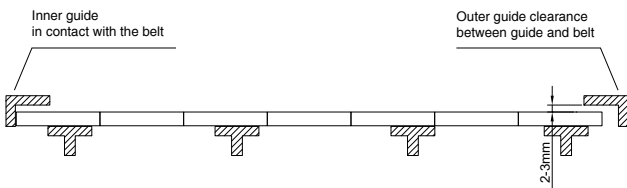
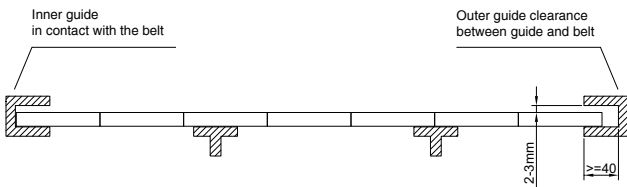

TAB EXT execution can be applied to one or both edge of the belt according to specific need.

This system is primarily used to minimize the belt width compared to the object to be conveyed, infact the object can protrude from the belt side since there is no need of lateral guide higher or hooking the belt side.

By reducing the width of the belt it is also possible to reduce its the inner radius. This is common in example for carton boxes.

The TAB EXT system can be applied also in case it is needed to let the conveyed goods leave the belt laterally.

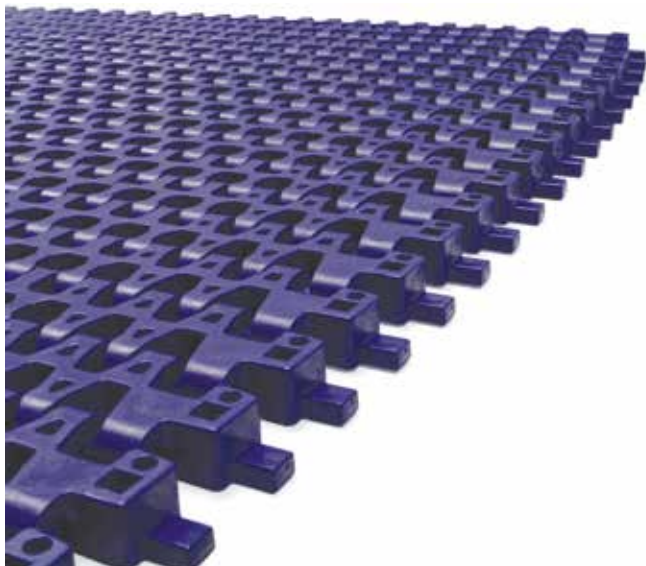

TAB EXT RETENTION SYSTEM



Example of guiding system on straight strand

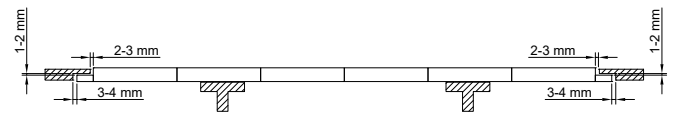

Example of guiding system on curved strand

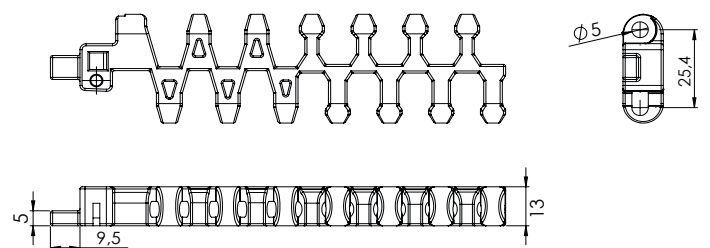
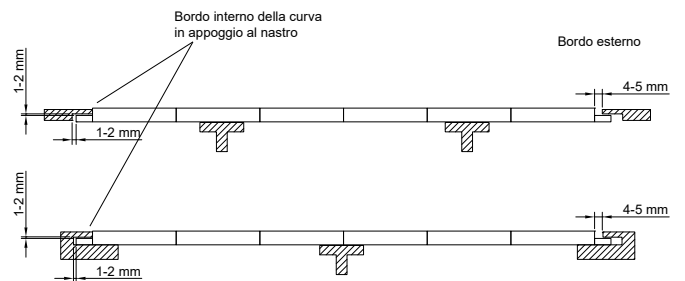

Sprockets for NREC254TR type



Teeth nr.	Dp [mm]	Do [mm]	A [mm] Solid	C [mm] Split	B [mm]	Available standard bore	
						Square [mm]	Ø round + set-screw UNI
8	68,4	67,7	30	40	7	25x25	25
10	82,8	85,7	30	40	7	40x40	25 - 30
12	98,9	102,0	30	40	7	40x40	25 - 30
15	123,1	126,0	30	40	7	40x40	25 - 30
16	134,1	131,0	30	40	7	40x40	25 - 30
18	147,4	152,3	30	40	7	40x40	25 - 30

Standard material: nylon PA6 fiberglass.
 It is possible to supply sprocket with any number of teeth or any material by CNC machining
 Dp = Pitch diameter
 Do = External tooth diameter

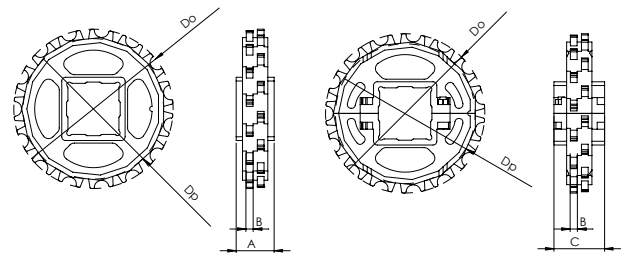

Part number NSEC254TR -Q 40 -Z12

Type _____

Bore type: R = round / Q = square _____

Bore dimension (mm) _____

Teeth nr. _____

Belt width W [mm]		167	200	250	300	350	400	450	500	550	600	700	800	900	1000		
Number of sprockes	Drive shaft	Belt tension ≤ 50% of the capacity		2	2	2	3	3	4	4	4	5	6	6	7	8	8
		Belt tension = 100% of the capacity		2	2	3	4	5	5	5	5	7	8	9	11	13	14
	Driven shaft	2	2	2	2	3	3	3	4	4	4	4	5	5	5	5	
	Sliding guides	2	2	2	3	3	4	4	4	4	5	6	7	7	8	8	

Belt width increment: 16,7 mm

Mounting

When mounting the sprockets, make sure that you have mounted all sprockets oriented in the same phase.
 Only axially lock the central sprocket and leave the other sprockets free to move axially.

Example of guiding system on straight strand

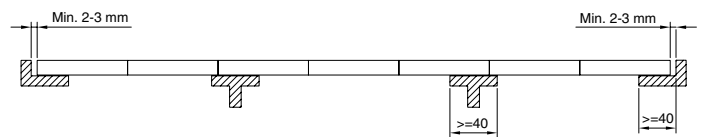

Example of guiding system on curved strand

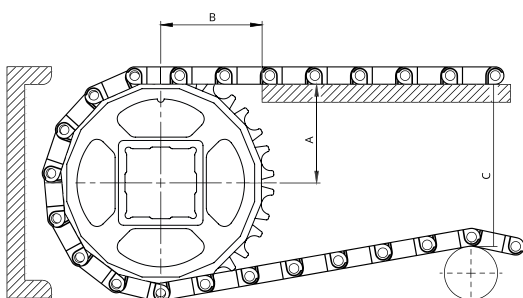
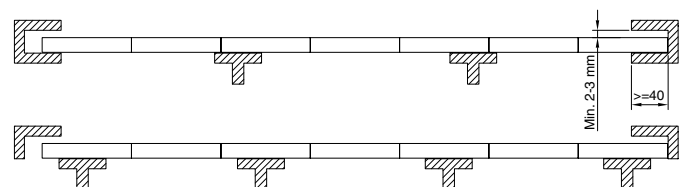

Teeth nr.	A _{max} [mm]	A _{min} [mm]	B1 [mm]	B2 [mm]	C _{max} [mm]
8	28,7	26,1	38	28	54
10	37,7	36,3	40	28	75
12	45,2	43,6	44	28	91
15	56,5	54,5	50	28	116
16	60,6	59,6	52	28	120
18	67,8	65,4	57	28	140

CURVED MODULAR BELTS

Sprockets for NREC254TR type

A_{max} = sliding surface position so that the height of the belt engaging the sprocket oscillates between the sliding surface height and a lower one. The height variation depends on the number of teeth and the pitch of the sprocket.

A_{min} = sliding surface position so that the height of the belt engaging the sprocket oscillates between the sliding surface height and a higher one. The height variation depends on the number of teeth and the pitch of the sprocket.

The choice of A dimensions depends on the items you have to carry. it is always suggested to make a chamfer at the end of the sliding guides.

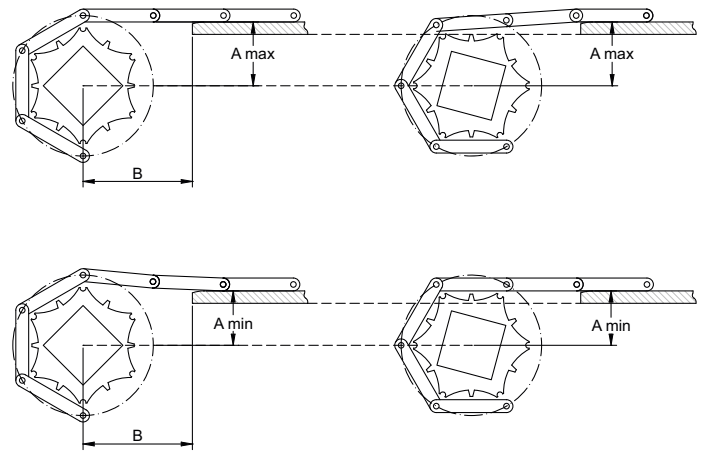

In order to avoid any subsidence of the belt in the area between the guiding strip and the sprockets, it is possible to locate the guides between the sprockets. Two minimum B1 and B2 dimensions are defined.

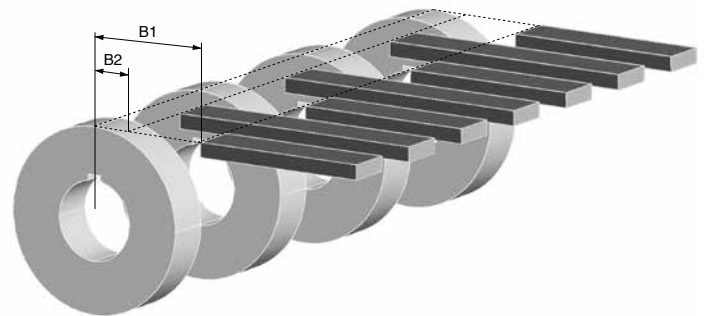

- A = belt width
- B = straight strand before the drive shaft.
Min. 2 x belt width
- C = straight strand before return shaft. Min. 1,5 x belt width
- D = straight strand between two curves. Min. 1 x belt width
- E = curved belt length = $(R + A) \times \text{angle in radians}$
- R = internal radius. R minimum = belt width x collapsing factor.
collapsing factor variable from 1,4 to 1,6 depending on belt width.

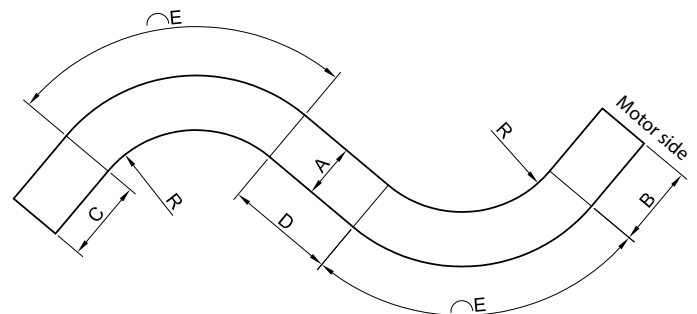

Example:

A = 200 mm
 $R = 200 \cdot 1,4 = 280 \text{ mm}$
 $E = (280 + 200) \cdot \frac{\pi}{2} = 753 \text{ mm}$

Belt width [mm]	200	250	300	350	400	450	500	550	600	650	700	750	800	850	900
Collapsing factor f_c	1,40	1,44	1,47	1,50	1,52	1,54	1,55	1,56	1,57	1,58	1,59	1,60	1,61	1,62	1,63
Minimum internal radius [mm]	280	360	441	525	608	693	775	858	942	1027	1113	1200	1288	1377	1467

NREC508S

PITCH 50,8 mm / 2"

- Execution:** open flat surface
- Pin diameter:** Ø 6 mm - inox AISI 304
- Open area:** 66% straight - 47% collapsed area hole
- Size:** 14x18 mm
- Minimum width:** 406 mm - 16"
- Thickness:** 14,5 mm
- Accessories:** sidewall - space liner
- Food certification:** FDA - EU
- Collapse factor:** 1,6 - 1,9 - 2,2

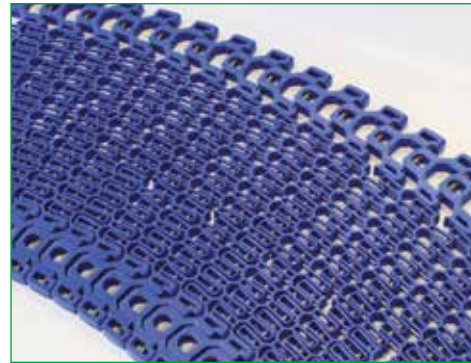

Standard executions

Belt material	Belt color	Pin
PPH	White	Inox AISI 304
PPF	White	Inox AISI 304
POM	Blue	Inox AISI 304

Other materials and colors are available upon request.



Belt material	Pin material	Belt strength [N/m]		Temperature range [°C]
		Straight	Cornering	
PPH	Inox AISI 304	4200	1900	+20 ÷ +70 humid condition
PPF	Inox AISI 304	6400	2900	+20 ÷ +105 humid condition
POM	Inox AISI 304	6000	2700	-40 ÷ +70

PPH = Polypropylene for high temperature - PPF = Polypropylene FG loaded
 POM = Acetal

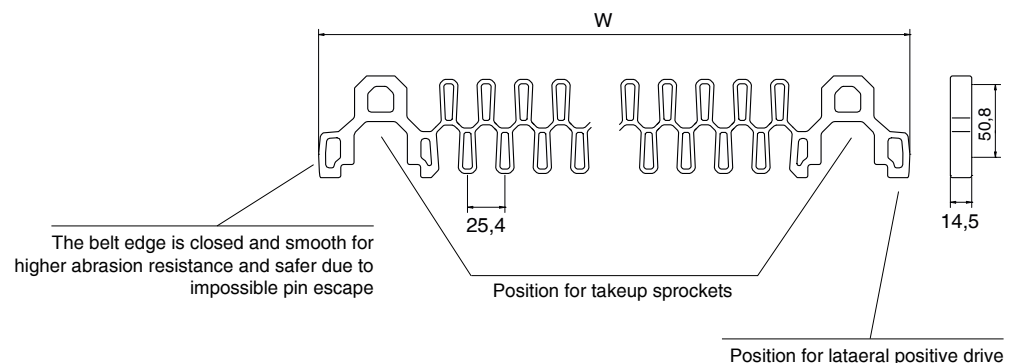

Part number

NREC 508 S -PO -B

Type _____

Pitch _____

Belt surface open flat surface _____

Belt color : W = white / B = blue

Belt material: PO = POM - acetal
 PPH = Polypropylene for high temperature
 PPF = Polypropylene FG loaded

CURVED MODULAR BELTS

Accessories and sprocket for series NREC508S

Part number	NSEC254TR	-Q	40	-Z12
Type				
Bore type: R = round / Q = square				
Bore size (mm)				
Teeth number				

Belt width W [mm]		406	457	508	558	609	660	711	762	812	863	914	965	1016
Belt width W [inch]		16"	18"	20"	22"	24"	26"	28"	30"	32"	34"	36"	38"	40"
Sprockets nr.	Take up shaft	2	2	2	2	2	2	2	2	2	2	2	2	2
	Tensioner shaft	2	2	2	2	2	2	2	2	2	2	2	2	2
	Lateral sprocket on spiral turns	1 each turn												

Not standard width increments: 25.4mm / 1"

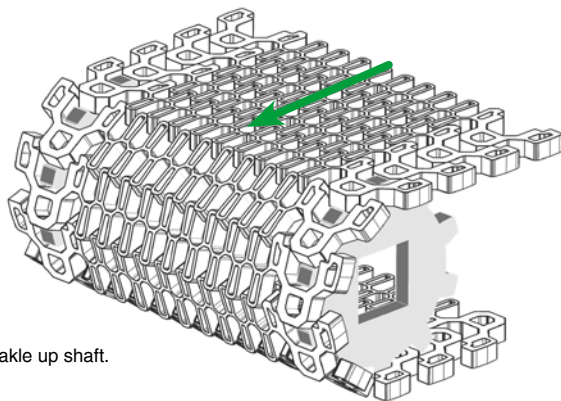

Take up shaft.

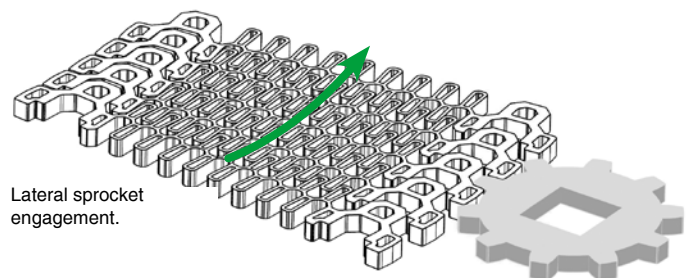

Lateral sprocket engagement.

Standard width and collaps factor

Belt width	[mm]	406	457	508	558	609	660	711	762	812	863	914	965	1016	
	[inch]	16	18	20	22	24	26	28	30	32	34	36	38	40	
Inner radius	RC 1,6	[mm]	650	732	813	893	975	96	1138	1220	1300	1381	1463	1544	1626
		[inch]	25,6	28,8	32	35,2	38,4	3,8	44,8	48	51,2	54,4	57,6	60,8	64
	RC 1,9	[mm]	772	869	966	1061	1158	114	1351	1448	1543	1640	1737	1834	1931
		[inch]	30,4	34,2	38	41,8	45,6	4,5	53,2	57	60,7	64,6	68,4	72,2	76
	RC 2,2	[mm]	894	1006	1118	1228	1340	132	1565	1677	1787	1899	2011	2123	2236
		[inch]	35,2	39,6	44	48,3	52,8	5,2	61,6	66	70,4	74,8	79,2	83,6	88
Carry way	Conveyng side	2	2	2	2	2	2	2-3	2-3	2-3	2-3	3	3	3	
	Return side	2	2	2	2	2	2	2	2	2	2	2	2	2	

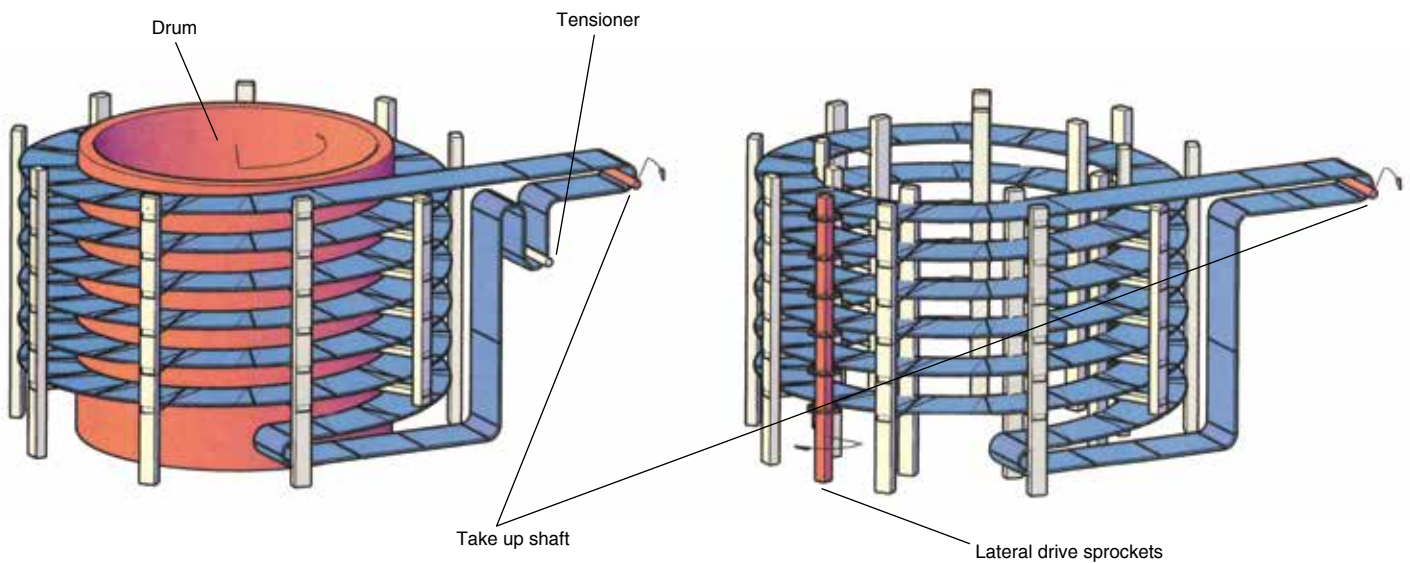

Thanks to the strength and rigidity of the stainless steel pins, the number of guides / supports can be drastically reduced compared to other belts with plastic pins. The distance between the guides is determined on the basis of the weight of the product and its distribution on the belt. In most cases, this distance is between 450 and 800 mm. On the way back, the guides can be spaced 1 meter apart. Thanks to the tight tolerance of the belt width, the lateral space between the belt and the guides can be a few millimeters, however it is important to take into account the thermal expansion of the belt which corresponds to the expansion of the stainless steel pin.

Drum drive

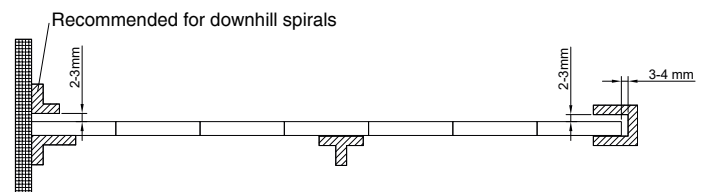

Lateral drive

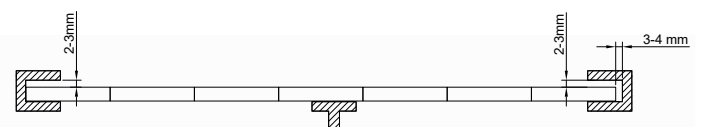

Sidewall and line spacer

The belt is available with 25 or 50 mm sidewall integrally molded. Also available are removable line spacer 25 mm high. The line spacer can be positioned every 1/2" along the width of the belt.

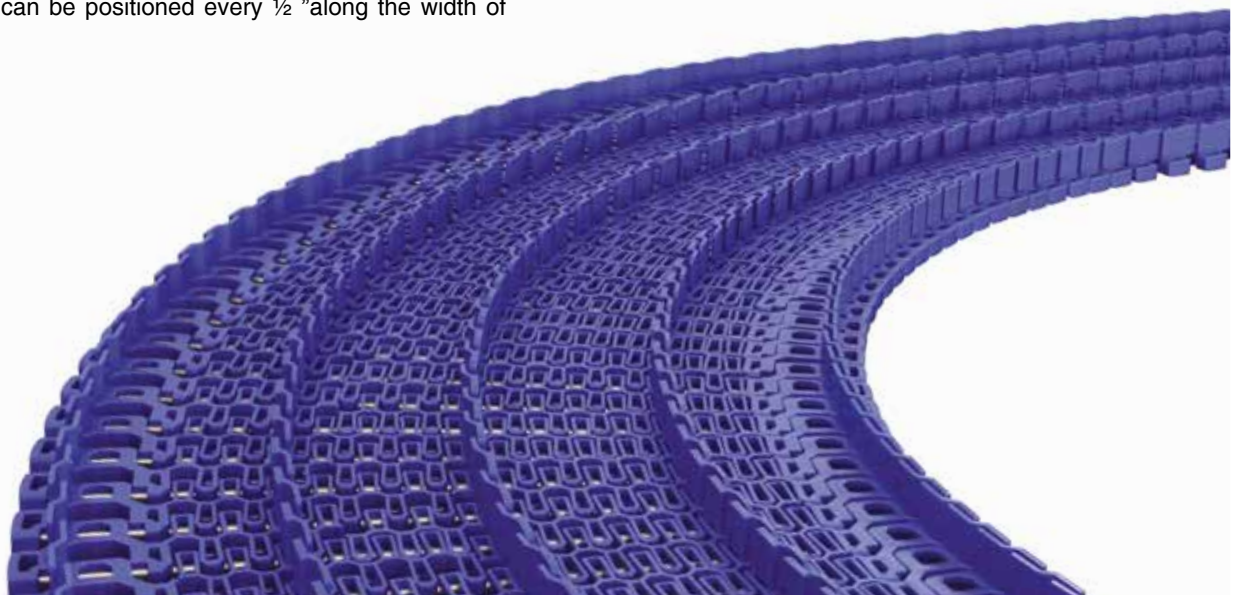

CURVED MODULAR BELTS

TECHNICAL FEATURES

The background of the page is a technical drawing of a cable or pipe system. It features various lines, curves, and annotations. Labels 'L' and 'CC' are visible, along with arrows indicating dimensions and directions. The drawing is rendered in shades of gray and black on a light green background.

Technical features

Technical features

By its construction, the modular belt length varies according to various factors such as tension, temperature and wear. It is therefore not possible to apply tension to the belt by stretching it between fixed shafts.

Belt tension on the drive sprocket is necessary to avoid the belt jumping on the sprocket itself. This tension is obtained by leaving a portion of belt suspended immediately after the sprocket.

This belt portion forms a dip that in addition to providing the return tension (F_{cat}) also allows the recovery of belt elongation between sections.

Values "L" and "S" determine the value of F_{cat} . Values of "S" too small or "L" too large lead to excessive belt tension.

The belt weight and the geometry of the dip determine F_{cat} .

It is also important to ensure that the wrapping angle of the belt on the pinion is between 170° and 210° .

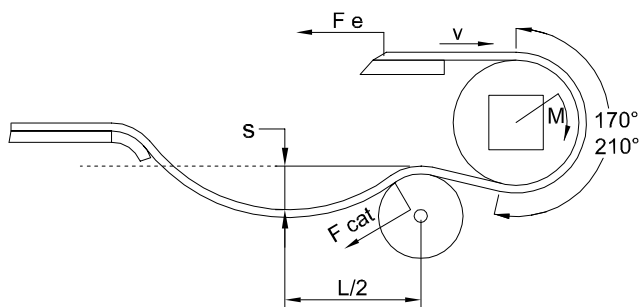

For a correct belt tension that optimizes the belt wear and tear, it is important to verify that the "L" and "S" dimensions are in the following range.

The return path of the belt may be supported in different ways or not supported, depending on the belt length.

S range suggested values [mm]					
L [m]	Belt weight [kg/m ²]				
	4	8	10	12	14
-	20-40	25-60	30-70	40-90	50-100
0,9	25-50	40-90	50-100	60-120	70-130
1,1	30-70	50-100	60-120	70-150	80-160

Horizontal conveyor

Case of max center distance I 2 meters.

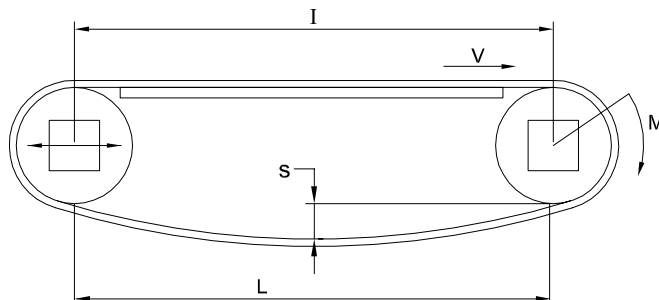

Case of center distance I between 2 and 4 meters.

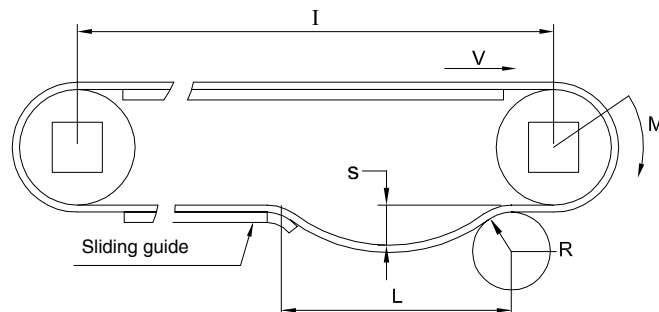

Case of center distance I over 4 meters (if over 20 meters it is suggested a gravity tensioner device after the drive shaft since the belt length variation can be too large to guarantee a correct dip amount).

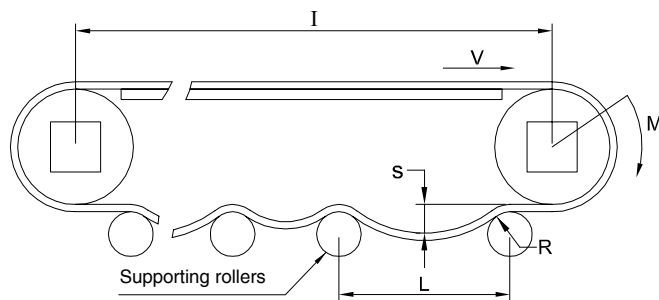

"R" minimum in mm		
Pitch belt	Belt with flights	Belt without flights
1/2"	25	-
1"	25	100
1-1/2"	35	125
2"	50	150

900 <L< 1200 mm

The distances between the support rollers should be alternated between L max and L min.

If the belt has guides, it may be necessary to have an indent for the guides in the return path (if it is needed: l over 2 m). In case of particularly wide strips, it is appropriate to provide the interruption of the flights also in the central part to allow the belt suspension with a further guide.

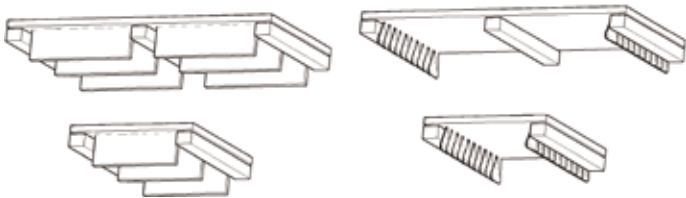

Pitch belt	1/2"	1"	1-1/2"	2"
Max belt width not supported	800	1000	1200	1700

Layout for bi directional conveying

If it is necessary for the conveyor to move in both directions of travel, it is necessary that the drive shaft is located approximately in the middle of the return way and that two catenary sag can be formed on both sides of the Drive shaft just after the rollers.

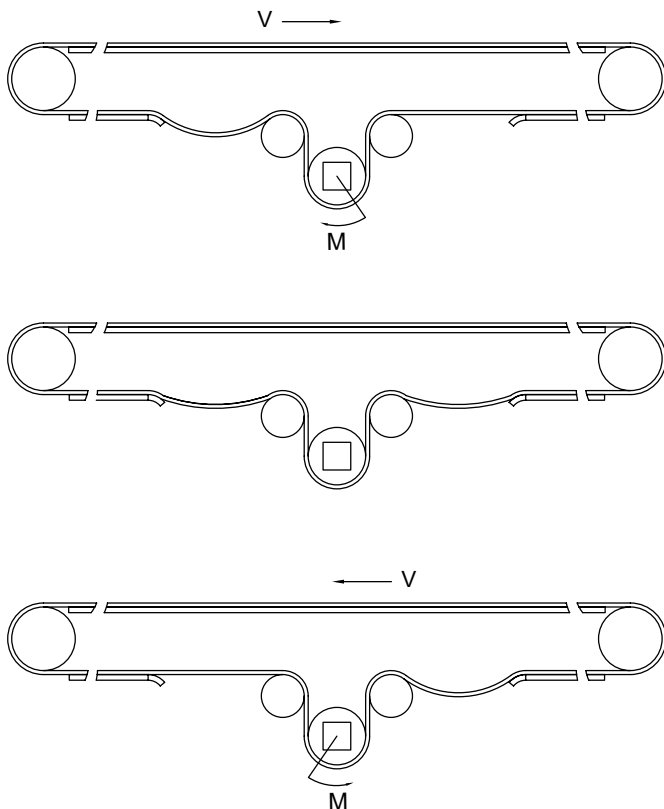

Escalators

For all escalator configurations, the guiding principles are still valid, it is necessary to ensure a minimum tension on the return stroke, a dip sufficient for the belt length variation and able to support the belt on the return stroke.

The position of the dip in most cases should be placed at the base of the escalator, but if the friction of the belt is such that it does not allow it to slide on the return path, the dip will be at the top immediately after the drive shaft.

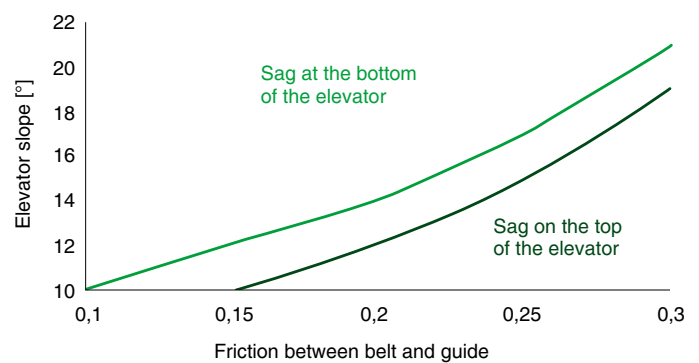
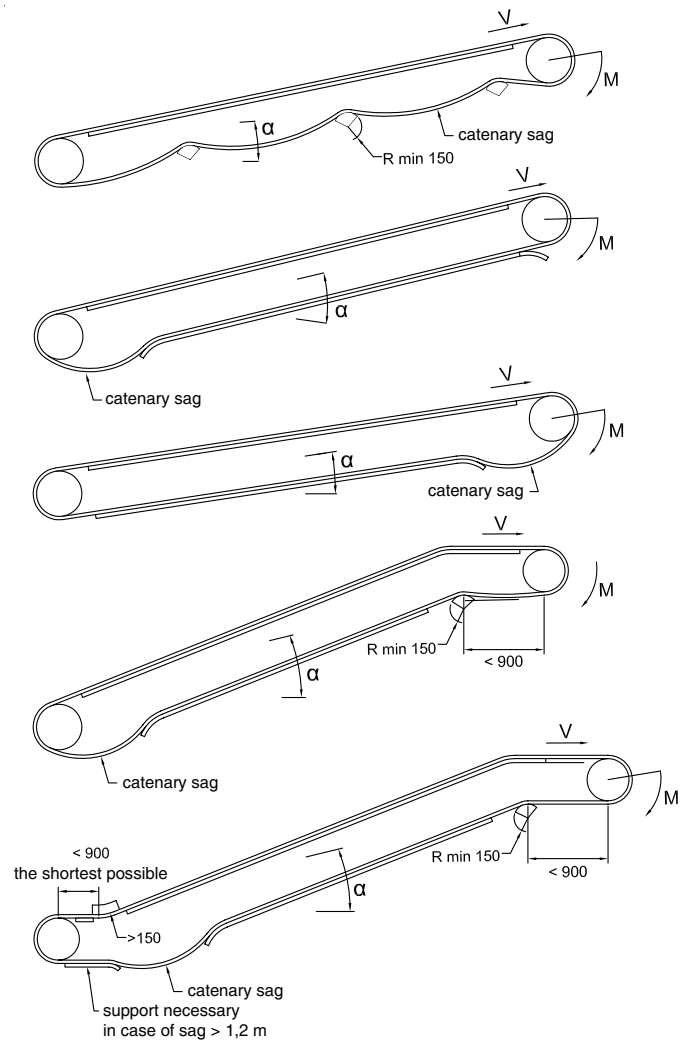

Frequently, belts with guides are used for escalators.

In this case, as with horizontal conveyors, the belt edges must allow space for the guides, and if the width exceeds the width limit values, a central support should also be provided.

In case the belt does have sidewalls, the minimum back bending diameters must be checked (see product dimension sheets).

In the case of lifting with back bending closed to the driven shaft, the horizontal section has to be as short as possible.

Additionally, since it is not possible to support the belt in the area of the guide, it is suggested to limit the belt width as shown in the following table:

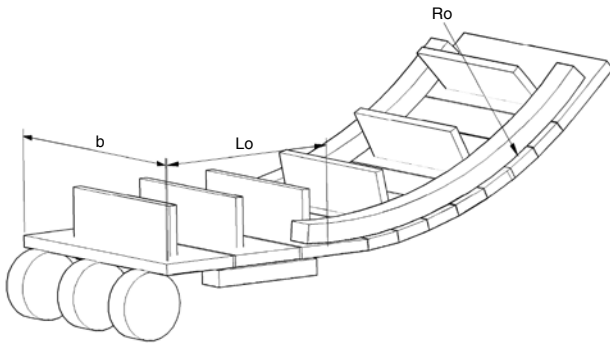

Pitch belt	1/2"				1"			
Belt load	<50%		>50%		<50%		>50%	
Slope Lo [mm]	from 800 to 2000	<800	from 800 to 2000	<800	from 800 to 2000	<800	from 800 to 2000	da 800 a 2000
Width max b [mm]								
Slope <45°	1500	1200	1000	800	1200	1000	800	600
Slope >45°	1050	-	700	-	850	-	550	-

Ro = minimum radius = 150 mm

Pitch belt	1-1/2"				2"			
Belt load	<50%		>50%		<50%		>50%	
Slope Lo [mm]	<800	from 800 to 2000	<800	from 800 to 2000	<800	from 800 to 2000	<800	from 800 to 2000
Width max b [mm]								
Slope <45°	800	600	600	500	700	550	500	400
Slope >45°	550	-	400	-	500	-	300	-

Ro = minimum radius = 150 mm

Tight transfer

For 1/2 "pitch, "sliding bars" can be used to minimize space between two belts or between belt and table. The sliding bar can be placed on one or both ends of the belt.

The back bending roller should be larger than the regular roller support.

In this case, it is also important to ensure the presence of the dip and the contact arc on the sprockets.

Pitch 1/2" - NMEC127 type

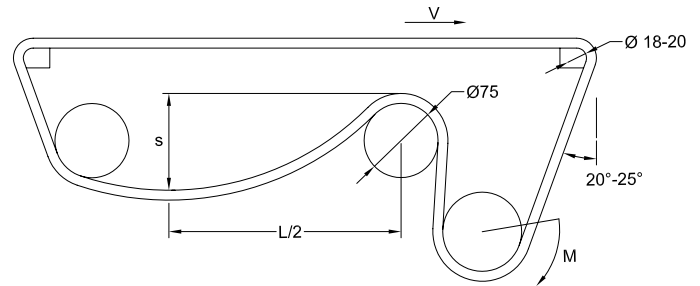

Pitch 8 mm - NMMP80 type

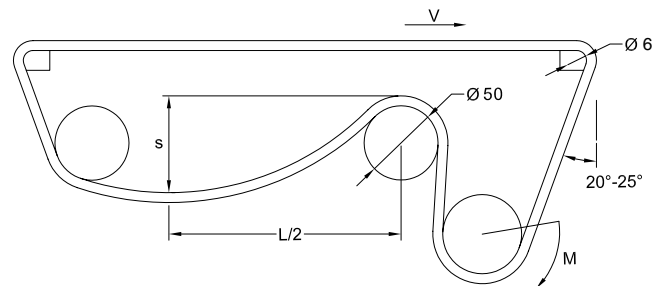

STRAIGHT MODULAR CHAINS

The background of the page is a vertical strip of images showing different types of modular chains. At the top, there are grey metal links. Below that is a white plastic chain with circular links. At the bottom, there is a blue plastic chain with a more complex, interlocking link design. The text 'Straight modular chains' is overlaid on the white chain section.

**Straight
modular chains**

Standard material: POM LF

Delrin Kevlar® material available on request

Pin Material: Stainless Steel AISI 304

Standard delivery length: 80 steps = 3048 mm

Code	Width		Table thickness [mm]	Admissible load [N]	Weight [kg/m]
	[mm]	[inch]			
NCMD820K325-LF	82,5	3,25	4	1400	0,84
NCMD820K400-LF	101,6	4,00	4	1400	0,95
NCMD820K450-LF	114,3	4,50	4	1400	1,05
NCMD820K600-LF	152,4	6,00	4,8	1400	1,30
NCMD820K750-LF	190,5	7,50	4,8	1400	1,55

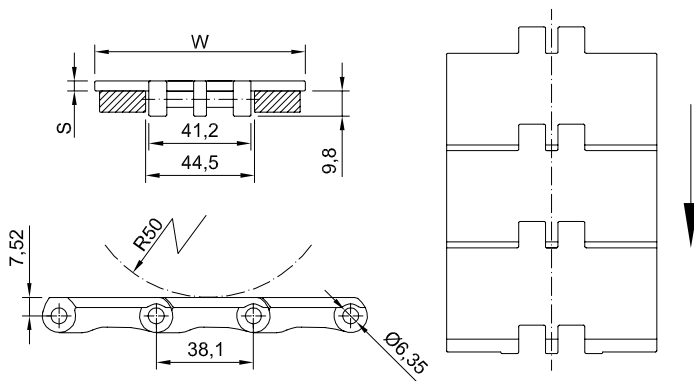
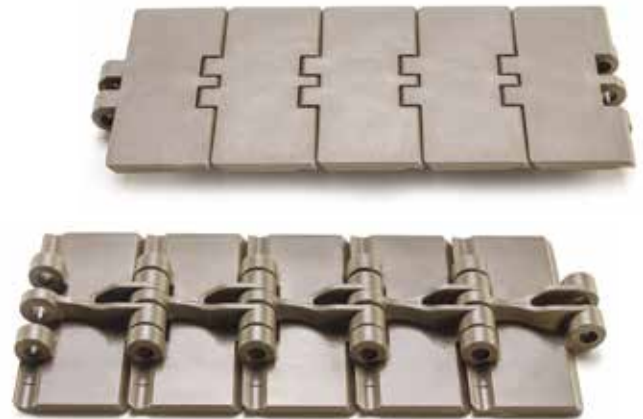

Part number NCMD 820 K325 -LF

Type _____

Pitch _____

Width in inches x 100 _____

Low friction _____

Sprockets for NCMD820 chain



Part number NSMD820 - R 20 Z21

Type _____

Bore type: R = round / Q = square _____

Bore dimension (mm) _____

Teeth nr. _____

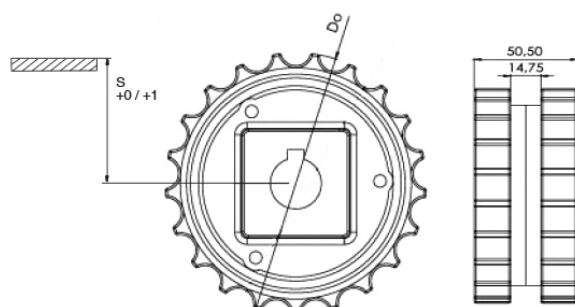

Teeth nr.	Dp [mm]	Do [mm]	S [mm]	Ø round + set-screw UNI
21	129,3	129	67,8	25-30
23	141,2	142	74,8	25-30
25	153,2	154	79,8	25-30

Standard material: nylon PA6 fiberglass.
 It is possible to supply sprocket with any number of teeth or any material by CNC machining
 Dp = Pitch diameter
 Do = External tooth diameter

NCMD821

Standard material: POM LF

Delrin Kevlar® material available on request

Pin Material: Stainless Steel AISI 304

Standard delivery length: 80 steps = 3048 mm

Code	Width		Table thickness [mm]	Admissible load [N]	Weight [kg/m]
	[mm]	[inch]			
NCMD821K750-LF	190,5	7,5	4,8	2700	2,7
NCMD821K1000-LF	254,0	10,0	4,8	2700	3,1
NCMD821K1200-LF	304,8	12,0	4,8	2700	3,4

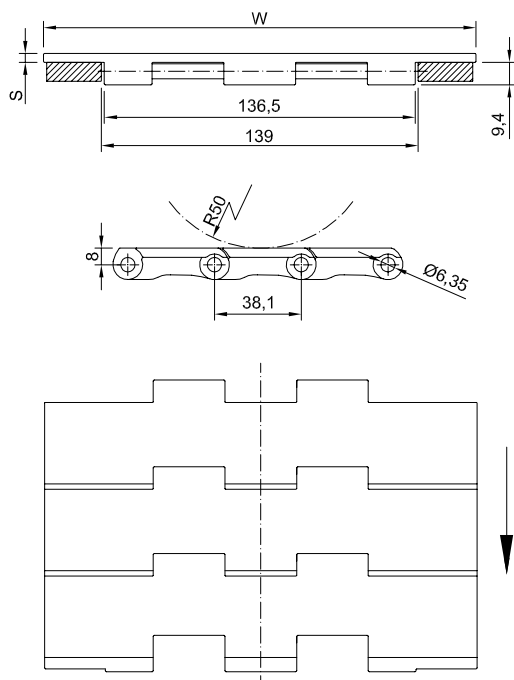

Part number	NCMD	821	K750	-LF
Type				
Pitch				
Width in inches x 100				
Low friction				

Standard material: POM LF
Belt type: closed flat top surface
Pitch: 12,7 mm (1/2")
Nose bar Ø: 20 mm
Width: 50 - 83 - 100 - 150 mm
Standard sprockets: 19 - 24 - 28 - 30 - 36 teeth

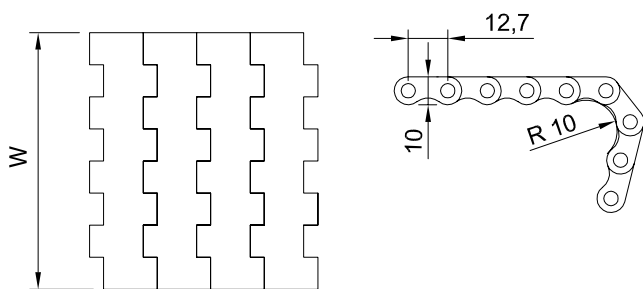

Part number	NCEC	127	C	-B	-83
Type					
Pitch					
Closed flat top surface					
Belt color: B = blue / N = brown					
Width in mm					

Sprockets for NCEC127



Part number	NSEC127 - R	20	Z20
Type			
Bore type: R = round / Q = square			
Bore dimension (mm)			
Teeth nr.			

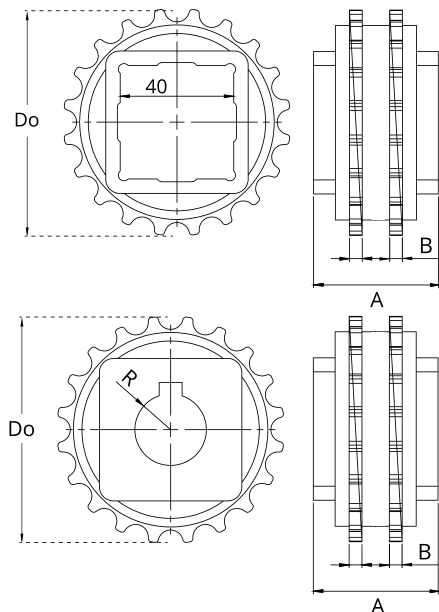

Teeth nr.	Dp [mm]	Do [mm]	A [mm]	B [mm]	Available standard bore	
					Square [mm]	Ø round + set-screw UNI
19	77,3	78,1	40	3,5	40x40	20 - 25 - 30
24	97,6	99,0	40	3,5	40x40	20 - 25 - 30
28	113,9	115,3	40	3,5	40x40	25 - 30
30	122,0	123,4	40	3,5	40x40	25 - 30
36	146,4	147,9	40	3,5	40x40	25 - 30

Standard material: nylon PA6 fiberglass.
 It is possible to supply sprocket with any number of teeth or any material by CNC machining
 Dp = Pitch diameter
 Do = External tooth diameter

NCEC127FG

Standard material: POM LF
Belt type: open flat surface flush grid
Pitch: 12,7 mm (1/2")
Nose bar Ø: 20 mm
Width: 50 - 83 - 100 - 150 mm
Standard sprockets: 19 - 24 - 28 - 30 - 36 teeth

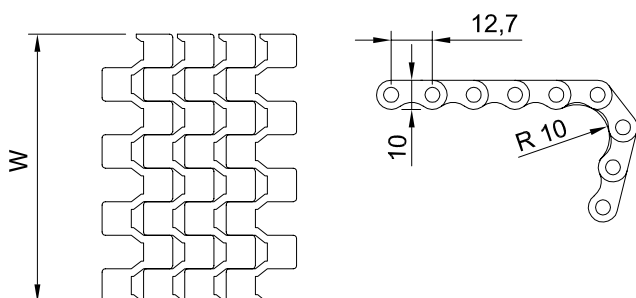
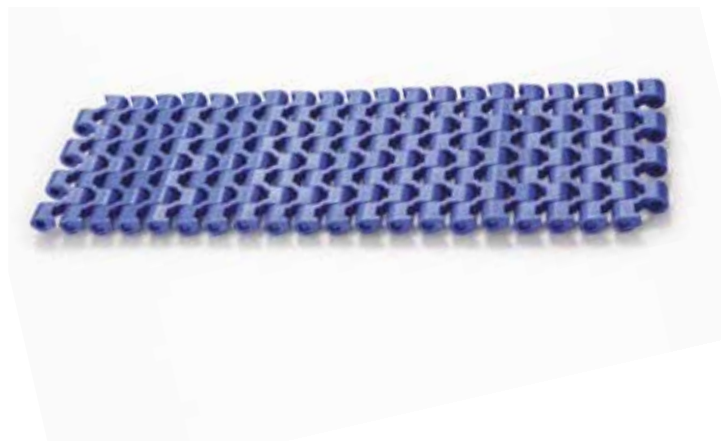

Part number	NCEC	127	FG	-B	-83
Type					
Pitch					
Open flat surface flush grid					
Belt color: B = blue / N = brown					
Width in mm					

Sprockets for NCEC127



Part number	NSEC127	- R	20	Z20
Type				
Bore type: R = round / Q = square				
Bore dimension (mm)				
Teeth nr.				

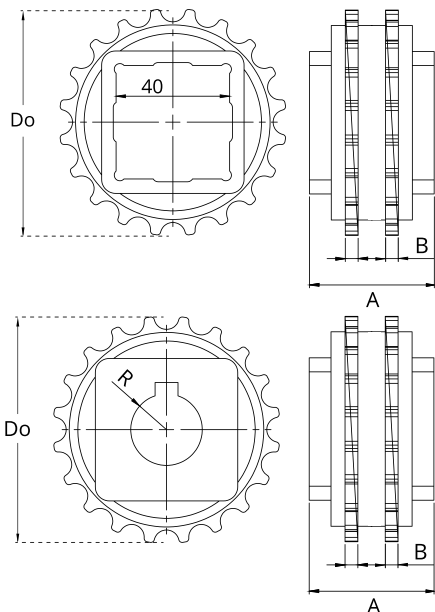

Teeth nr.	Dp [mm]	Do [mm]	A [mm]	B [mm]	Available standard bore	
					Square [mm]	Ø round + set-screw UNI
19	77,3	78,1	40	3,5	40x40	20 - 25 - 30
24	97,6	99,0	40	3,5	40x40	20 - 25 - 30
28	113,9	115,3	40	3,5	40x40	25 - 30
30	122,0	123,4	40	3,5	40x40	25 - 30
36	146,4	147,9	40	3,5	40x40	25 - 30

Standard material: nylon PA6 fiberglass.
 It is possible to supply sprocket with any number of teeth or any material by CNC machining
 Dp = Pitch diameter
 Do = External tooth diameter

STRAIGHT MODULAR CHAINS

Standard material: POM
Belt type: open flat surface flush grid
Pitch: 25,4 mm (1")
Width: 100 mm
Standard sprocket: 8, 10, 12, 15, 18 teeth

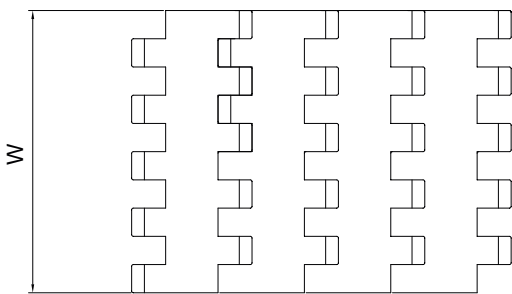

Part number	NCMD 254 C -B -100
Type	
Pitch	
Closed flat top surface	
Belt color: B = blue / W = white	
Width in mm	

Sprockets for NCMD254



Part number	NSMD254 - Q 40 -Z12
Type	
Bore type: R = round / Q = square	
Bore dimension (mm)	
Teeth nr.	

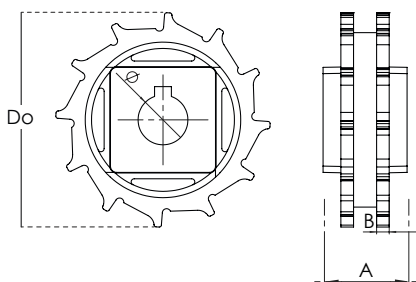
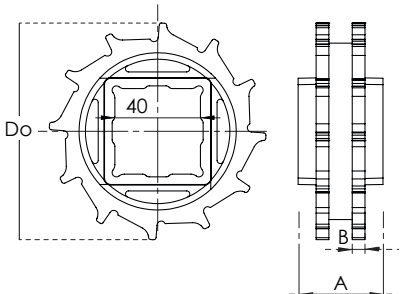

Teeth nr.	Dp [mm]	Do [mm]	A [mm]	B [mm]	Available standard bore	
					Square [mm]	Ø round + set-screw UNI
8	68,4	67,7	30	6	25x25	25
10	82,8	85,0	30	6	40x40	25 - 30
12	98,9	102,0	30	6	40x40	25 - 30
15	123,1	126,0	30	6,0	40x40	25 - 30
18	147,4	152,0	30	6	40x40	25 - 30

Standard material: nylon PA6 fiberglass.
 It is possible to supply sprocket with any number of teeth or any material by CNC machining
 Dp = Pitch diameter
 Do = External tooth diameter

NCMD254FG

Standard material: POM
Belt type: closed flat top surface
Pitch: 25,4 mm (1")
Width: 100 mm
Standard sprocket: 8, 10, 12, 15, 18 teeth

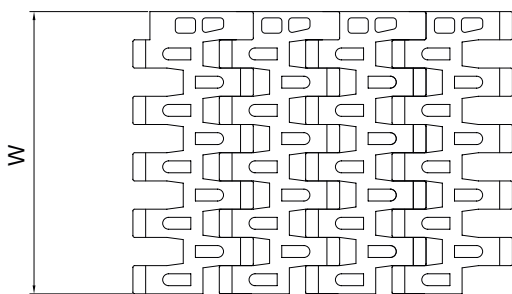

Part number	NCMD	100	FG	-B	-100
Type					
Pitch					
Open flat surface flush grid					
Belt color: B = blue / W = white					
Width in mm					

Sprockets for NCMD254



Part number	NSMD254	- Q	40	-Z12
Type				
Bore type: R = round / Q = Square				
Bore dimension (mm)				
Teeth nr.				

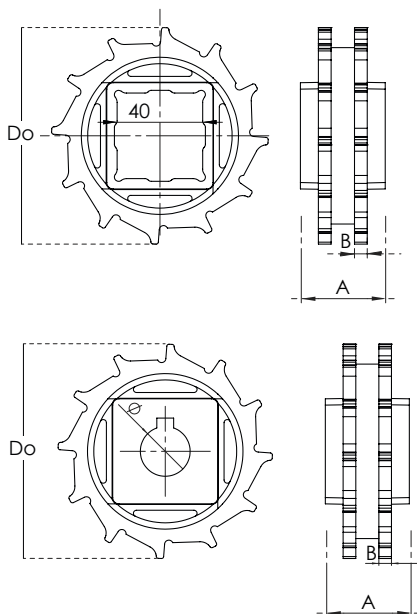

Teeth nr.	Dp [mm]	Do [mm]	A [mm]	B [mm]	Available standard bore	
					Square [mm]	Ø round + set-screw UNI
8	68,4	67,7	30	6	25x25	25
10	82,8	85,0	30	6	40x40	25 - 30
12	98,9	102,0	30	6	40x40	25 - 30
15	123,1	126,0	30	6	40x40	25 - 30
18	147,4	152,0	30	6	40x40	25 - 30

*Standard material: nylon PA6 fiberglass.
 It is possible to supply sprocket with any number of teeth or any material by CNC machining
 Dp = Pitch diameter
 Do = External tooth diameter*

STRAIGHT MODULAR CHAINS

NCMD600-S - NCMD600TAB-S

Standard material: POM LF
Pin Material: Stainless Steel AISI 304
Pignoni standard: 8, 40 teeth
Width con TAB: 54 mm
Spessore della catena: 32 mm

Code	Pitch [mm]	Width		Admissible load [N]	Weight [kg/m]
		[mm]	[inch]		
NCMD600-S	63,5	43,0	1,70	400	1,55
NCMD600TAB-S	63,5	43,0	1,70	400	1,65

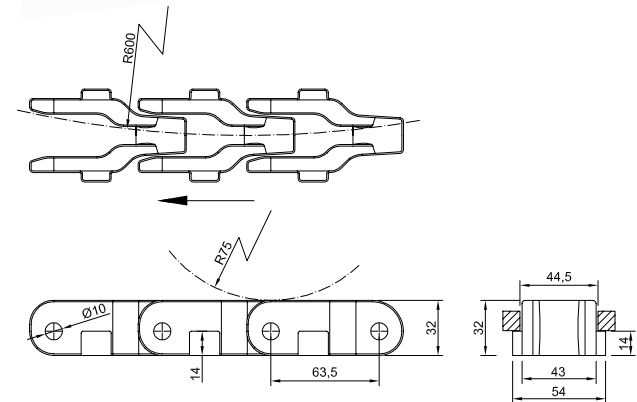
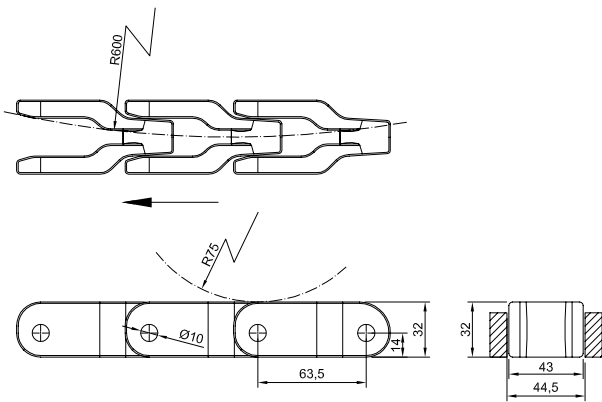

Part number NCMD 600-S

Type _____

Dimension _____

Part number NCMD 600TAB-S

Type _____

Dimension - TAB execution _____

Pignoni per la catena NCMD600

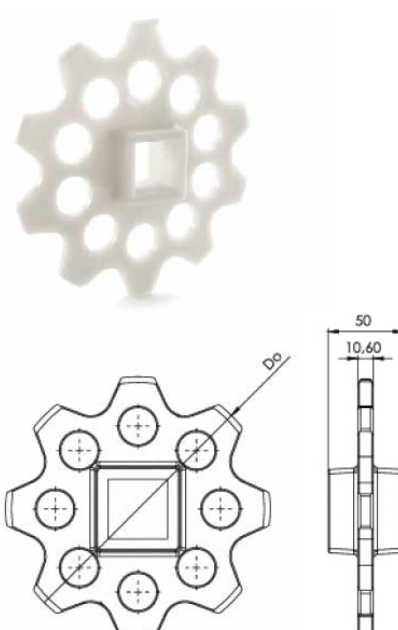

Part number NSMD600 - R 20 Z10

Type _____

Bore type: R = round / Q = square _____

Bore dimension (mm) _____

Teeth nr. _____

Teeth nr.	Dp [mm]	Do [mm]	Available standard bore	
			Square [mm]	Ø round + set-screw UNI
8	166	172	40x40	25-30
10	205	215	40x40	25-30

Standard material: nylon PA6 fiberglass.
 It is possible to supply sprocket with any number of teeth or any material by CNC machining
 Dp = Pitch diameter
 Do = External tooth diameter

CURVED MODULAR CHAINS



Curved modular chains



Standard material: POM LF

Delrin Kevlar® material available on request

Pin Material: Stainless Steel AISI 304

Standard delivery length: 80 steps = 3048 mm

Code	Width		Radius of curvature [mm]	Table thickness [mm]	Admissible load [N]	Weight [kg/m]
	[mm]	[inch]				
NCMD880K325-LF	82,5	3,25	400	4,0	2000	0,9
NCMD880K400-LF	101,6	4,00	400	4,0	2000	1,0
NCMD880K450-LF	114,3	4,50	400	4,0	2000	1,1
NCMD879K600-LF	152,4	6,00	400	4,8	2200	1,3
NCMD879K750-LF	190,5	7,50	400	4,8	2200	1,5

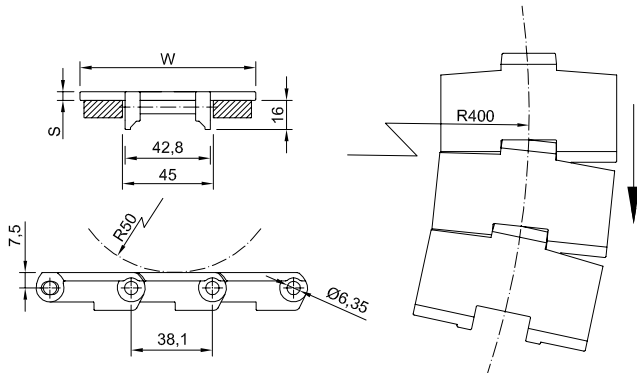

Part number

NCMD 880 K325 -LF

Type

Pitch

Width in inches x 100

Low friction

Sprockets for NCMD880 and NCMD879 chains

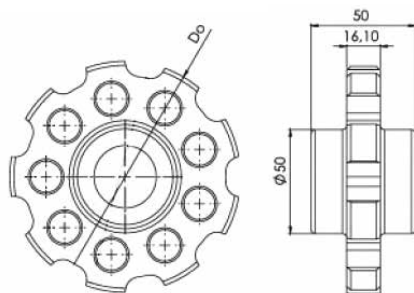

Part number

NSMD880 - R 20 Z11

Type

Bore type: R = round / Q = square

Bore dimension (mm)

Teeth nr.

Teeth nr.	Dp [mm]	Do [mm]	S [mm]	Ø round + set-screw UNI
9	111,4	110	59,3	20-25-30
11	135,2	135	71,2	20-25-30

Standard material: nylon PA6 fiberglass.

It is possible to supply sprocket with any number of teeth or any material by CNC machining

Dp = Pitch diameter

Do = External tooth diameter

NCMD880TAB - NCMD879TAB

Standard material: POM LF

Delrin Kevlar® material available on request

Pin Material: Stainless Steel AISI 304

Standard delivery length: 80 steps = 3048 mm

Code	Width		Radius of curvature [mm]	Table thickness [mm]	Admissible load [N]	Weight [kg/m]
	[mm]	[inch]				
NCMD880K325-TAB	82,5	3,25	400	4,0	2000	0,95
NCMD880K400-TAB	101,6	4,00	400	4,0	2000	1,05
NCMD880K450-TAB	114,3	4,50	400	4,0	2000	1,15
NCMD879K600-TAB	152,4	6,00	400	4,8	2200	1,35
NCMD879K750-TAB	190,5	7,50	400	4,8	2200	1,55

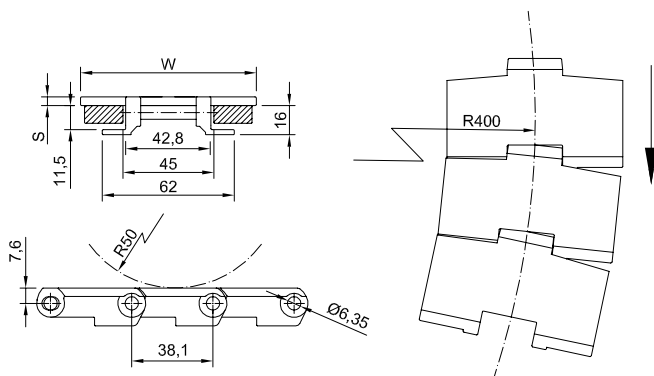

Part number NCMD880 K325 -TAB

Dimension _____

Width in inches x 100 _____

TAB execution _____

Sprockets for NCMD880TAB and NCMD879TAB chains

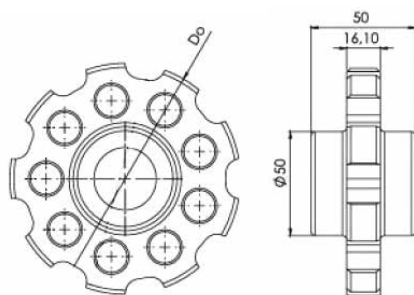

Part number NSMD880 - R 20 Z11

Type _____

Bore type: R = round / Q = square _____

Bore dimension (mm) _____

Teeth nr. _____

Teeth nr.	Dp [mm]	Do [mm]	Available standard bore	
			Square [mm]	Ø round + set-screw UNI
9	111,4	110	40x40	20-25-30
11	135,2	135	40x40	20-25-30

Standard material: nylon PA6 fiberglass.
 It is possible to supply sprocket with any number of teeth or any material by CNC machining
 Dp = Pitch diameter
 Do = External tooth diameter

Standard material: POM LF

Delrin Kevlar® material available on request

Pin Material: Stainless Steel AISI 304

Standard sprockets: 8, 10 teeth

Width: 55 mm

Code	Pitch [mm]	Width		Radius of curvature [mm]	Admissible load [N]	Weight [kg/m]
		[mm]	[inch]			
NCMD1701-R	50	52,5	2,05	150	2550	1,58

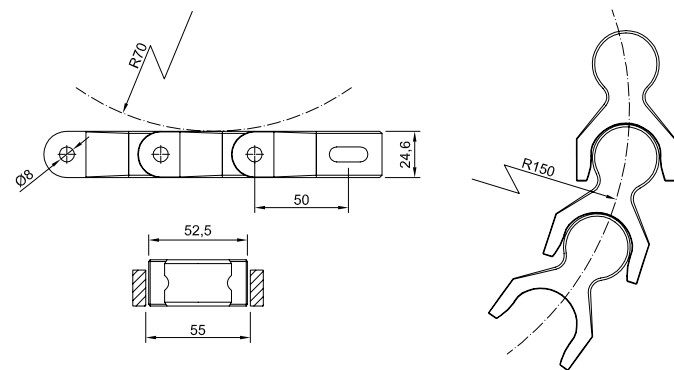

Part number	NCMD 1701-R
Type	
Pitch	

Sprockets for NCMD1701 chain



Part number	NSMD1701 - R 20 Z10
Type	
Bore type: R = round / Q = square	
Bore dimension (mm)	
Teeth nr.	

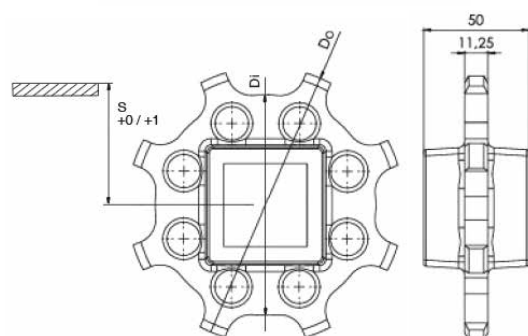

Teeth nr.	Di [mm]	Do [mm]	S [mm]	Available standard bore	
				Square [mm]	Ø round + set-screw UNI
8	106,8	136	53	40x40	25-30
10	136,8	165	69	40x40	25-30

Standard material: nylon PA6 fiberglass.

It is possible to supply sprocket with any number of teeth or any material by CNC machining

Dp = Pitch diameter

Do = External tooth diameter

NCMD1701TAB-R

Standard material: POM LF

Delrin Kevlar® material available on request

Pin Material: Stainless Steel AISI 304

Standard sprockets: 8, 10 teeth

Width with TAB: 66,5 mm

Code	Pitch [mm]	Width		Radius of curvature [mm]	Admissible load [N]	Weight [kg/m]
		[mm]	[inch]			
NCMD1701TAB-R	50	52,5	2,05	150	2550	1,65

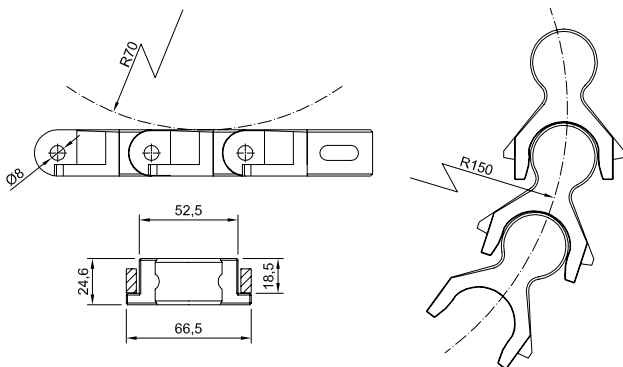

Part number	NCMD 1701-TAB-R
Type	
Dimension - TAB execution	

Sprockets for NCMD1701 chain



Part number	NSMD1701 - R 20 Z10
Type	
Bore type: R = round / Q = square	
Bore dimension (mm)	
Teeth nr.	

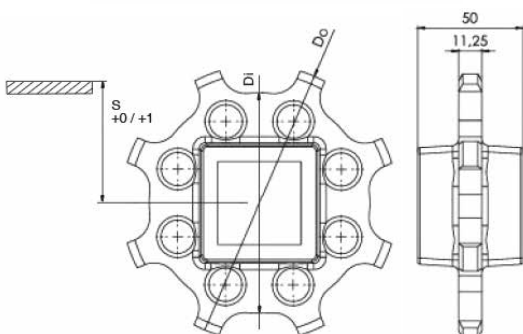

Teeth nr.	Di [mm]	Do [mm]	S [mm]	Available standard bore	
				Square [mm]	Ø round + set-screw UNI
8	106,8	136	53	40x40	25-30
10	136,8	165	69	40x40	25-30

Standard material: nylon PA6 fiberglass.
 It is possible to supply sprocket with any number of teeth or any material by CNC machining
 Dp = Pitch diameter
 Do = External tooth diameter

CURVED MODULAR CHAINS

Standard material: POM LF

Delrin Kevlar® material available on request

Pitch: 33,5 mm

Pin Material: Stainless Steel AISI 304

Standard sprockets: 12 teeth

Code	Width		Radius of curvature [mm]	Table thickness [mm]	Admissible load [N]	Weight [kg/m]
	[mm]	[inch]				
NCFLEXI-LF	82,5	3,25	140	4	1100	1,25
	114,3	4,50	160	4	1100	1,55

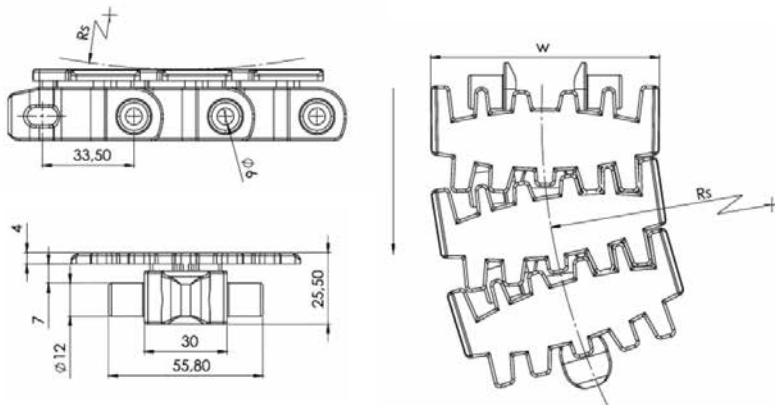

Part number **NCFLEXI -K325 -LF**

Type _____

Width in inches x 100 _____

Materiale: POM LF _____

Sprockets for FLEXI chain

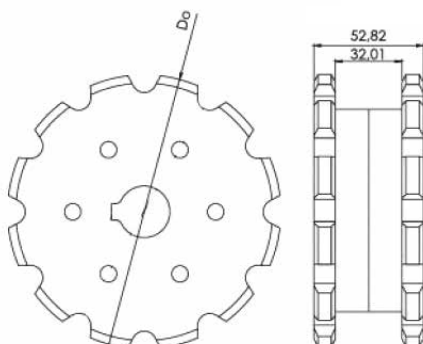

Part number **NSFLEXI - R 20 Z12**

Type _____

Bore type: R = round / Q = square _____

Bore dimension (mm) _____

Teeth nr. _____

Teeth nr.	Dp [mm]	Do [mm]	Available standard bore	
			Square [mm]	Ø round + set-screw UNI
12	131	133	40x40	25-30

Standard material: nylon PA6 fiberglass.
 It is possible to supply sprocket with any number of teeth or any material by CNC machining
 Dp = Pitch diameter
 Do = External tooth diameter

CLAMP FOR SPROCKETS



Clamp for sprockets



Clamp for sprockets

Clamp with round bore



D Bore + set screw UNI [mm]	Diameter external A [mm]	Height B [mm]	Thickness C [mm]	Material	Data and screw
25	44	43	14	PA + fiberglass	AISI304

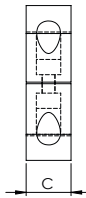
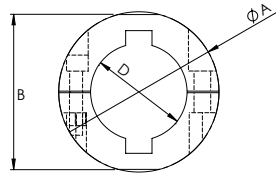

Part number **N-CLAMP - R 25**

Clamp _____

Bore type: R = round _____

Bore dimension (mm) _____



D Bore + set screw UNI [mm]	Diameter external A [mm]	Height B [mm]	Thickness C [mm]	Material	Data and screw
30	50	48	14	PA + fiberglass	AISI304

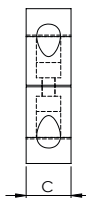
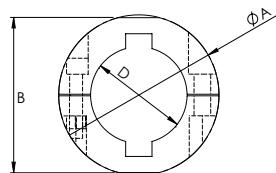

Part number **N-CLAMP - R 30**

Clamp _____

Bore type: R = round _____

Bore dimension (mm) _____

Clamp with square bore



D [mm]	Diameter external A [mm]	Height B [mm]	Thickness C [mm]	Material	Data and screw
40x40	67,5	60	16	PA + fiberglass	AISI304

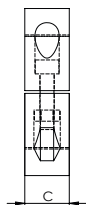
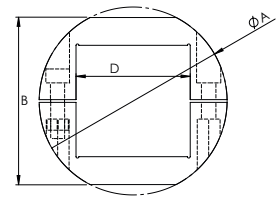

Part number **N-CLAMP - Q 40**

Clamp _____

Bore type: Q = square _____

Bore dimension (mm) _____



D [mm]	Diameter external A [mm]	Height B [mm]	Thickness C [mm]	Material	Data and screw
60x60	100,5	84	16	PA + fiberglass	AISI304

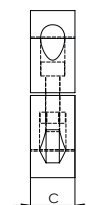
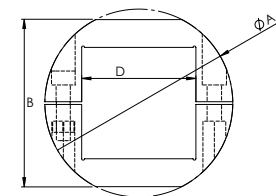

Part number **N-CLAMP - Q 60**

Clamp _____

Bore type: Q = square _____

Bore dimension (mm) _____

NOTE:

A series of horizontal dotted lines for writing notes.

NOTE:

A series of horizontal dotted lines for writing notes.

In accordance with the SIT S.p.A. policy, for a constant improvement of our products, technical data contained in this catalog may be changed without notice.

SIT S.p.A. DOES NOT supply products for applications within the following markets: Aeronautical sector, Nuclear sector, Aerospace sector and Off-shore sector. SIT products are specifically designed for the industrial sector; therefore SIT does not assume any responsibility for the use of its products in the above mentioned sectors, being applications that require different safety factors from those of the industrial use for which they have been designed.



SIT S.p.A.
Viale A. Volta, 2
20090 Cusago (MI) - Italy
Tel. +39 02 89144 1
Fax +39 02 89144 293
export@sitspa.it
www.sitspa.com

Factory
Via G. Carminati, 15
24012 Val Brembilla (BG) - Italy

AUTHORIZED DISTRIBUTOR

SIT GERMANY

SIT ANTRIEBSELEMENTE GmbH
Rieseler Feld 9 (Gewerbegebiet West)
D - 33034 Brakel
Tel. +49 52 72 39 28 0
Fax +49 52 72 39 28 90
E-mail: info@sit-antriebselemente.de
Web: www.sit-antriebselemente.de

SIT SWITZERLAND

SIT (Schweiz) AG
Lenzbüel 13
CH - 8370 Sirmach
Tel. +41 71 969 50 00
Fax +41 71 969 50 01
E-mail: info@sit-antriebstechnik.ch
Web: www.sit-antriebstechnik.ch

SIT SPAIN

DINAMICA DISTRIBUCIONES S.A.
Ctra. N-II, Km 592,6
E - 08740 S. Andreu De La Barca
(Barcelona)
Tel. +34 93 653 35 00
Fax +34 93 653 35 08
E-mail: dinamica@dinamica.net
Web: www.dinamica.net

SIT FRANCE

FOGEX SAS
215, Rue Henri Barbusse
F - 95100 Argenteuil
Tel. +33 1 34 34 46 00
Fax +33 1 34 34 46 01
E-mail: info@fogex.com
Web: www.fogex.com

SIT USA

S.I.T. INDEVA, Inc.
3630 Green Park Circle
NC - 28217 Charlotte
Tel. +1 704 357 8811
Fax +1 704 357 8866
E-mail: info@sit-indeva.com
Web: www.sit-indeva.com

SIT CHINA

SIT INDEVA (SHANGHAI) LTD.
Building 2, 269 YuanZhong Road
Nanhui Industrial park
Pudong new area
PRC - 201300 Shanghai
Tel. +86 021 5108 2206
Fax +86 021 6486 3511
E-mail: info@sit-shanghai.com
Web: www.sit-shanghai.com

SIT INDIA

SIT PTC INDIA PVT. LTD.
Plot no. 677, s.no. 269/3
Paud Road, Bhugao
Taluka - Mulshi - Pune - 412 115
Maharashtra - India
Tel. +91 9158 5921 11
E-mail: a.nangre@sitspa.com
Web: www.sitspa.com