

Standard material: POM LF

Delrin Kevlar® material available on request

Pin Material: Stainless Steel AISI 304

Standard delivery length: 80 steps = 3048 mm

Code	Width		Radius of curvature [mm]	Table thickness [mm]	Admissible load [N]	Weight [kg/m]
	[mm]	[inch]				
NCMD880K325-LF	82,5	3,25	400	4	2000	0,90
NCMD880K400-LF	101,6	4,00	400	4	2000	1,00
NCMD880K450-LF	114,3	4,50	400	4	2000	1,10
NCMD879K600-LF	152,4	6,00	400	4,8	2200	1,30
NCMD879K750-LF	190,5	7,50	400	4,8	2200	1,50

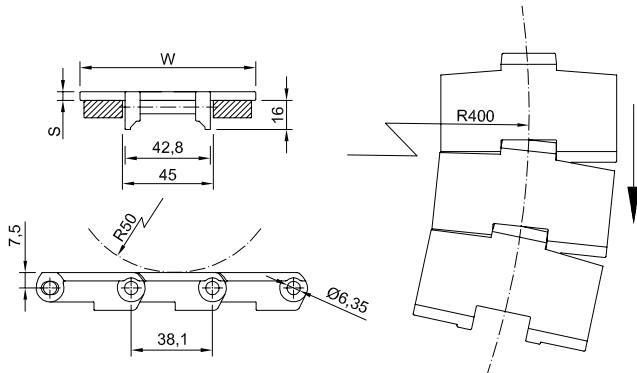

Part number NCMD 880 K325 -LF

Type _____

Pitch _____

Width in inches x 100 _____

Low friction _____

SPROCKETS for the series NCMD880 e NCMD879

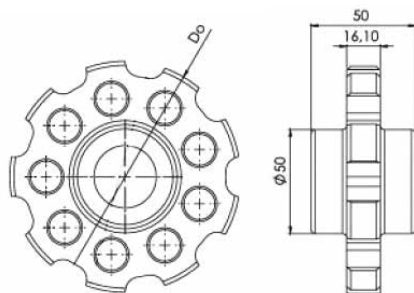

Part number NSMD880 - R 20 Z11

Type _____

Hole type: R = round / Q = square _____

Hole size (mm) _____

Number of teeth _____

Teeth nr.	Dp [mm]	Do [mm]	S [mm]	Ø round + set-screw UNI
9	111,4	110	59,3	20-25-30
11	135,2	135	71,2	20-25-30

Standard material: nylon PA6 fiberglass.

It is possible to supply sprocket with any number of teeth or any material by CNC machining

Dp = Pitch diameter

Do = External tooth diameter

NCMD880TAB - NCMD879TAB

Standard material: POM LF

Delrin Kevlar® material available on request

Pin Material: Stainless Steel AISI 304

Standard delivery length: 80 steps = 3048 mm

Code	Width		Radius of curvature [mm]	Table thickness [mm]	Admissible load [N]	Weight [kg/m]
	[mm]	[inch]				
NCMD880K325-TAB	82.5	3.25	400	4	2000	0.95
NCMD880K400-TAB	101.6	4.00	400	4	2000	1.05
NCMD880K450-TAB	114.3	4.50	400	4	2000	1.15
NCMD879K600-TAB	152.4	6.00	400	4.8	2200	1.35
NCMD879K750-TAB	190.5	7.50	400	4.8	2200	1.55

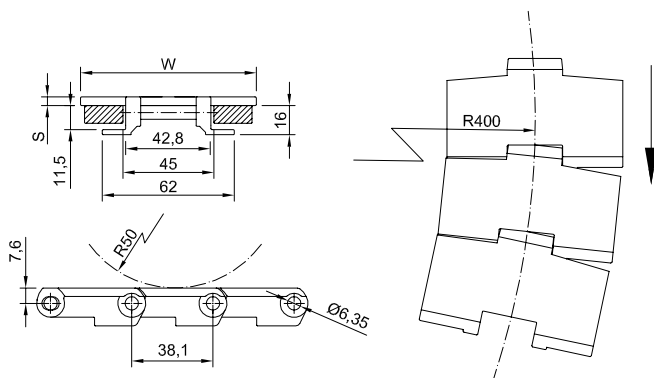

Part number NCMD880 K325 -TAB

Dimension

Width in inches x 100

TAB execution

SPROCKES for the series NCMD880TAB e NCMD879TAB

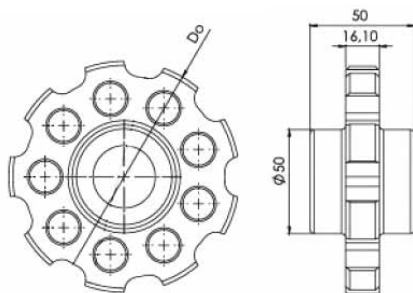

Part number NSMD880 - R 20 Z11

Type

Hole type: R = round / Q = square

Hole size (mm)

Number of teeth

Teeth nr.	Dp [mm]	Do [mm]	Available standard holes	
			Square [mm]	Ø round + set-screw UNI
9	111,4	110	40x40	20-25-30
11	135,2	135	40x40	20-25-30

Standard material: nylon PA6 fiberglass.
 It is possible to supply sprocket with any number of teeth or any material by CNC machining
 Dp = Pitch diameter
 Do = External tooth diameter

Standard material: POM LF

Delrin Kevlar® material available on request

Pin Material: Stainless Steel AISI 304

Standard sprockets: 8, 10 teeth

Width: 55 mm

Code	Pitch [mm]	Width		Radius of curvature [mm]	Admissible load [N]	Weight [kg/m]
		[mm]	[inch]			
NCMD1701-R	50	52,5	2,05	150	2550	1,58

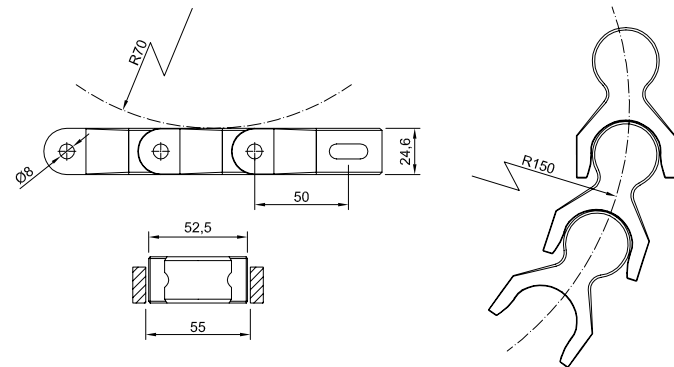

Part number	NCMD 1701-R
Type	
Pitch	

SPROCKES for the series NCMD1701-R



Part number	NSMD1701 - R 20 Z10
Type	
Hole type: R = round / Q = square	
Hole size (mm)	
Number of teeth	

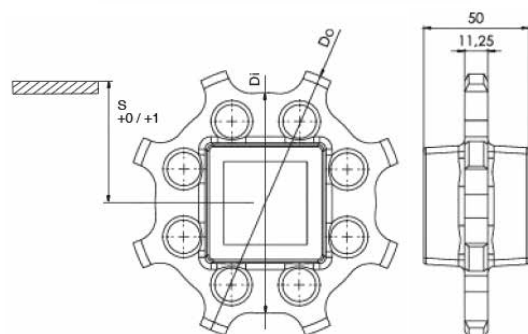

Teeth nr.	Di [mm]	Do [mm]	S [mm]	Available standard holes	
				Square [mm]	Ø round + set-screw UNI
8	106,8	136	53	40x40	25-30
10	136,8	165	69	40x40	25-30

Standard material: nylon PA6 fiberglass.
 It is possible to supply sprocket with any number of teeth or any material by CNC machining
 Dp = Pitch diameter
 Do = External tooth diameter

NCMD1701TAB-R

Standard material: POM LF

Delrin Kevlar® material available on request

Pin Material: Stainless Steel AISI 304

Standard sprockets: 8, 10 teeth

Width with TAB: 66,5 mm

Code	Pitch [mm]	Width		Radius of curvature [mm]	Admissible load [N]	Weight [kg/m]
		[mm]	[inch]			
NCMD1701TAB-R	50	52,5	2,05	150	2550	1,65

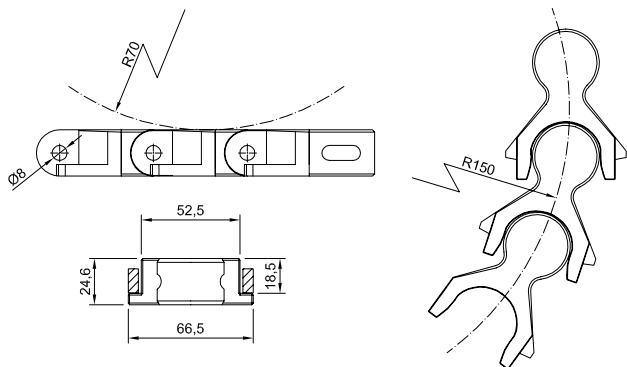

Part number	NCMD 1701-TAB-R
Type	
Dimension - TAB execution	

SPROCKES for the series NCMD1701-R



Part number	NSMD1701 - R 20 Z10
Type	
Hole type: R = round / Q = square	
Hole size (mm)	
Number of teeth	

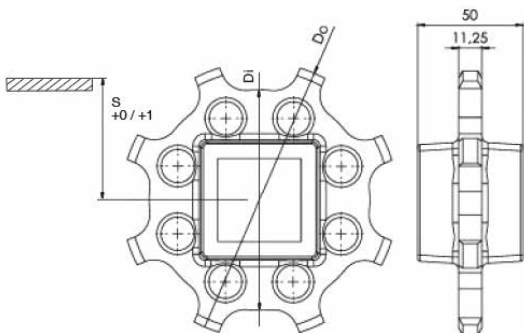

Teeth nr.	Di [mm]	Do [mm]	S [mm]	Available standard holes	
				Square [mm]	Ø round + set-screw UNI
8	106,8	136	53	40x40	25-30
10	136,8	165	69	40x40	25-30

Standard material: nylon PA6 fiberglass.
 It is possible to supply sprocket with any number of teeth or any material by CNC machining
 Dp = Pitch diameter
 Do = External tooth diameter

CURVED MODULAR CHAINS

Standard material: POM LF

Delrin Kevlar® material available on request

Pitch: 33,5 mm

Pin Material: Stainless Steel AISI 304

Standard sprockets: 12 teeth

Code	Width		Radius of curvature [mm]	Table thickness [mm]	Admissible load [N]	Weight [kg/m]
	[mm]	[inch]				
NCFLEXI-LF	82,5	3,25	140	4	1100	1,25
	114,3	4,50	160	4	1100	1,55

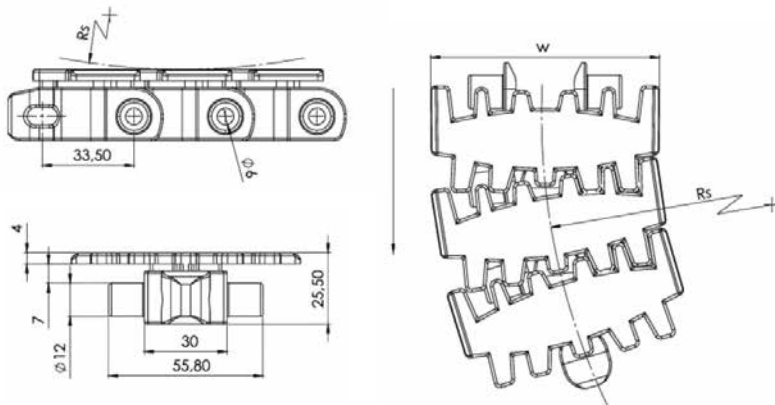

Part number **NCFLEXI -K325 -LF**

Type _____

Width in inches x 100 _____

Material: POM LF _____

SPROCKES for the series FLEXI

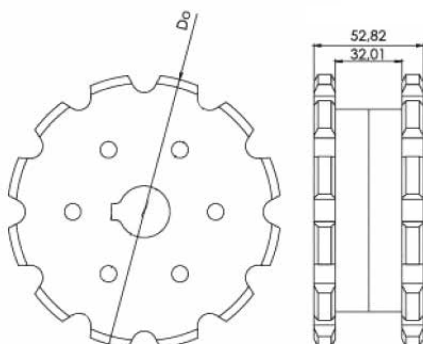

Part number **NSFLEXI - R 20 Z12**

Type _____

Hole type: R = round / Q = square _____

Hole size (mm) _____

Number of teeth _____

Teeth nr.	Dp [mm]	Do [mm]	Available standard holes	
			Square [mm]	Ø round + set-screw UNI
12	131	133	40x40	25-30

Standard material: nylon PA6 fiberglass.
 It is possible to supply sprocket with any number of teeth or any material by CNC machining
 Dp = Pitch diameter
 Do = External tooth diameter