

CG Series

Superior Rolling Moment with Cover Strip

(2) CGL-CA / CGL-HA

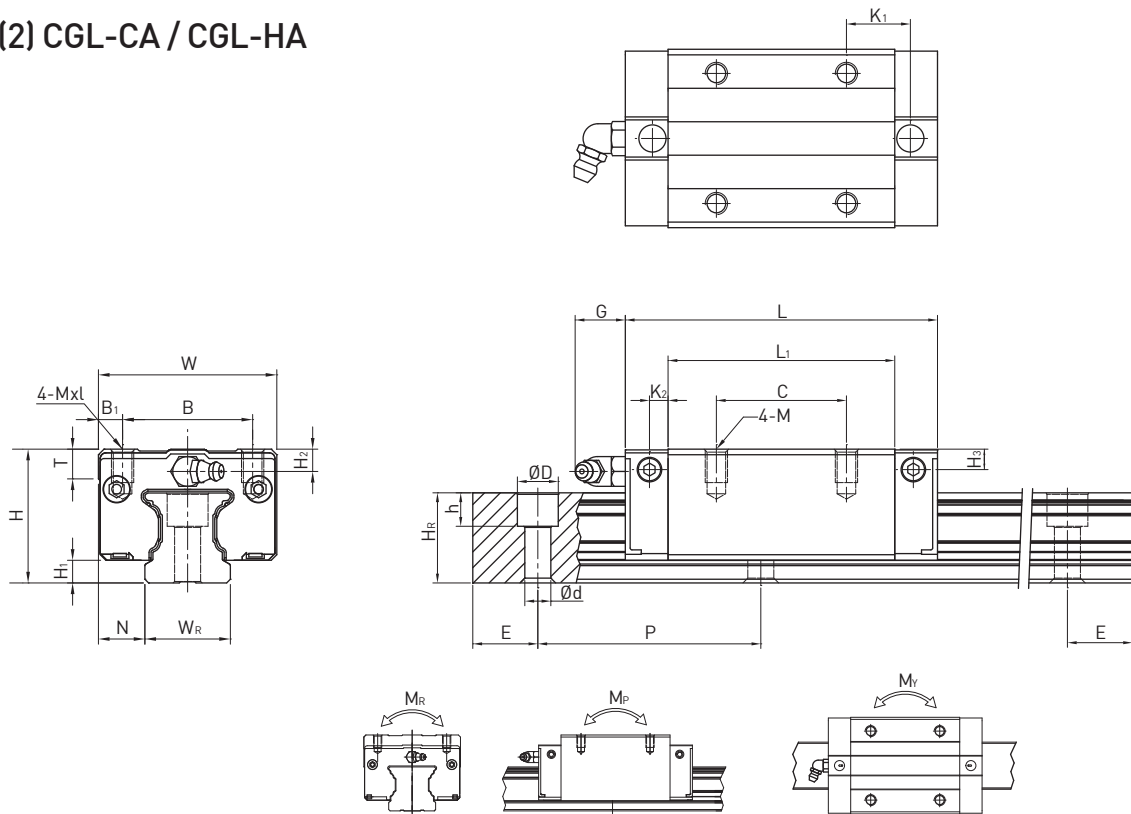

Model No.	Dimensions of Assembly (mm)			Dimensions of Block (mm)											Dimensions of Rail (mm)						Mounting Bolt for Rail (mm)	Basic Dynamic Load Rating C (kN)	Basic Static Load Rating Co (kN)	Static Rated Moment			Weight				
	H	H1	N	W	B	B1	C	L1	L	G	K1	K2	T	H2	H3	Mxl	WR	Hr	D	h				d	P	E	MR	MP	MY	Block kg	Rail kg/m
CGL15CA	24	4.1	9.5	34	26	4	26	39.6	58.2	6	10.8	4.3	6	3.8	3.8	M4x6	15	16.2	7.5	5.9	4.5	60	20	M4x17	14.7	19.52	0.19	0.14	0.14	0.11	1.58
CGL25CA	36	6.1	12.5	48	35	6.5	35	61	84	13	17.4	5	8	6	5.5	M6x8	23	24.25	11	9	7	60	20	M6x22	34.96	43.94	0.6	0.49	0.49	0.37	3.38
CGL25HA	36	6.1	12.5	48	35	6.5	50	78.4	101.4	13	18.6	5	8	6	5.5	M6x8	23	24.25	11	9	7	60	20		40.5	54.08	0.74	0.73	0.73	0.47	3.38
CGL30CA	42	7	16	60	40	10	40	69	97.4	13	19.75	8.7	9.5	6.7	7	M8x10	28	28	14	12	9	80	20	M8x25	46	55.19	0.95	0.7	0.7	0.61	5.1
CGL30HA	42	7	16	60	40	10	60	91.5	119.9	13	21	8.7	9.5	6.7	7	M8x10	28	28	14	12	9	80	20		58.59	78.18	1.35	1.23	1.23	0.82	5.1
CGL35CA	48	7.6	18	70	50	10	50	79	111.4	13	22.6	7	10.2	9	7	M8x13	34	31.85	14	12	9	80	20	M8x28	61.17	79.3	1.73	1.09	1.09	0.93	7.14
CGL35HA	48	7.6	18	70	50	10	72	103.4	135.8	13	23.8	7	10.2	9	7	M8x13	34	31.85	14	12	9	80	20		77.9	112.34	2.46	2.02	2.02	1.22	7.14
CGL45CA	60	9.7	20.5	86	60	13	60	97.2	137.6	13	23	8.7	16	8.5	8.2	M10x17	45	39.85	20	17	14	105	22.5	M12x37	98.43	112.66	3.56	2.35	2.35	1.72	11.51
CGL45HA	60	9.7	20.5	86	60	13	80	133.6	174	13	31.2	8.7	16	8.5	8.2	M10x17	45	39.85	20	17	14	105	22.5		125.58	159.6	5.05	4.45	4.45	2.39	11.51

Note : 1 kgf = 9.81 N