

(5) HGW-CC / HGW-HC

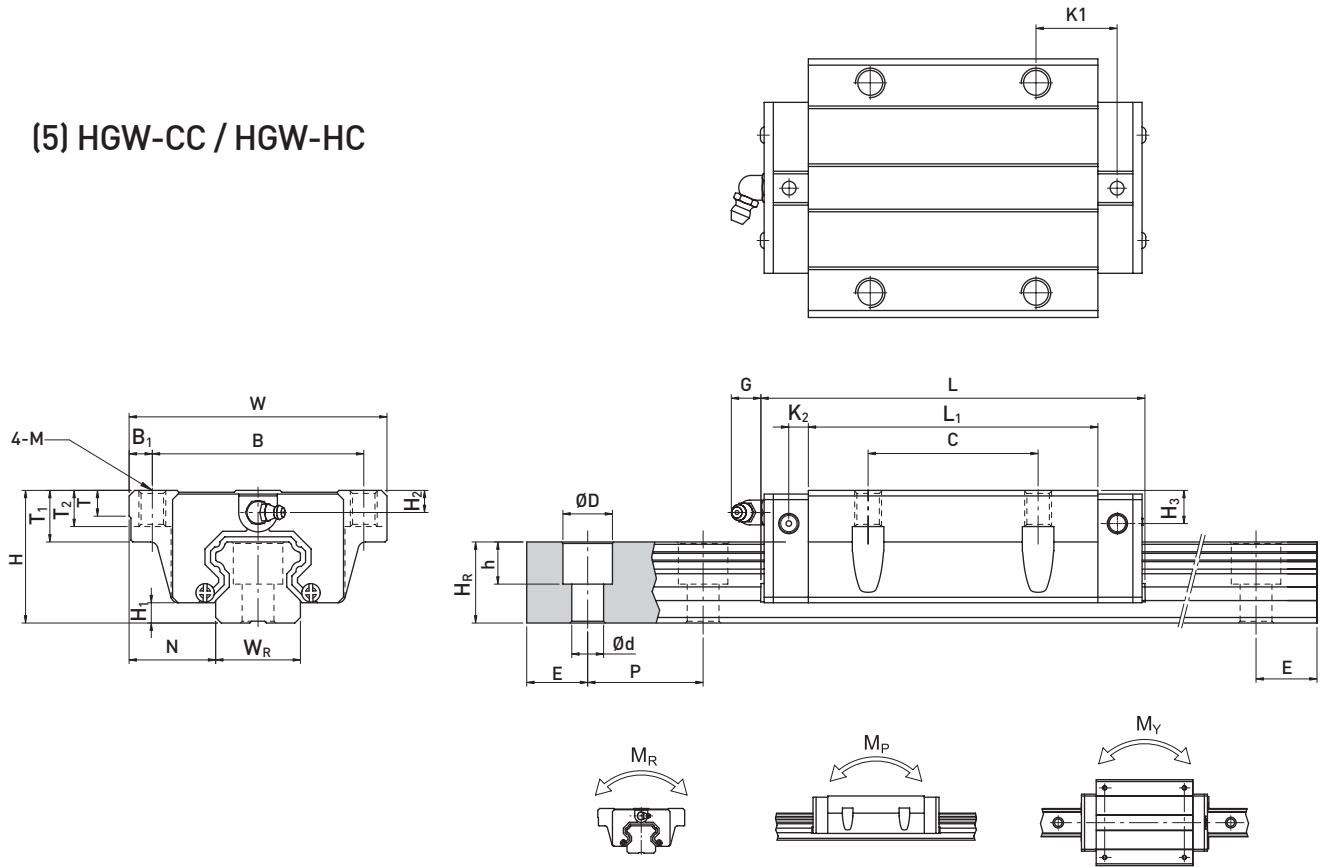

Model No.	Dimensions of Assembly (mm)		Dimensions of Block (mm)															Dimensions of Rail (mm)		Mounting Bolt for Rail (mm)	Basic Dynamic Load Rating C(kN)	Basic Static Load Rating C ₀ (kN)	Static Rated Moment			Weight								
	H	H ₁	N	W	B	B ₁	C	L ₁	L	K ₁	K ₂	G	M	T	T ₁	T ₂	H ₂	H ₃	W _R				H _R	D	h	d	P	E	M _R	M _P	M _Y	Block kg	Rail kg/m	
																															kN-m	kN-m	kN-m	kg
HGW15CC	24	4.3	16	47	38	4.5	30	39.4	61.4	8	4.85	5.3	M5	6	8.9	6.95	3.95	3.7	15	15	7.5	5.3	4.5	60	20	M4x16	14.7	23.47	0.12	0.10	0.10	0.17	1.45	
HGW20CC	30	4.6	21.5	63	53	5	40	50.5	77.5	10.25	6	12	M6	8	10	9.5	6	6	20	17.5	9.5	8.5	6	60	20	M5x16	27.1	36.68	0.27	0.20	0.20	0.40	2.21	
HGW20HC								65.2	92.2	17.6																	32.7	47.96	0.35	0.35	0.35	0.52		
HGW25CC	36	5.5	23.5	70	57	6.5	45	58	84	10.7	6	12	M8	8	14	10	6	5	23	22	11	9	7	60	20	M6x20	34.9	52.82	0.42	0.33	0.33	0.59	3.21	
HGW25HC								78.6	104.6	21																	42.2	69.07	0.56	0.57	0.57	0.80		
HGW30CC	42	6	31	90	72	9	52	70	97.4	14.25	6	12	M10	8.5	16	10	6.5	10.8	28	26	14	12	9	80	20	M8x25	48.5	71.87	0.66	0.53	0.53	1.09	4.47	
HGW30HC								93	120.4	25.75																	58.6	93.99	0.88	0.92	0.92	1.44		
HGW35CC	48	7.5	33	100	82	9	62	80	112.4	14.6	7	12	M10	10.1	18	13	9	12.6	34	29	14	12	9	80	20	M8x25	64.6	93.88	1.16	0.81	0.81	1.56	6.30	
HGW35HC								105.8	138.2	27.5																	77.9	122.77	1.54	1.40	1.40	2.06		
HGW45CC	60	9.5	37.5	120	100	10	80	97	139.4	13	10	12.9	M12	15.1	22	15	8.5	20.5	45	38	20	17	14	105	22.5	M12x35	103.8	146.71	1.98	1.55	1.55	2.79	10.41	
HGW45HC								128.8	171.2	28.9																	125.3	191.85	2.63	2.68	2.68	3.69		
HGW55CC	70	13	43.5	140	116	12	95	117.7	166.7	17.35	11	12.9	M14	17.5	26.5	17	12	19	53	44	23	20	16	120	30	M14x45	153.2	211.23	3.69	2.64	2.64	4.52	15.08	
HGW55HC								155.8	204.8	36.4																	184.9	276.23	4.88	4.57	4.57	5.96		
HGW65CC	90	15	53.5	170	142	14	110	144.2	200.2	23.1	14	12.9	M16	25	37.5	23	15	15	63	53	26	22	18	150	35	M16x50	213.2	287.48	6.65	4.27	4.27	9.17	21.18	
HGW65HC								203.6	259.6	52.8																	277.8	420.17	9.38	7.38	7.38	12.89		

Note : 1 kgf = 9.81 N