

# HG Series

## Heavy Load Ball Type

Oil refilling rate

Table 2-1-16

Size	Refilling rate (cm <sup>3</sup> /hr)	Size	Refilling rate (cm <sup>3</sup> /hr)
HG15	0.2	HG35	0.3
HG20	0.2	HG45	0.4
HG25	0.3	HG55	0.5
HG30	0.3	HG65	0.6

### 2-1-8 Dust Proof Accessories

#### (1) Codes of standard dust proof accessories

If the following accessories are needed, please add the code followed by the model number.

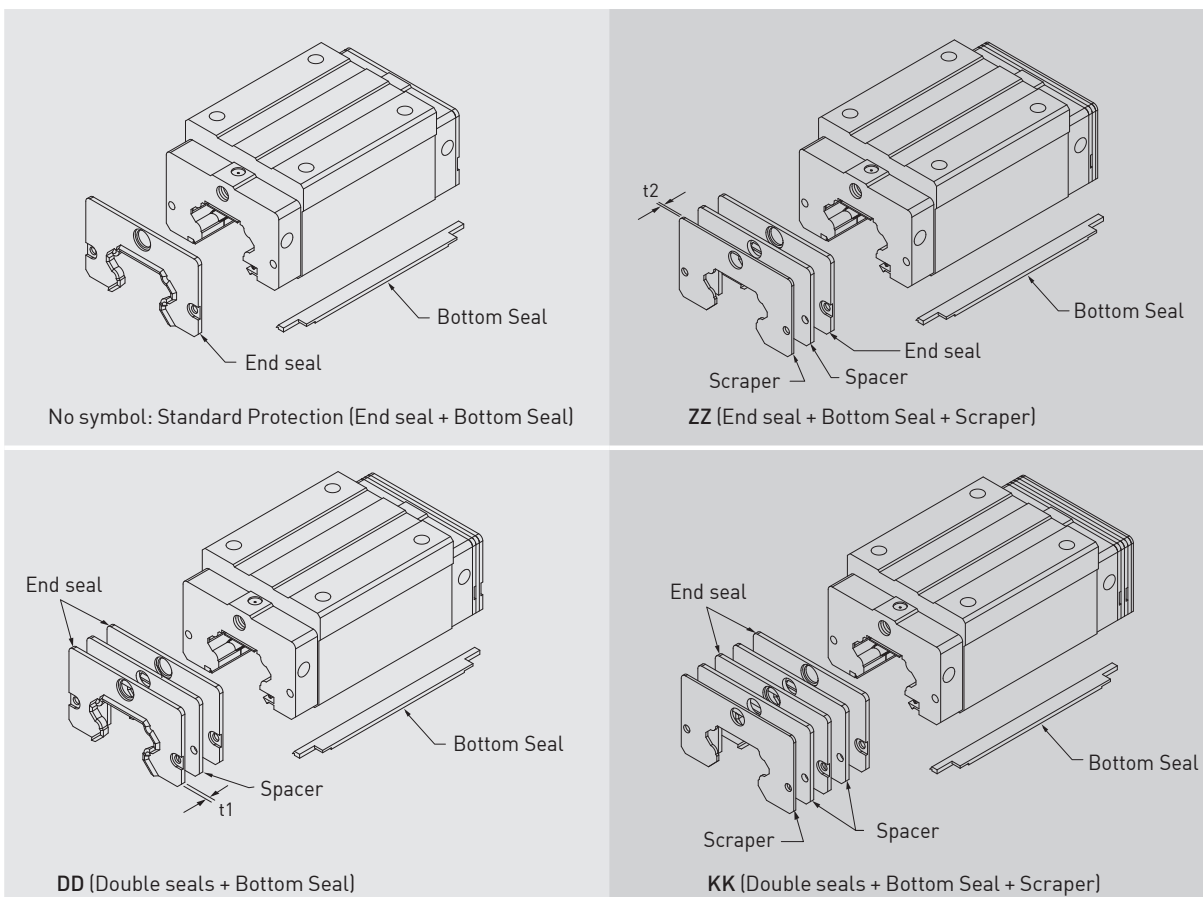

Note: HG20/25/65 are without spacer.

**(2) Codes of high-dust proof accessories**

HIWIN develops many kinds of dust proof accessories for different application and working environment to avoid dust or debris. If the following accessories are needed, please add the code followed by the model number.

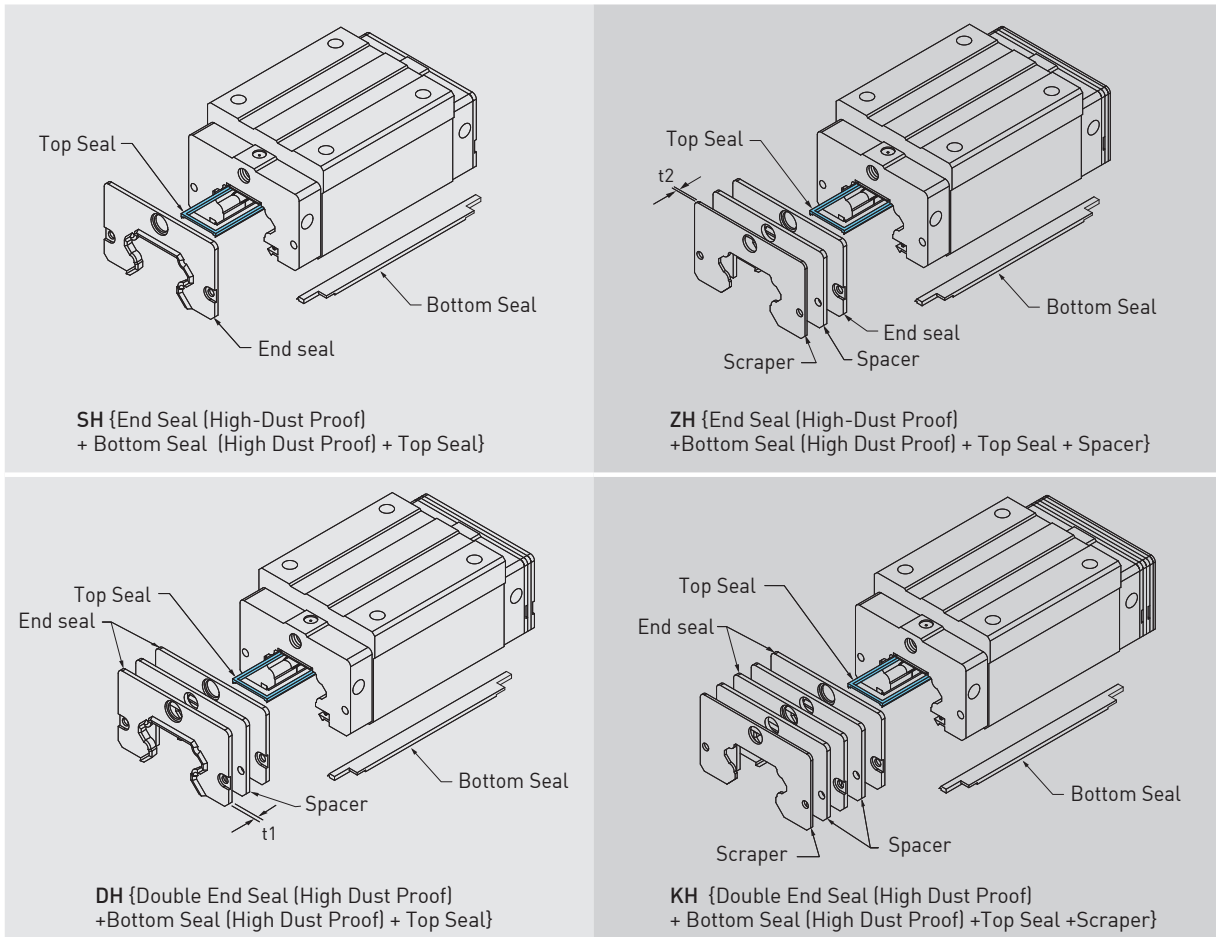

- Note: 1. The available size for high dust proof accessories are HG20(C/H), 25(C/H), 30(C/H), 35(C/H) and 45C.  
2. The value of friction force will increase 0.6~1.2 kgf.  
3. HG20/25 are without spacer.

## HG Series

### Heavy Load Ball Type

#### (3) Codes of ultra-high dust proof accessories

Hiwin has developed high dust proof accessories which is used for environment that is full of dust and particle, such as wood working machinery and glass/stone machining equipment. These accessories show high performance of dust proof. If accessories are needed, please add the code followed by the model number.

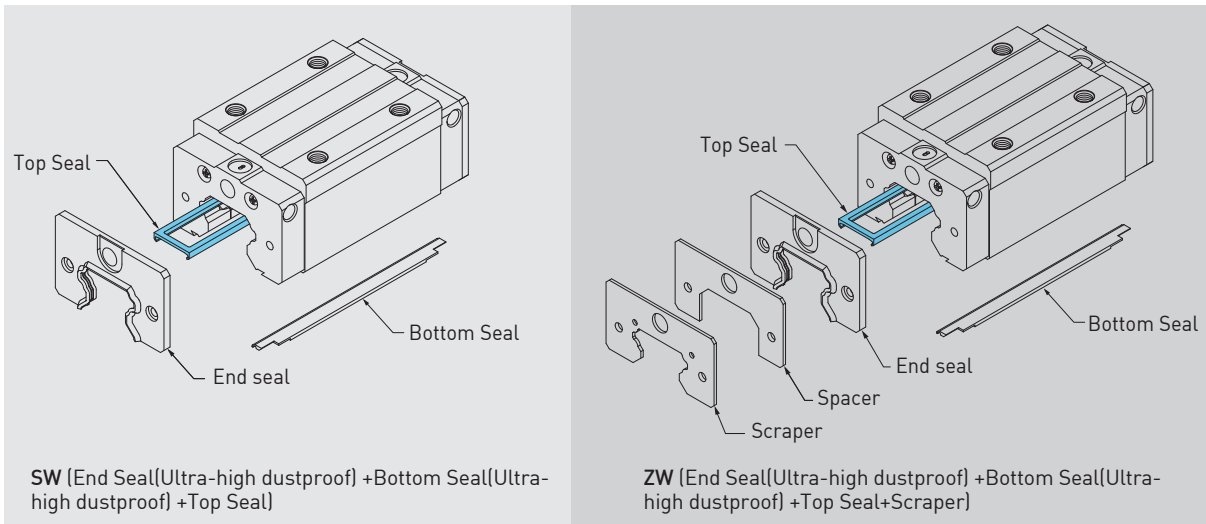

Note : 1. The available size for high dust proof accessories are HG15C, HG20(C/H), HG30(C/H), HG35(C/H), HG45(C/H).  
2. The value of friction force will increase 1.5~4.0 kgf.

#### (4) Function of dust proof accessories

##### End seal and bottom seal

To prevent life reduction caused by iron chips or dust entering the block.

##### Double seals

Enhances the wiping effect, foreign matter can be completely wiped off.

Table 2-1-17 Dimensions of end seal

Size	Thickness (t1) (mm)	Size	Thickness (t1) (mm)
HG15 ES	3	HG35 ES	3.2
HG20 ES	3.5	HG45 ES	4.5
HG25 ES	3.5	HG55 ES	4.5
HG30 ES	3.2	HG65 ES	6

##### Scraper

The scraper removes high-temperature iron chips and larger foreign objects.

Table 2-1-18 Dimensions of scraper

Size	Thickness (t2) (mm)	Size	Thickness (t2) (mm)
HG15 SC	1.5	HG35 SC	1.5
HG20 SC	1.5	HG45 SC	1.5
HG25 SC	1.5	HG55 SC	1.5
HG30 SC	1.5	HG65 SC	1.5

##### Top Seal

Top seal can efficiently avoid dust from the surface of rail or tapping hole getting inside the block.