

QH Series

Heavy Load Type

2-5-11 Dimensions for HIWIN QH Series

(1) QHH-CA / QHH-HA

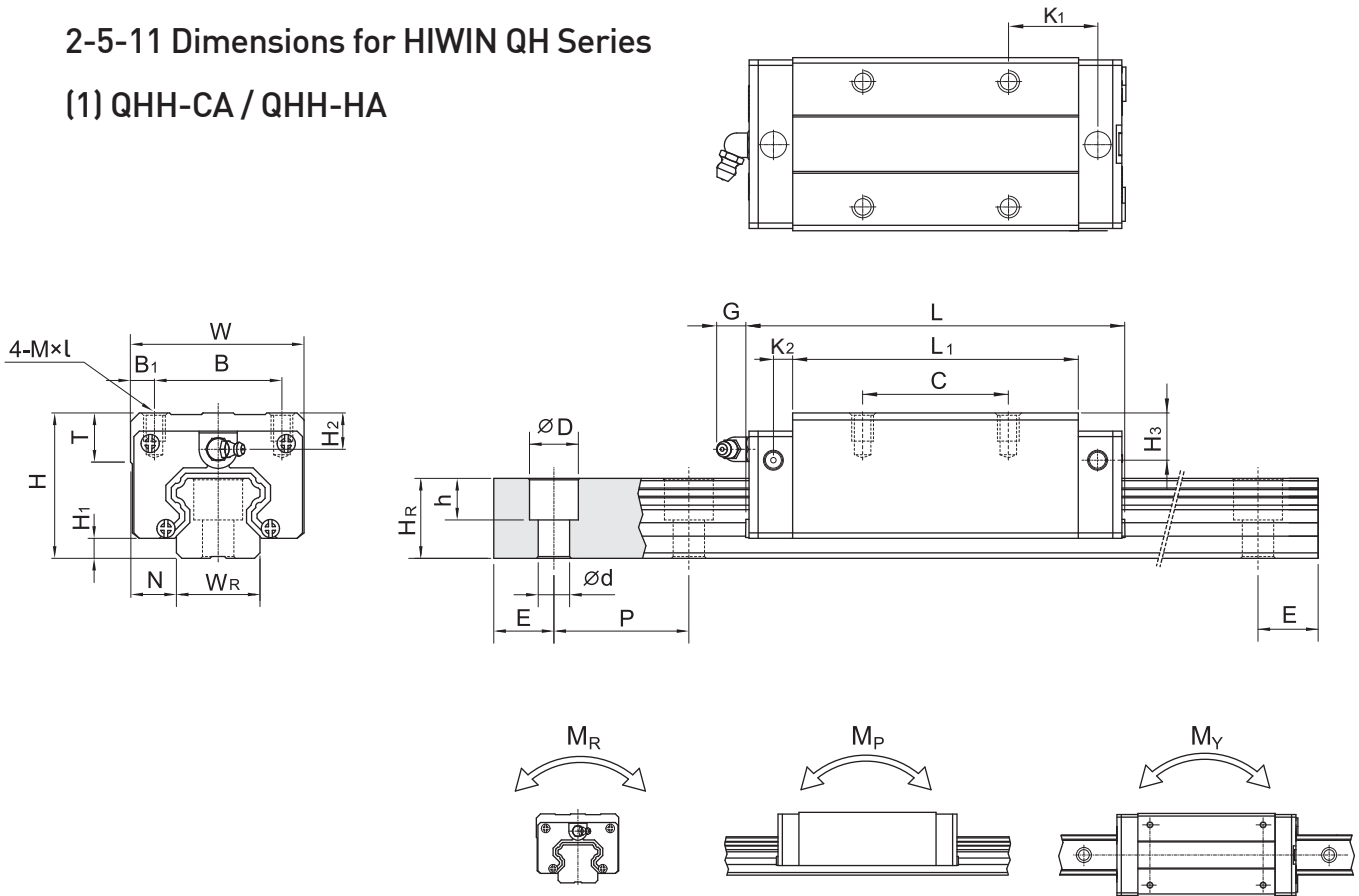

Model No.	Dimensions of Assembly (mm)			Dimensions of Block (mm)											Dimensions of Rail (mm)					Mounting Bolt for Rail (mm)	Basic Dynamic Load Rating C (kN)	Basic Static Load Rating C ₀ (kN)	Static Rated Moment			Weight					
	H	H ₁	N	W	B	B ₁	C	L ₁	L	K ₁	K ₂	G	MxL	T	H ₂	H ₃	W _R	H _R	D				h	d	P	E	M _R	M _P	M _Y	Block	Rail
	mm	mm	mm	mm	mm	mm	mm	mm	mm	mm	mm	mm	mm	mm	mm	mm	mm	mm	mm				mm	mm	mm	mm	kN-m	kN-m	kN-m	kg	kg/m
QHH15CA	28	4	9.5	34	26	4	26	39.4	61.4	10	5	5.3	M4 x 5	6	7.95	8.2	15	15	7.5	5.3	4.5	60	20	M4x16	17.94	19.86	0.10	0.08	0.08	0.18	1.45
QHH20CA	30	4.6	12	44	32	6	36	50.5	76.7	11.75	6	12	M5 x 6	8	6	6	20	17.5	9.5	8.5	6	60	20	M5x16	30.0	33.86	0.26	0.19	0.19	0.29	2.21
QHH20HA							50	65.2	91.4	12.1															35.7	42.31	0.31	0.27	0.27	0.38	
QHH25CA	40	5.5	12.5	48	35	6.5	35	58	83.4	15.7	6	12	M6 x 8	8	10	9	23	22	11	9	7	60	20	M6x20	41.9	48.75	0.39	0.31	0.31	0.50	3.21
QHH25HA							50	78.6	104	18.5															50.61	60.94	0.50	0.45	0.45	0.68	
QHH30CA	45	6	16	60	40	10	40	70	97.4	19.5	6.25	12	M8x10	8.5	9.5	9	28	26	14	12	9	80	20	M8x25	58.26	66.34	0.60	0.5	0.50	0.87	4.47
QHH30HA							60	93	120.4	21.75															70.32	88.45	0.83	0.89	0.89	1.15	
QHH35CA	55	7.5	18	70	50	10	50	80	113.6	19	7.5	12	M8x12	10.2	15.5	13.5	34	29	14	12	9	80	20	M8x25	78.89	86.66	1.07	0.76	0.76	1.44	6.30
QHH35HA							72	105.8	139.4	20.9															95.23	115.55	1.45	1.33	1.33	1.90	
QHH45CA	70	9.2	20.5	86	60	13	60	97	139.4	23	10	12.9	M10x17	16	18.5	20	45	38	20	17	14	105	22.5	M12x35	119.4	135.42	1.83	1.38	1.38	2.72	10.41
QHH45HA							80	128.8	171.2	29.09															144.13	180.56	2.47	2.41	2.41	3.59	

Note : 1 kgf = 9.81 N