

(4) QHW-CC / QHW-HC

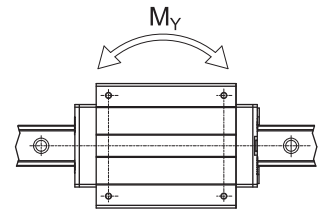
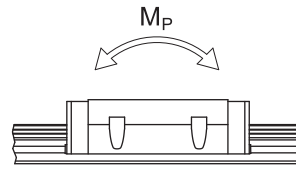
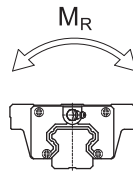
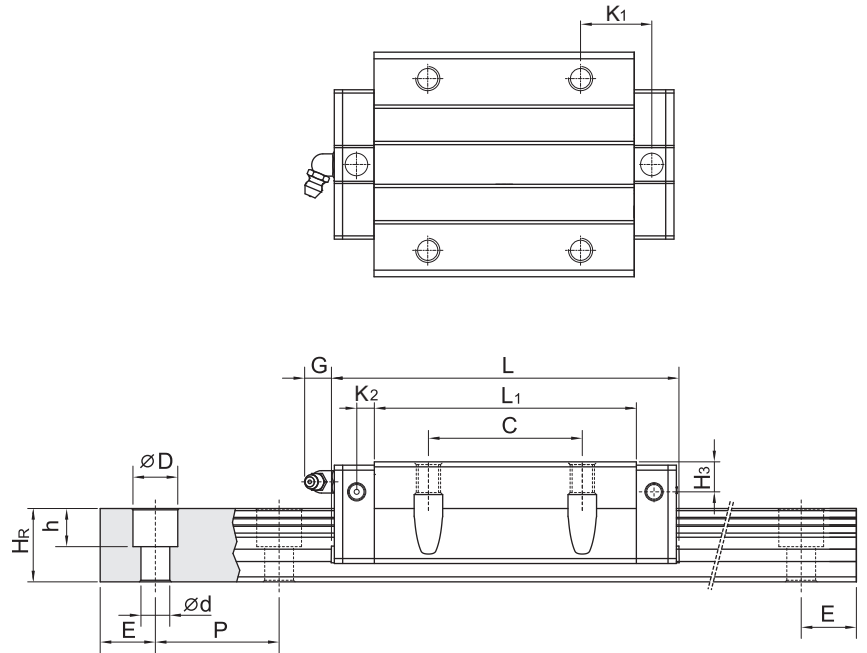
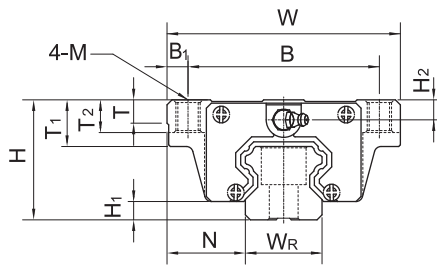

Model No.	Dimensions of Assembly (mm)			Dimensions of Block (mm)													Dimensions of Rail (mm)										Mounting Bolt for Rail (mm)	Basic Dynamic Load Rating C (kN)	Basic Static Load Rating C ₀ (kN)	Static Rated Moment			Weight	
	H	H ₁	N	W	B	B ₁	C	L ₁	L	K ₁	K ₂	G	M	T	T ₁	T ₂	H ₂	H ₃	W _R	H _R	D	h	d	P	E	M _R				M _p	M _Y	Block	Rail	
	kg	mm	mm	mm	mm	mm	mm	mm	mm	mm	mm	mm	mm	mm	mm	mm	mm	mm	mm	mm	mm	mm	mm	mm	mm	mm				kN-m	kN-m	kN-m	kg	kg/m
QHW15CC	24	4	16	47	38	4.5	30	39.4	61.4	8	5	5.3	M5	6	8.9	6.95	3.95	4.2	15	15	7.5	5.3	4.5	60	20	M4x16	17.94	19.86	0.1	0.08	0.08	0.17	1.45	
QHW20CC	30	4.6	21.5	63	53	5	40	50.5	76.7	9.75	6	12	M6	8	10	9.5	6	6	20	17.5	9.5	8.5	6	60	20	M5x16	30.0	33.86	0.26	0.19	0.19	0.40	2.21	
QHW20HC								65.2	91.4	17.1																	35.7	42.31	0.31	0.27	0.27	0.52		
QHW25CC	36	5.5	23.5	70	57	6.5	45	58	83.4	10.7	6	12	M8	8	14	10	6	5	23	22	11	9	7	60	20	M6x20	41.9	48.75	0.39	0.31	0.31	0.59	3.21	
QHW25HC								78.6	104	21																	50.61	60.94	0.5	0.45	0.45	0.80		
QHW30CC	42	6	31	90	72	9	52	70	97.4	13.5	6.25	12	M10	8.5	16	10	6.5	6	28	26	14	12	9	80	20	M8x25	58.26	66.34	0.6	0.5	0.5	1.09	4.47	
QHW30HC								93	120.4	25.75																	70.32	88.45	0.83	0.89	0.89	1.44		
QHW35CC	48	7.5	33	100	82	9	62	80	113.6	13	7.5	12	M10	10.1	18	13	8.5	6.5	34	29	14	12	9	80	20	M8x25	78.89	86.66	1.07	0.76	0.76	1.56	6.30	
QHW35HC								105.8	139.4	25.9																	95.23	115.55	1.45	1.33	1.33	2.06		
QHW45CC	60	9.2	37.5	120	100	10	80	97	139.4	13	10	12.9	M12	15.1	22	15	8.5	10	45	38	20	17	14	105	22.5	M12x35	119.4	135.42	1.83	1.38	1.38	2.79	10.41	
QHW45HC								128.8	171.2	28.9																	144.13	180.56	2.47	2.41	2.41	3.69		

Note : 1 kgf = 9.81 N