

○ Oil feeding rate

Table 2-2-12 oil feed rate

Size	feed rate (cm <sup>3</sup> /hr)	Size	feed rate (cm <sup>3</sup> /hr)
EG15	0.1	EG30	0.2
EG20	0.133	EG35	0.233
EG25	0.167		

## 2-2-8 Dust Protection Equipment

### (1) Codes of equipment

If the following equipment is needed, please indicate the code followed by the model number.

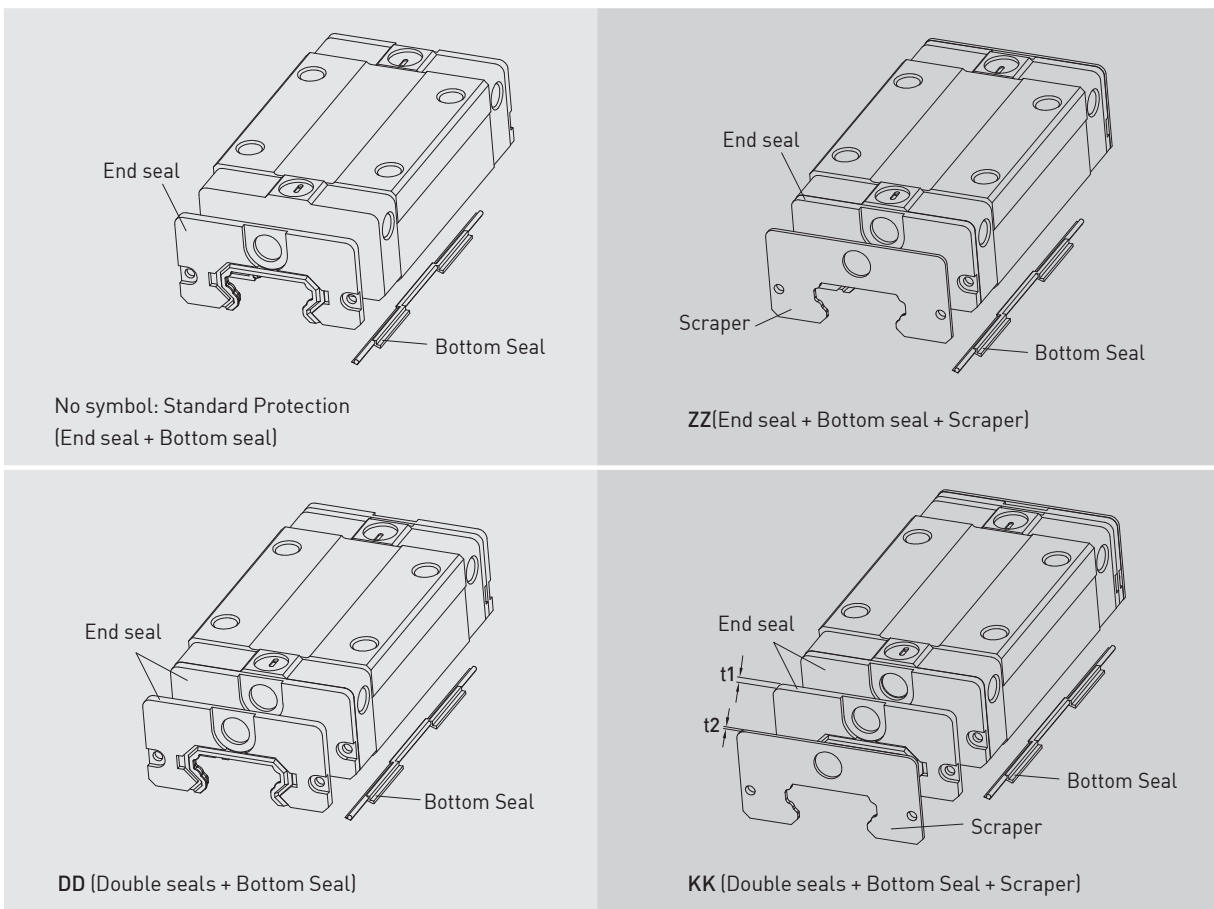

### (2) End seal and bottom seal

Protects against contaminants entering the block. Reduces potential for groove damage resulting in a reduction of life ratings.

### (3) Double seals

Removing foreign matters from the rail to prevent contaminants from entering the block.

Table 2-2-13 Dimensions of end seal

Size	Thickness (t1) (mm)	Size	Thickness (t1) (mm)
EG15 ES	2	EG30 ES	2
EG20 ES	2	EG35 ES	2
EG25 ES	2		