

QH Series

Heavy Load Type

2-5-7 Dust Proof Accessories

(1) Codes of accessories

If the following accessories are needed, please add the code followed by the model number.

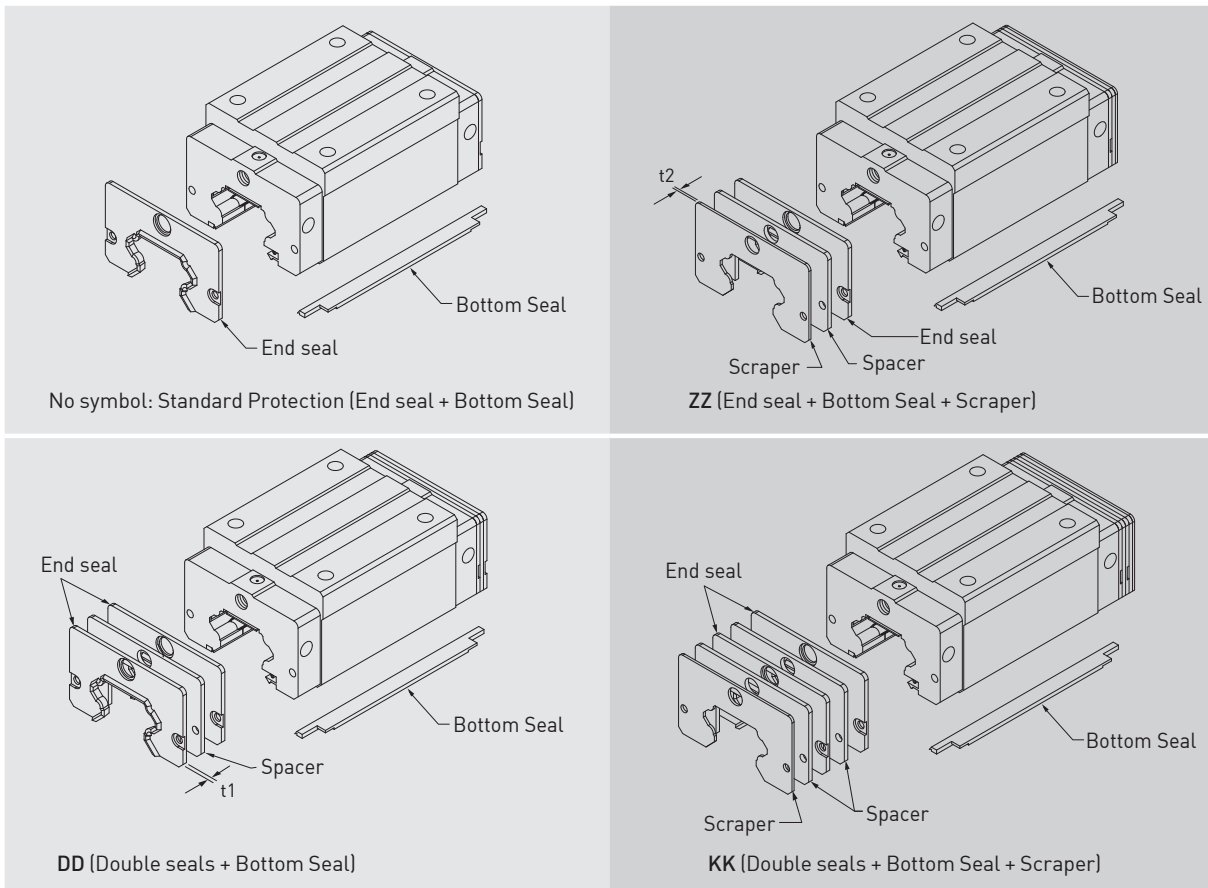

(2) End seal and bottom seal

To prevent life reduction caused by iron chips or dust entering the block.

(3) Double seals

Enhances the wiping effect, foreign matter can be completely wiped off.

Table 2-5-13 Dimensions of end seal

Size	Thickness (t1) (mm)	Size	Thickness (t1) (mm)
QH15 ES	3	QH30 ES	3.2
QH20 ES	2.5	QH35 ES	2.5
QH25 ES	2.5	QH45 ES	3.6

(4) Scraper

The scraper removes high-temperature iron chips and larger foreign objects.

Table 2-5-14 Dimensions of scraper

Size	Thickness (t2) (mm)	Size	Thickness (t2) (mm)
QH15 SC	1.5	QH30 SC	1.5
QH20 SC	1.5	QH35 SC	1.5
QH25 SC	1.5	QH45 SC	1.5

(5) Dimensions of block equipped with the dustproof parts

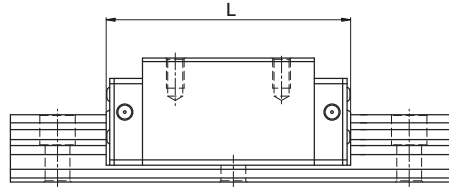

Table 2-5-15 Overall block length

unit: mm

Size	Overall block length (L)			
	SS	ZZ	DD	KK
QH15C	61.4 (61.8)	68.4 (69.4)	68.0 (68.4)	75.0 (76.0)
QH20C	76.7 (78.9)	81.9 (84.5)	81.7 (83.9)	86.9 (89.5)
QH20H	91.4 (93.6)	96.6 (99.2)	96.4 (98.6)	101.6 (104.2)
QH25C	83.4 (86.0)	89.4 (92.0)	88.4 (91.0)	94.4 (97.0)
QH25H	104.0 (106.6)	110.0 (112.6)	109.0 (111.6)	115.0 (117.6)
QH30C	97.4 (99.4)	104.8 (107.4)	104.8 (106.8)	112.2 (114.8)
QH30H	120.4 (122.4)	127.8 (130.4)	127.8 (129.8)	135.2 (137.8)
QH35C	113.6 (114.4)	119.0 (120.0)	118.6 (119.4)	124.0 (125.0)
QH35H	139.4 (140.2)	144.8 (145.8)	144.4 (145.2)	149.8 (150.8)
QH45C	139.4 (139.4)	147.2 (147.2)	146.6 (146.6)	154.4 (154.4)
QH45H	171.2 (171.2)	179.0 (179.0)	178.4 (178.4)	186.2 (186.2)

Note : The marking of "()" denotes the maximum block length with screws, lips of end seals, etc.