

Linear Bearing

Technical Information





Multi-Axis Robot

- Pick-and-Place / Assembly / Array and Packaging / Semiconductor / Electro-Optical Industry / Automotive Industry / Food Industry
- Articulated Robot
 - Delta Robot
 - SCARA Robot
 - Wafer Robot
 - Electric Gripper
 - Integrated Electric Gripper
 - Rotary Joint



Single-Axis Robot

- Precision / Semiconductor / Medical / FPD
- KK, SK
 - KS, KA
 - KU, KE, KC



Torque Motor Rotary Table

- Aerospace / Medical / Automotive Industry / Machine Tools / Machinery Industry
- RAB Series
 - RAS Series
 - RCV Series
 - RCH Series



Ballscrew

- Precision Ground / Rolled
- Super S Series
 - Super T Series
 - Mini Roller
 - Ecological & Economical Lubrication Module E2
 - Rotating Nut (R1)
 - Energy-Saving & Thermal-Controlling (Cool Type)
 - Heavy Load Series (RD)
 - Ball Spline



Linear Guideway

- Automation / Semiconductor / Medical
- Ball Type--HG, EG, WE, MG, CG
 - Quiet Type--QH, QE, QW, QR
 - Other--RG, E2, PG, SE, RC



Bearing

- Machine Tools / Robot
- Crossed Roller Bearing
 - Ballscrew Bearing
 - Linear Bearing
 - Support Unit



DATORKER® Robot Reducer

- Robot / Automation Equipment / Semiconductor Equipment / Machine Tools
- WUT-PO Type
 - WUI-CO Type
 - WTI-PH Type
 - WTI-AH Type



AC Servo Motor & Drive

- Semiconductor / Packaging Machine / SMT / Food Industry / LCD
- Drives--D1, D1-N, D2T/D2T-LM
 - Motors--50W-2000W

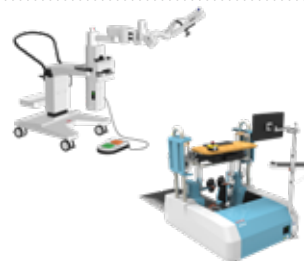

Medical Equipment

- Hospital / Rehabilitation Centers / Nursing Homes
- Robotic Gait Training System
 - Robotic Endoscope Holder



Linear Motor

- Automated Transport / AOI Application / Precision / Semiconductor
- Iron-core Linear Motor
 - Coreless Linear Motor
 - Linear Turbo Motor LMT
 - Planar Servo Motor
 - Air Bearing Platform
 - X-Y Stage
 - Gantry Systems



Torque Motor & Direct Drive Motor

- Machine Tools
- Torque Motor--TMRW Series
- Inspection / Testing Equipment / Robot
- Direct Drive Motor--DMS, DMY, DMN Series

HIWIN®

Linear Bearing

1. HIWIN Linear Bearing General Information

1-1 Characteristics	1
1-2 Description	1
1-3 Fitting	2

2. Configuration and Specifications

2-1 Metric Dimensions

2-1-1 UB Series: Standard Closed Type, Clearance Adjustable Type, Open Type	4
2-1-2 UBM Series: Standard Closed Type, Clearance Adjustable Type, Open Type ...	5

2-2 Metric Dimensions - Japanese Exclusive

2-2-1 JB Series: Standard Closed Type, Clearance Adjustable Type, Open Type	6
2-2-2 JBM Series: Standard Closed Type, Clearance Adjustable Type, Open Type ...	7
2-2-3 Japanese Lengthened Type : JBL	8
2-2-4 Japanese Flanged Type : JBF&JBK	9
2-2-5 Japanese Flanged & Lengthened Type : JBFL&JBKF	10

* The specifications in this catalogue are subject to change without notification.

1

HIWIN Linear Bearing General Information

1-1 Characteristics of HIWIN Linear Bearing

- **HIWIN linear bearings** enable high precision linear motion on round shafts by utilizing recirculating ball pathways.
- The recirculation curve enables HIWIN's linear bearing to sustain heavy loads with low noise and high stiffness.
- HIWIN's diverse line of linear bearings perform under almost any conditions and load capacities to satisfy a wide range of applications.

1-2 Description

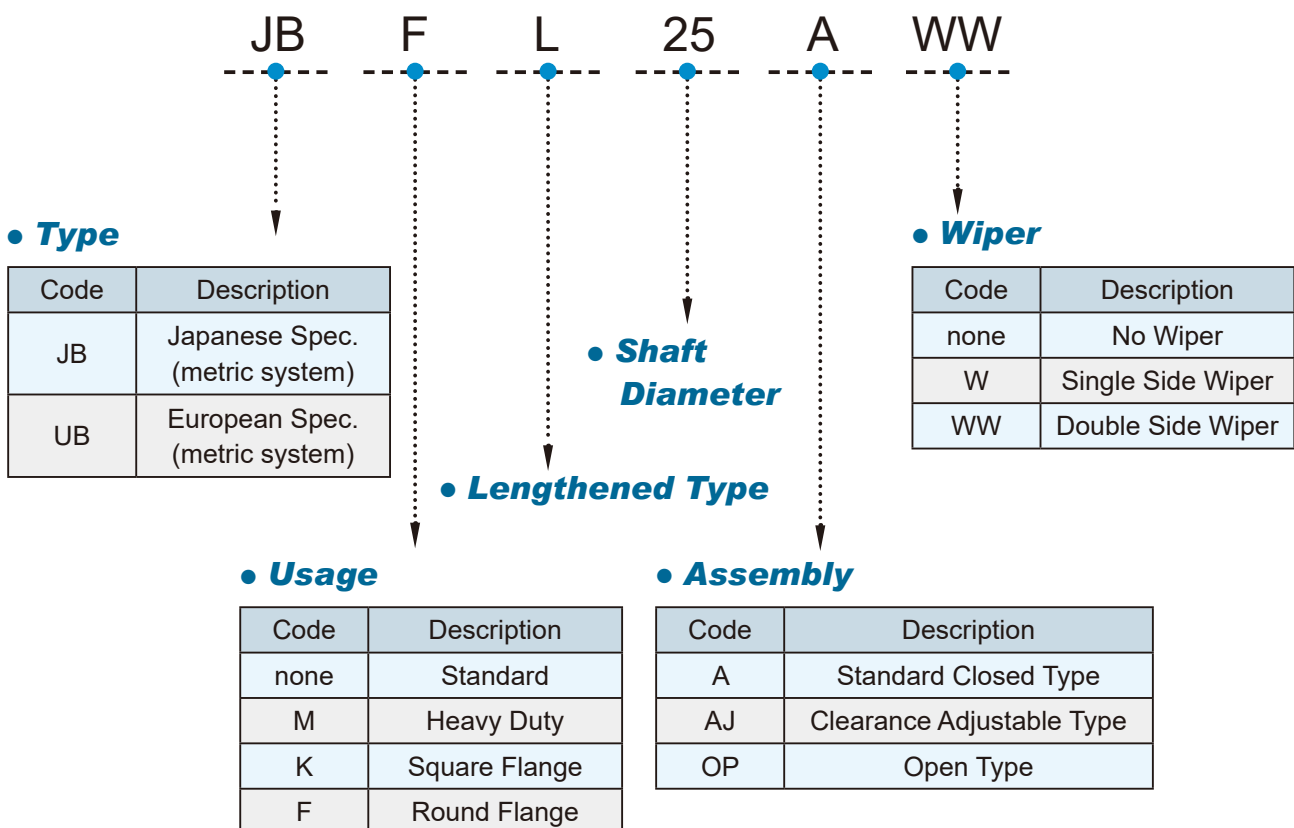

1-3 Fitting

● Table 1. Recommended fitting tolerance

Type		Shaft		(Housing)	
Model	Accuracy	Normal clearance	Close clearance	Loose fit	Transition fit
JB	General grade	g6	h6	H7	J7
	Precision grade	g5	h5	H6	J6
UB	General grade	g6	j6	H7	J7

Note: In general fitting condition shaft is clearance fit

● **Installation:**

1. Standard Closed Type Installation:

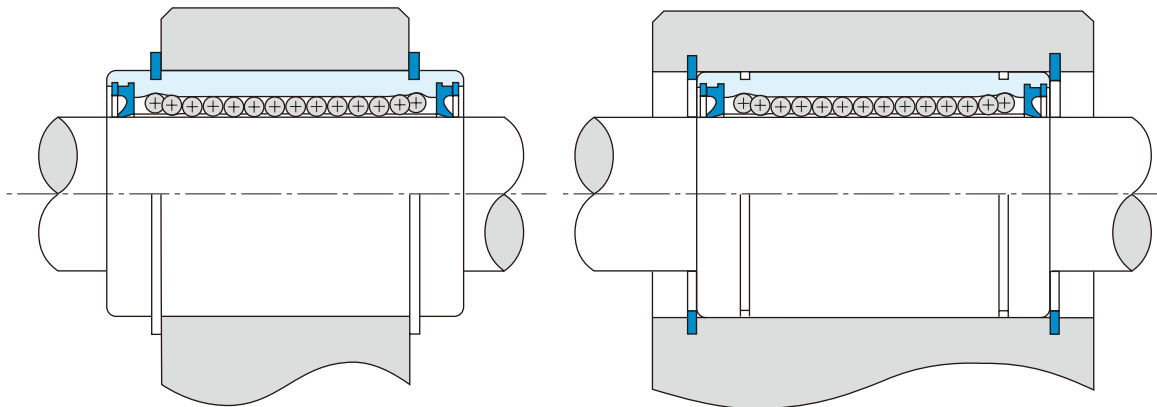

Fig. 1 Installation with snap-rings.

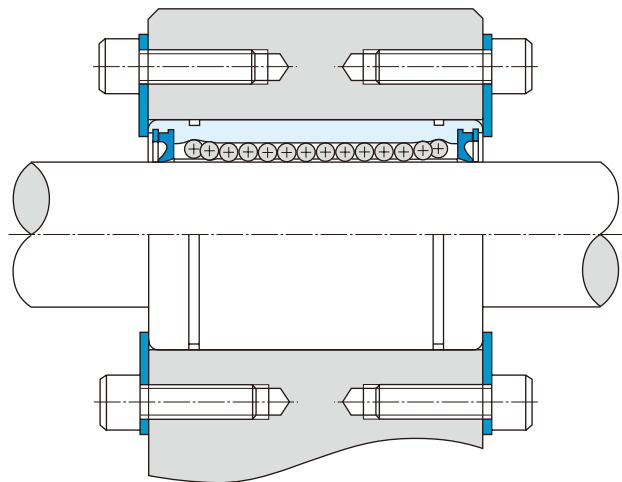

Fig. 2 Installation with setting plate.

2. Installation of the Clearance Adjustment Type

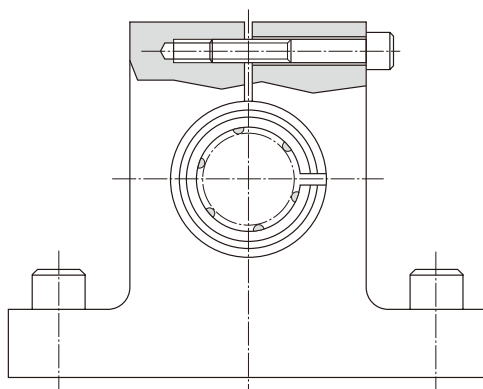

Fig. 3

3. Installation of the Open Type

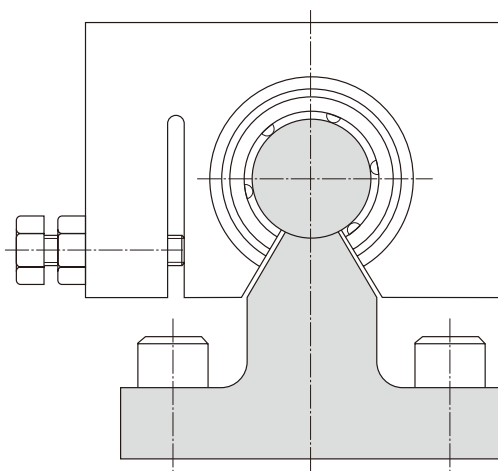

Fig. 4

4. Installation of the Flanged Type

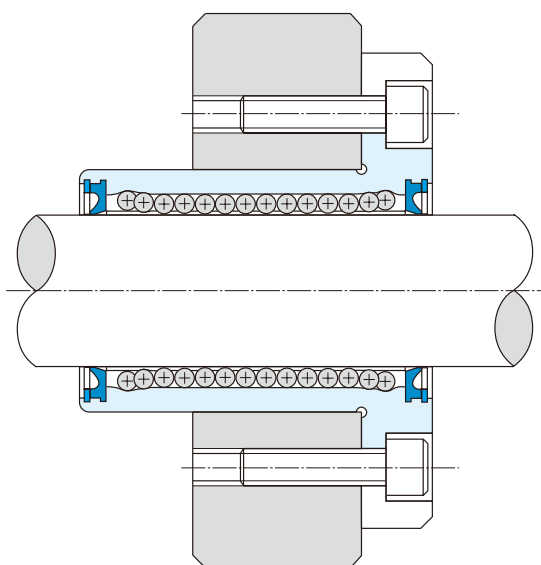
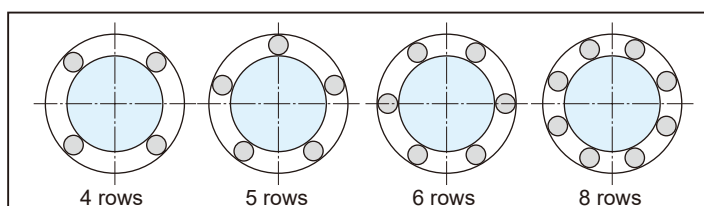

Fig. 5

Note: To achieve optimal life performance it is recommended that installation follow the diagram below according to the corresponding number of ball rows and load directions.



2

Configuration and Specifications

2-1 Metric Dimension

2-1-1 UB Series: Metric Dimension Series Used Most Frequently in Europe

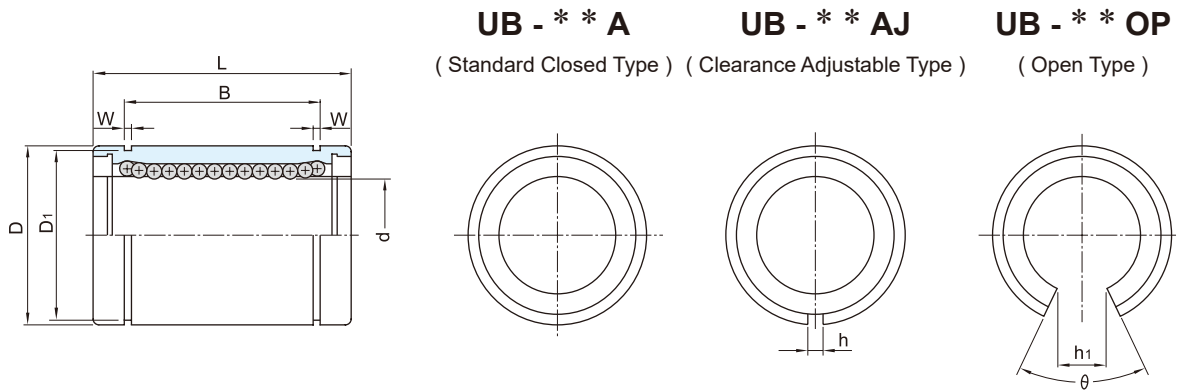

Shaft Diameter d mm	Model						Major Dimensions and Tolerance										Load Capacity				
	Standard Closed Type	Ball Circuit	Clearance Adjustable Type	Ball Circuit	Open Type	Ball Circuit	d mm	Tolerance μ m	D mm	Tolerance μ m	L mm	Tolerance μ m	B mm	Tolerance μ m	W mm	D1 mm	h mm	h1 mm	θ	Basic Dynamic Load Rating C(N)	Basic Static Load Rating Co(N)
8	UB-08A	4	UB-08AJ	4	-	-	8	+8 0	16	0 -8	25	0 -200	16.5	0 -200	1.1	15.2	1	-	-	280	420
12	UB-12A	5	UB-12AJ	5	UB-12OP	4	12	0 -9	22	32	22.9		1.3		21	1.5	7	54°	640	950	
16	UB-16A	5	UB-16AJ	5	UB-16OP	4	16	+9 -1	26	36	24.9	0 -300	0 -300	1.3	24.9	1.5	9.6	60°	720	1120	
20	UB-20A	5	UB-20AJ	5	UB-20OP	4	20	0 -11	32	45	31.5			1.6	30.3	2	11.7	60°	920	1480	
25	UB-25A	6	UB-25AJ	6	UB-25OP	5	25	+11 -1	40	58	44.1	0 -300	0 -300	1.85	37.5	2	12.5	60°	1070	1670	
30	UB-30A	6	UB-30AJ	6	UB-30OP	5	30	0 -13	47	68	52.1			1.85	44.5	2	16.9	60°	1630	2850	
40	UB-40A	6	UB-40AJ	6	UB-40OP	5	40	+13 -2	62	80	60.6	0 -300	0 -300	2.15	59	3	22	60°	2250	4200	
50	UB-50A	6	UB-50AJ	6	UB-50OP	5	50	0 -13	75	100	77.6			2.65	72	3	21	50°	3950	8200	

- Note:** 1. Both Linear bearing with single side wiper (UB.....W) and with double side wiper (UB.....WW) are available.
 2. 1 Kgf=9.81 N=2.2046 Lbf
 3. The tolerances stated above are valid for the "Standard Closed Type".

2-1-2 UBM Series: Metric Dimension Series Used Most Frequently in Europe

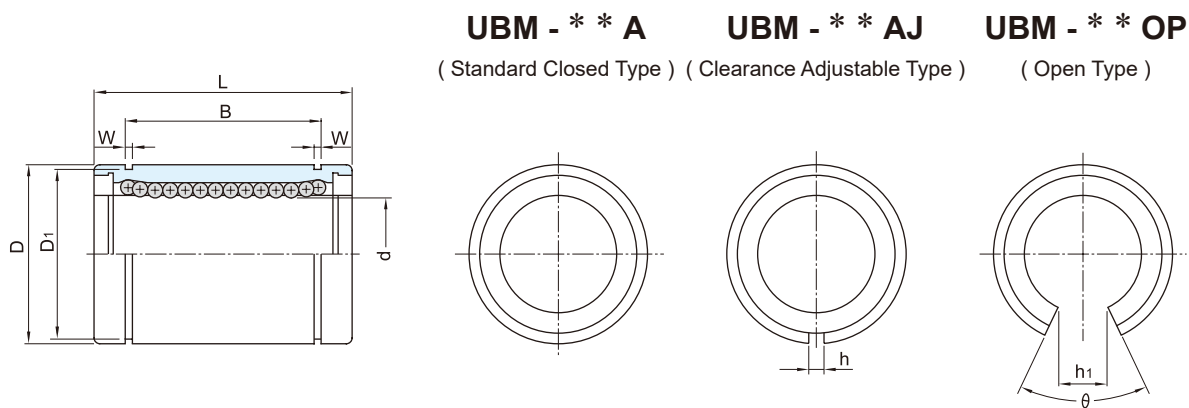

Shaft Diameter d mm	Model						Major Dimensions and Tolerance											Load Capacity			
	Standard Closed Type	Ball Circuit	Clearance Adjustable Type	Ball Circuit	Open Type	Ball Circuit	d		D		L		B		W mm	D1 mm	h mm	h1 mm	θ	Basic Dynamic Load Rating C(N)	Basic Static Load Rating Co(N)
							mm	Tolerance μ m	mm	Tolerance μ m	mm	Tolerance μ m	mm	Tolerance μ m							
12	UBM-12A	6	UBM-12AJ	6	UBM-12OP	4	12	+8 0	22	0	32	0	22.9	0	1.3	21	1.5	10	90°	660	1310
16	UBM-16A	6	UBM-16AJ	6	UBM-16OP	4	16	+9 -1	26	-9	36	0 -200	24.9	0 -200	1.3	24.9	1.5	13.5	100°	800	1480
20	UBM-20A	6	UBM-20AJ	6	UBM-20OP	4	20	+9 -1	32	0	45	0	31.5	0	1.6	30.3	2	16.8	100°	1050	2280
25	UBM-25A	8	UBM-25AJ	8	UBM-25OP	6	25	+11 -1	40	-11	58	0	44.1	0	1.85	37.5	2	16.9	74°	1370	3470
30	UBM-30A	8	UBM-30AJ	8	UBM-30OP	6	30	+11 -1	47	0	68	0 -300	52.1	0 -300	1.85	44.5	2	21.1	80°	2100	5920
40	UBM-40A	8	UBM-40AJ	8	UBM-40OP	6	40	+13 -2	62	-13	80	0	60.6	0	2.15	59	3	27.8	80°	3820	9250

Note: 1. Both Linear bearing with single side wiper (UBM.....W) and with double side wiper (UBM.....WW) are available.
 2. 1 Kg_f=9.81 N=2.2046 Lbf
 3. The tolerances stated above are valid for the "Standard Closed Type".

2-2 Metric Dimension - Japanese Exclusive

2-2-1 JB Series: Metric Dimension Series Used Most Frequently in Japan

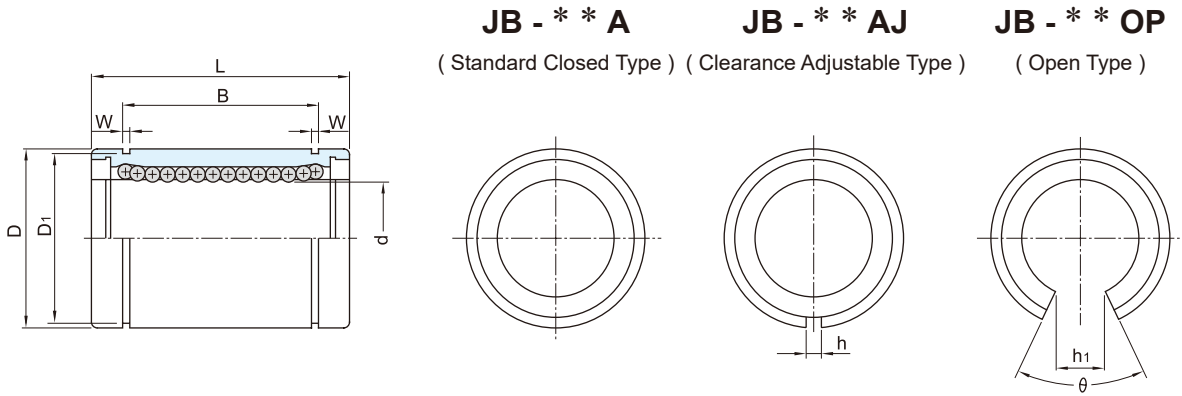

Shaft Diameter d mm	Model						Major Dimensions and Tolerance										Load Capacity					
	Standard Closed Type	Ball Circuit	Clearance Adjustable Type	Ball Circuit	Open Type	Ball Circuit	d		D		L		B		W mm	D1 mm	h mm	h1 mm	θ	Basic Dynamic Load Rating C(N)	Basic Static Load Rating Co(N)	
							mm	Tolerance μ m Precision General	mm	Tolerance μ m	mm	Tolerance μ m	mm	Tolerance μ m								
6	JB-06A	4	-	-	-	-	6		12	0	19		13.5		1.1	11.5	-	-	-	206	265	
8	JB-08A	4	JB-08AJ	4	-	-	8		15	-11	24		17.5		1.1	14.3	1	-	-	274	392	
10	JB-10A	4	JB-10AJ	4	-	-	10	0 -6	0 -9	19		29		22		1.3	18	1	-	-	372	549
12	JB-12A	4	JB-12AJ	4	JB-12OP	3	12		21	0 -13	30	0 -200	23	0 -200	1.3	20	1.5	9.1	80°	412	598	
16	JB-16A	4	JB-16AJ	4	JB-16OP	3	16		28		37		26.5		1.6	27	1.5	11.7	80°	782	1176	
20	JB-20A	5	JB-20AJ	5	JB-20OP	4	20		32		42		30.5		1.6	30.5	1.5	11.6	60°	882	1382	
25	JB-25A	6	JB-25AJ	6	JB-25OP	5	25	0 -7	0 -10	40	0 -16	59		41		1.85	38	2	12.5	60°	980	1568
30	JB-30A	6	JB-30AJ	6	JB-30OP	5	30		45		64		44.5		1.85	43	2.5	16.8	60°	1568	2744	
35	JB-35A	6	JB-35AJ	6	JB-35OP	5	35		52		70	0 -300	49.5	0 -300	2.1	49	2.5	17	50°	1666	3136	
40	JB-40A	6	JB-40AJ	6	JB-40OP	5	40	0 -8	0 -12	60	0 -19	80		60.5		2.1	57	3	22	60°	2156	4018
50	JB-50A	6	JB-50AJ	6	JB-50OP	5	50		80		100		74		2.6	76.5	3	25	50°	3820	7938	

Note: 1. Both Linear bearing with single side wiper (JB.....W) and with double side wiper (JB.....WW) are available.

2. 1 Kgf=9.81 N=2.2046 Lbf

3. The tolerances stated above are valid for the "Standard Closed Type".

2-2-2 JBM Series: Metric Dimension Series Used Most Frequently in Japan

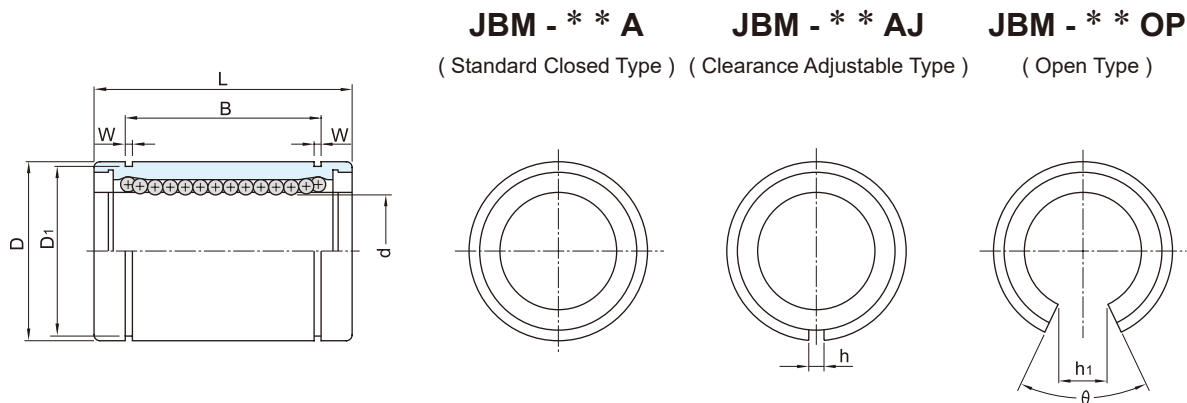

JBM - * * A **JBM - * * AJ** **JBM - * * OP**
(Standard Closed Type) (Clearance Adjustable Type) (Open Type)

Shaft Diameter d mm	Model						Major Dimensions and Tolerance											Load Capacity				
	Standard Closed Type	Ball Circuit	Clearance Adjustable Type	Ball Circuit	Open Type	Ball Circuit	d		D		L		B		W	D1	h	h1	θ	Basic Dynamic Load Rating C(N)	Basic Static Load Rating Co(N)	
							mm	Tolerance μ m	mm	Tolerance μ m	mm	Tolerance μ m	mm	Tolerance μ m								
10	JBM-10A	6	JBM-10AJ	6	-	-	10		19		29		22		1.3	18	1	-	-	451	970	
12	JBM-12A	6	JBM-12AJ	6	JBM-12OP	4	12	0 -6	0 -9	21	0 -13	30	0 -200	23	0 -200	1.3	20	1.5	10.4	100°	500	1049
16	JBM-16A	6	JBM-16AJ	6	JBM-16OP	4	16			28		37		26.5		1.6	27	1.5	13.5	100°	941	2068
20	JBM-20A	6	JBM-20AJ	6	JBM-20OP	4	20			32		42		30.5		1.6	30.5	1.5	16.6	100°	1049	2421
25	JBM-25A	8	JBM-25AJ	8	JBM-25OP	6	25	0 -7	0 -10	40	0 -16	59	0 -300	41	0 -300	1.85	38	2	17.9	80°	1176	2754
30	JBM-30A	8	JBM-30AJ	8	JBM-30OP	6	30			45		64		44.5		1.85	43	2.5	21	80°	1882	4822
40	JBM-40A	8	JBM-40AJ	8	JBM-40OP	6	40	0 -8	0 -12	60	0 -19	80	0 -300	60.5	0 -300	2.1	57	3	27.8	80°	2587	7056

- Note:** 1. Both Linear bearing with single side wiper (JBM.....W) and with double side wiper (JBM.....WW) are available.
 2. 1 Kgf=9.81 N=2.2046 Lbf
 3. The tolerances stated above are valid for the "Standard Closed Type".

2-2-3 JBL Series: Metric Dimension Series Used Most Frequently in Japan

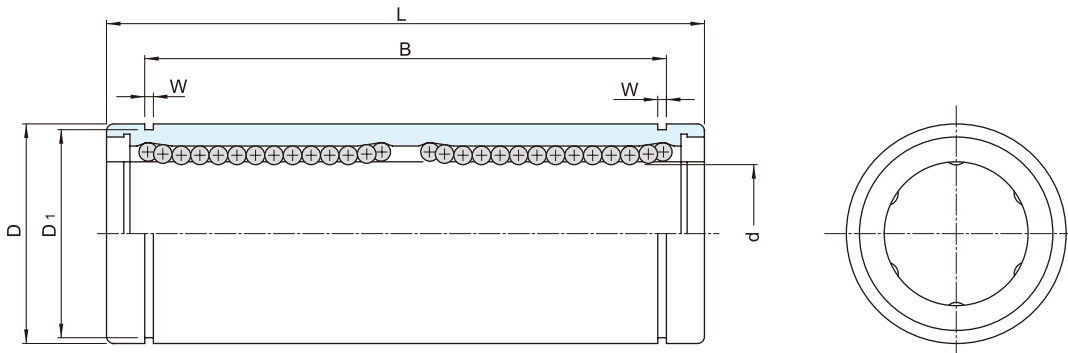

Shaft Diameter d mm	Model JBL Type	Major Dimensions and Tolerance								Load Capacity			
		d mm	Tolerance μm	D mm	Tolerance μm	L mm	Tolerance μm	B mm	Tolerance μm	W mm	D1 mm	Basic Dynamic Load Rating C(N)	Basic Static Load Rating Co(N)
8	JBL-08A	8	0 -9	15	0 -11	45	0 -200	35	0 -200	1.1	14.3	441	804
10	JBL-10A	10		19	0 -13	55		44		1.3	18	608	1127
12	JBL-12A	12		21		57		46		1.3	20	823	1588
16	JBL-16A	16		28		70		53		1.6	27	1245	2352
20	JBL-20A	20	0 -10	32	0 -16	80	0 -300	61	0 -300	1.6	30.5	1401	2764
25	JBL-25A	25		40		112		82		1.85	38	1558	3136
30	JBL-30A	30		45		123		89		1.85	43	2450	5488
35	JBL-35A	35		52		135		99		2.1	49	2646	6272
40	JBL-40A	40	0 -12	60	0 -19	151	121	2.1	57	3479	8232		

Note: 1. Both Linear bearing with single side wiper (JBL.....W) and with double side wiper (JBL.....WW) are available.
2. 1 Kgf=9.81 N=2.2046 Lbf

2-2-4 JBF&JBK Series: Metric Dimension Series Used Most Frequently in Japan

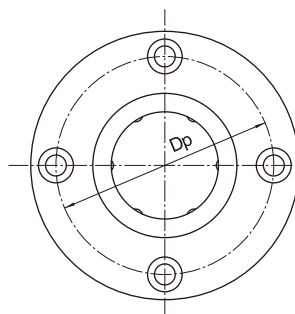
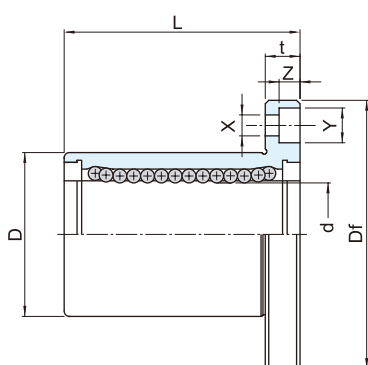

JBF TYPE

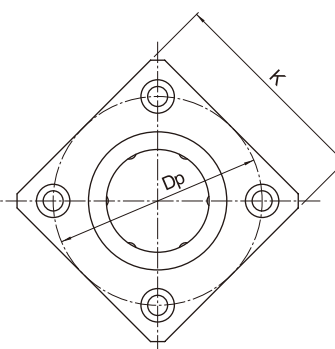

JBK TYPE

Shaft Diameter d mm	Model		Major Dimensions and Tolerance													Load Capacity			
	JBF Type	JBK Type	d mm	d Tolerance μm	D mm	D Tolerance μm	L mm	L Tolerance μm	Df mm	K mm	t mm	Dp mm	X mm	Y mm	Z mm	Concentricity μm	Perpendicularity μm	Basic Dynamic Load Rating C(N)	Basic Static Load Rating Co(N)
8	JBF-08A	JBK-08A	8	0 -9	15	0 -11	24	±300	32	25	5	24	3.5	6	3.1	12	12	274	392
10	JBF-10A	JBK-10A	10		19	0 -13	29		0 -200	40	30	6	29	4.5	7.5			4.1	372
12	JBF-12A	JBK-12A	12		21		30	42		32	6	32	4.5	7.5	4.4			412	598
16	JBF-16A	JBK-16A	16		28		37	48		37	6	38	4.5	7.5	4.1			782	1176
20	JBF-20A	JBK-20A	20	0 -10	32	0 -16	42	0 -300	54	42	8	43	5.5	9	5.1	15	15	882	1382
25	JBF-25A	JBK-25A	25		40		59		62	50	8	51	5.5	9	5.1			980	1568
30	JBF-30A	JBK-30A	30		45		64		74	58	10	60	6.6	11	6.1			1568	2744
35	JBF-35A	JBK-35A	35		52		70		82	64	10	67	6.6	11	6.1			1666	3136
40	JBF-40A	JBK-40A	40	0 -12	60	0 -19	80	0 -300	96	75	13	78	9	14	8.1	20	20	2156	4018

Note: 1. Both Linear bearing with single side wiper (JBF/JBK.....W) and with double side wiper (JBF/JBK.....WW) are available.
2. 1 Kgf=9.81 N=2.2046 Lbf

2-2-5 JBFL&JBKL Series: Metric Dimension Series Used Most Frequently in Japan

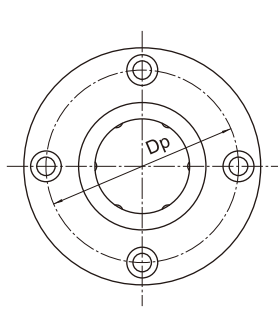
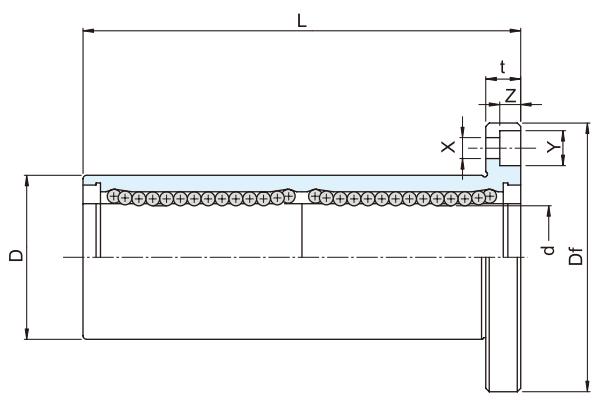

JBFL TYPE

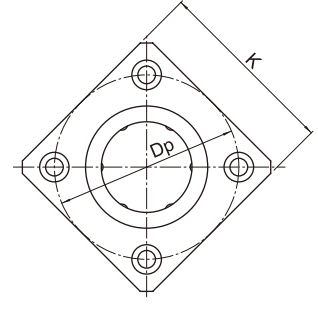

JBKL TYPE

Shaft Diameter d mm	Model		Major Dimensions and Tolerance													Load Capacity			
	JBFL Type	JBKL Type	d mm	Tolerance μm	D mm	Tolerance μm	L mm	Tolerance μm	Df mm	K mm	t mm	Dp mm	X mm	Y mm	Z mm	Concentricity μm	Perpendicularity μm	Basic Dynamic Load Rating C(d)	Basic Static Load Rating Co(d)
8	JBFL-08A	JBKL-08A	8	0 -9	15	0 -11	45	±300	32	25	5	24	3.5	6	3.1	12	12	441	804
10	JBFL-10A	JBKL-10A	10		19	0 -13	55		0 -200	40	30	6	29	4.5	7.5			4.1	608
12	JBFL-12A	JBKL-12A	12		21		57	42		32	6	32	4.5	7.5	4.4			823	1588
16	JBFL-16A	JBKL-16A	16		28		70	48		37	6	38	4.5	7.5	4.1			1245	2352
20	JBFL-20A	JBKL-20A	20	0 -10	32	0 -16	80	0 -300	54	42	8	43	5.5	9	5.1	15	15	1401	2764
25	JBFL-25A	JBKL-25A	25		40		112		62	50	8	51	5.5	9	5.1			1558	3136
30	JBFL-30A	JBKL-30A	30		45		123		74	58	10	60	6.6	11	6.1			2450	5488
35	JBFL-35A	JBKL-35A	35	0 -12	52	0 -19	135		0 -300	82	64	10	67	6.6	11	6.1	20	20	2646
40	JBFL-40A	JBKL-40A	40		60		151	96		75	13	78	9	14	8.1	3479			8232

Note: 1. Both Linear bearing with single side wiper (JBFL/JBKL.....W) and with double side wiper (JBF/JBK.....WW) are available.
2. 1 Kgf=9.81 N=2.2046 Lbf

Linear Bearing Technical Information

Publication Date : September 1998, first edition

Print Date : April 2014, 10th edition

1. HIWIN is a registered trademark of HIWIN Technologies Corp. For your protection, avoid buying counterfeit products from unknown sources.
 2. Actual products may differ from specifications and photos provided in this catalog. These differences may be the result of various factors including product improvements.
 3. HIWIN website for patented product directory: http://www.hiwin.tw/Products/Products_patents.aspx
 4. HIWIN will not sell or export products or processes restricted under the "Foreign Trade Act" or related regulations. Export of restricted products should be approved by proper authorities in accordance with relevant laws and shall not be used to manufacture or develop nuclear, biochemical, missiles or other weapons.
-



Subsidiaries / Research Center

HIWIN GmbH

OFFENBURG, GERMANY
www.hiwin.de
www.hiwin.eu
info@hiwin.de

HIWIN Schweiz GmbH

JONA, SWITZERLAND
www.hiwin.ch
info@hiwin.ch

HIWIN KOREA

SUWON · CHANGWON, KOREA
www.hiwin.kr
info@hiwin.kr

HIWIN JAPAN

KOBE · TOKYO · NAGOYA · NAGANO ·
TOHOKU · SHIZUOKA · HOKURIKU ·
HIROSHIMA · FUKUOKA · KUMAMOTO,
JAPAN
www.hiwin.co.jp
info@hiwin.co.jp

HIWIN s.r.o.

BRNO, CZECH REPUBLIC
www.hiwin.cz
info@hiwin.cz

HIWIN CHINA

SUZHOU, CHINA
www.hiwin.cn
info@hiwin.cn

HIWIN USA

CHICAGO, U.S.A.
www.hiwin.com
info@hiwin.com

HIWIN SINGAPORE

SINGAPORE
www.hiwin.sg
info@hiwin.sg

Mega-Fabs Motion Systems, Ltd.

HAIFA, ISRAEL
www.mega-fabs.com
info@mega-fabs.com

HIWIN Srl

BRUGHERIO, ITALY
www.hiwin.it
info@hiwin.it

HIWIN TECHNOLOGIES CORP.

No. 7, Jingke Road,
Taichung Precision Machinery Park,
Taichung 40852, Taiwan
Tel: +886-4-23594510
Fax: +886-4-23594420
www.hiwin.tw
business@hiwin.tw